



VAASAN AMMATTIKORKEAKOULU
VASA YRKESHÖGSKOLA
UNIVERSITY OF APPLIED SCIENCES

Alexander Juustovaara

RESEARCH OF MODULAR ASSEMBLY METHODS IN NX 8.0

Technology and Communication
2015

ABSTRACT

Author	Alexander Juustovaara
Title	Research of Modular Assembly Methods in NX 8.0
Year	2015
Language	English
Pages	43+3
Name of Supervisor	Juha Hantula

ABB Motors and Generators business unit received a new 3D design program; Siemens NX, in 2008 and took it as main design software in 2010. Since then the assemblies made in the NX were not following any rules thus editing of these assemblies was time-consuming and challenging depending on the designer.

The thesis about a similar topic was made by Sami Risku for ABB, in 2010, but results were not used. The main objective of this thesis was to research further different assembly design approaches and pick the most appropriate method to implement as one of the global rules of 3D assembly for ABB. The result needs to be easy to use by both: basic and advanced NX users. The maintenance of the assembly cannot be time consuming.

Three of the most potential assembly methods were researched deeper and evaluated. Since neither of the methods was perfect for the current case, the best was still chosen by comparing the advantages and disadvantages of the methods as well as by asking for feedback from designers.

VAASAN AMMATTIKORKEAKOULU
Kone- ja tuotantotekniikan koulutusohjelma

TIIVISTELMÄ

Tekijä	Alexander Juustovaara
Opinnäytetyön nimi	Modulaaristen kokoonpanomenetelmien tutkimustyö NX 8.0:ssa
Vuosi	2015
Kieli	Englanti
Sivumäärä	43+3
Ohjaaja	Juha Hantula

Vuonna 2008 ABB Oy, Motor and Generators – yksikkö on saanut käyttöönsä uuden suunnitteluohjelmiston, Siemens NX, ja vuonna 2010 otti sen pääsuunnittelutyökaluksi. Siitä lähtien NX:ssä tehdyt kokoonpanot eivät ole seuranneet minkäänlaisia sääntöjä ja näin niiden muokkaaminen on ollut aikaa vievää ja haasteellista suunnittelijasta riippuen.

Vuonna 2010 Sami Risku oli kirjoittanut ABB:lle opinnäytetyönsä samasta aiheesta, mutta työn tuloksia ei ole otettu käyttöön. Tämän tutkimustyön tavoitteena oli tutkia lisää erilaisia kokoonpanomenetelmiä ja valita niistä aiheeseen sopivin. Menetelmä otetaan pohjaksi ABB:n globaaliin 3D – kokoonpanosääntöihin. Kokoonpanomenetelmän on oltava helppokäyttöinen sekä NX:n perus- että edistyneimmille käyttäjille ja sen ylläpitämiseen ei saa mennä liian kauan aikaa.

Kolme potentiaalisinta kokoonpanomenetelmää oli tutkittu tarkemmin ja arvioitu. Koska mikään menetelmä ei ollut tilanteeseen täydellinen, paras niistä on kuitenkin valittu sekä vertaamalla menetelmien hyviä ja huonoja puolia että suunnittelijoiden palautteen perusteella.

TABLE OF CONTENTS

ABSTRACT

TIIVISTELMÄ

1	PROBLEM DEFINITION AND INTRODUCTION.....	9
1.1	About ABB	9
2	ELECTRIC MOTOR.....	11
2.1	Design Process of an Electric Motor in ABB	11
2.2	Structure of an Electric Motor	12
3	3D MODELING.....	14
3.1	Modeling Process in General	14
3.2	Types of Assembly Design Approaches	14
3.2.1	Bottom-Up	14
3.2.2	Top-Down	15
3.2.3	Middle-Out.....	16
4	SOFTWARE.....	17
4.1	I-DEAS	17
4.2	Siemens NX	18
4.3	Teamcenter.....	19
5	RESEARCH	22
5.1	Modules.....	23
5.1.1	Building Modules.....	24
5.2	Currently Used Assembly Method.....	26
5.3	Arrangements	26
5.4	Method 1: Assembly with Skeleton as a Separate Sub-assembly.....	27
5.4.1	Skeleton.....	28
5.4.2	Replacement of a Module	30
5.4.3	Evaluation	30
5.5	Method 2: Assembly with Sketch as Skeleton.....	31
5.5.1	Skeleton.....	32
5.5.2	Replacement of a Module	33
5.5.3	Evaluation	34

5.6	Method 3: Assembly without Skeleton.....	34
5.6.1	Replacement of a Module	35
5.6.2	Evaluation	35
6	RESULTS.....	36
6.1	Software Challenges While Researching.....	37
6.1.1	PLMXML Error	37
6.1.2	Licenses.....	38
7	OTHER POSSIBILITIES	39
7.1	Teamcenter Variants	39
7.2	Attributes and Expression Templates	40
7.3	Product Interface.....	40
7.4	Intelligent Assembly	41
8	SUMMARY	42

REFERENCES

LIST OF ABBREVIATIONS

2D	Two dimensional
3D	Three dimensional
ABB	ASEA and Brown Boveri
BU	Business Unit
BOM	Bill of Material
CAD	Computer Aided Design
CAE	Computer Aided Engineering
CAM	Computer Aided Manufacturing
CSYS	Coordinate System
D-end	Drive end. The shaft comes out from the frame in D-end and motor can be connected to drive the selected application
FEM	Finite Element Method
I-DEAS	Integrated Design Engineering and Analysis Software - CAD program developed by SDRC and later acquired by Siemens PLM Software
ID	Identification
M&G	Motors and Generators
N-end	Non-drive end. Opposite of D-end, the shaft does not come out of the frame in N-end.
NX	Siemens NX, CAD program
PDM	Product Data Management
PLM	Product Life Cycle Management
R&D	Research and Development
TC	Teamcenter

LIST OF FIGURES

Figure 1. Process performance cast iron motor, frame size 315 /3/	13
Figure 2. Bottom-Up design process.	15
Figure 3. Top-Down design process.	16
Figure 4. Teamcenter environment /10/.	20
Figure 5. Example of D-Bearing module structure in NX.	23
Figure 6. Orientation of a motor to the default coordinate system in NX	25
Figure 7. Example of connection faces of stator frame and end shield.	25
Figure 8. Arrangement specific Distance –constraints.	26
Figure 9. Editing of Arrangement specific constraints.	27
Figure 10. Switching between Arrangements.	27
Figure 11. Assembly chart with skeleton as separate part.	28
Figure 12. Skeleton sub-assembly structure.	29
Figure 13. Skeleton sub-assembly constraints.	29
Figure 14. Skeleton 3D-view.	30
Figure 15. Assembly chart with skeleton as a sketch.	32
Figure 16. Skeleton as a sketch.	33
Figure 17. Controlling skeleton sketch with user expressions.	33
Figure 18. Assembly chart without skeleton.	34
Figure 19. PLMXML Error on save.	38
Figure 20. Variants default interface in Teamcenter.	39
Figure 21. Product Interface.	41

APPENDIX LIST

Appendices contents confidential information and are removed from the public version.

APPENDIX 1. Methods comparison

APPENDIX 2. Q&A SWEMOT

APPENDIX 3. Q&A CNMOT

1 PROBLEM DEFINITION AND INTRODUCTION

ABB Motors & Generators have been using I-DEAS 3D design program since 1997 and in 2008 M&G received a new program, Siemens NX. As both programs have different design approaches and completely different interface, designers using NX needed their own instructions and rules. Since NX does not have a ready- to- use way of creating modular assemblies, Sami Risku finished a thesis named “Research of Assembly Methods in the NX CAD System” in 2010. The objective of his thesis was to research and decide the best way to create assemblies in NX. The outcome suggested the similar way as in I-DEAS by using a separate skeleton part file which is controlled by arrangements. For some reason, the instructions were not taken into use and designers are still creating assemblies without any rules. Since more ABB R&D sites are starting to use Siemens NX as their main 3D design software, it is important to create common instruction. This way designers’ co-operation between sites becomes more effective as the result of less work needed to correct parts and assemblies.

The main objective of this thesis was to research further different assembly design approaches and pick the most appropriate method to implement as one of the global rules of 3D assembly for ABB. The result needs to be easy to use by basic NX users and easy to maintain. Moreover, the chances of somebody to accidentally breaking the system behind the modular assembly has to be decreased to minimum.

1.1 About ABB

ABB is the global leader in power and automation technologies. It is the largest supplier of industrial motors and drives; it provides the most generators to the wind industry and it is the largest supplier of power grids in the world. ABB is divided into five divisions in relation to the customers they serve: Power Products, Power Systems, Discrete Automation and Motion, Low Voltage Products and Process Automation. The company operates in approximately 100 countries and employs around 145 000 people, 5 400 of which in Finland. ABB became of what it represents nowadays by acquisitions and mergers. Primarily ABB is an outcome

of merging two well-known companies: ASEA of Sweden and Switzerland's Brown Boveri in 1988 /15/.

ABB have three factory sites in Finland: Helsinki, Vaasa and Porvoo. All of the divisions are represented with an addition of Domestic Sales and Service.

ABB Oy Motors & Generators unit is a part of Discrete Automation and Motion division and represented in Helsinki and Vaasa. High voltage motors, diesel generators and permanent magnet motors are manufactured in Helsinki, while Vaasa has global responsibility for low voltage motors for explosive atmospheres /1/.

ABB is one of the biggest industrial employers with a turnover of about 2.3 billion euros and Research & Development investment about 193 million euros a year.

2 ELECTRIC MOTOR

An electric motor is an old invention but the development of it was quite slow. The structure of the motor is simple, so the development has concentrated on improving the efficiency, durability and optimizing mechanical materials. The electric motor converts electric energy into mechanical energy. Electricity led into the stator creates a magnetic field and by changing polarity, the rotor is rotating.

2.1 Design Process of an Electric Motor in ABB

Creating an electric motor is not just about creating drawings and manufacturing parts but it is a long process which starts from the idea and ends at the evaluation of feedback of users. Usually, unless it is a completely new product, and even then, the process is mostly about modifying and improving the parts of the old motor to meet new criteria.

The process starts from the need. The need can be a customer's need for a new product, need for a profit, need for a new product because of new regulations or all of these together. Because of these needs new projects are made. The progress of projects is tracked through "gates" where each gate has its own list of requirements the project needs to fulfill to pass the gates. The number of gates depends on a project scale and may vary from 3 to 7.

The first stage is the beginning of a new project with an idea or a need which comes from the BU Manager or Sales. When the idea is more or less defined, the product manager transfers the idea to the R&D manager. Immediately after that the timetable of a project is created and the review of required resources, which are dependable on the project scope and the due date, is made. The main part of resources is human resources, so the suitable leaders for the project are chosen. The next step would be to define if the existent parts from other projects can be used as they are or if they can be modified to suit the specifications of a project. Depending on the availability of modifiable parts and 3D program they are made with, the rest of the team is picked. At this stage the estimated budget and timetable are to be made. Also, to ease the load of project manager, responsible

persons for different areas of the project, i.e. mechanical design, electrical design, are picked. When mechanical and marketing requirement specifications have been fulfilled and the design is ready, depending on the project scale, the prototype building and testing begins. Meanwhile, the rest of the documentation, design and marketing material must be completed. After the documentation is ready, with testing gone successfully and quality control passed, a product is released for sales. From this point on the product maintenance team is responsible for the product. After about half a year another gate is held, when the product related feedback is evaluated.

2.2 Structure of an Electric Motor

The electric motor can consist of hundreds of parts. The core elements are the stator with windings and the rotor with the shaft but also stator frame, end shields, bearings, terminal box and fan with cover are important parts. Figure 1 displays an exploded view of the motor and most of these parts are replaceable during the lifetime of the motor.

The parts are organized into groups called modules. The modules are, to some extent, interchangeable sub-assemblies and can consist of dozen of parts. Some modules and parts have a similar design but located in the opposite ends of the motor. These parts or modules are thus marked D-end for the drive end and N-end for the non-drive end. In some cases the motor has two drive ends.

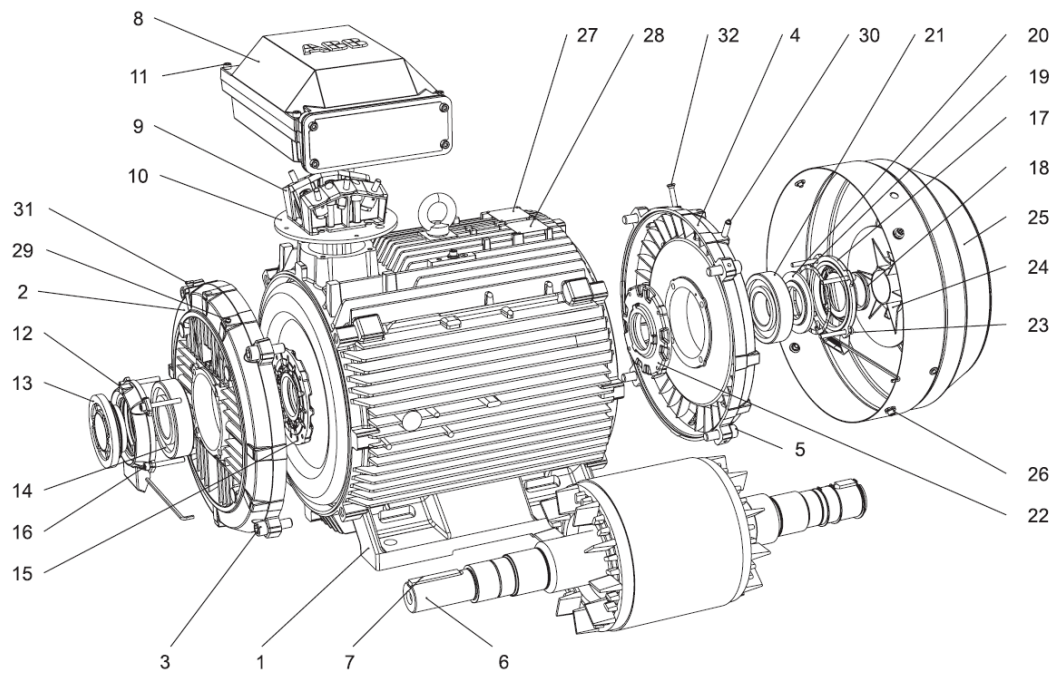

- | | | |
|----------------------------------|--|-----------------------------|
| 1 Stator frame | 13 Valve disc with labyrinth seal, D-end; standard in 2-pole motors, V-ring in 4-8 pole motors | 23 Screws for bearing cover |
| 2 End shield, D-end | 14 Bearing, D-end | 24 Fan |
| 3 Screws for end shield, D-end | 15 Inner bearing cover, D-end | 25 Fan cover |
| 4 End shield, N-end | 16 Screws for bearing cover | 26 Screws for fan cover |
| 5 Screws for end shield, N-end | 17 Outer bearing cover, N-end | 27 Rating plate |
| 6 Rotor with shaft | 18 Seal, N-end | 28 Lubrication plate |
| 7 Key, D-end | 19 Wave spring | 29 Grease nipple, D-end |
| 8 Terminal box | 20 Valve disc, N-end | 30 Grease nipple, N-end |
| 9 Terminal board | 21 Bearing, N-end | 31 SPM nipple, D-end |
| 10 Intermediate flange | 22 Inner bearing cover, N-end | 32 SPM nipple, N-end |
| 11 Screws for terminal box cover | | |
| 12 Outer bearing cover, D-end | | |

Figure 1. Process performance cast iron motor, frame size 315 /6/

3 3D MODELING

3D modeling means three-dimensional design of a product. From the point of view of the designer, 3D pieces, parts and assemblies have to be visually correct and they got all the physical and mechanical properties the real product would have.

3.1 Modeling Process in General

Modeling follows always the same route with three main steps. Input data gathering, when the designer receives an idea, sketches or even ready product, and a task. Second step is a preparation phase when the system is customized with the customers' templates and requirements. The last step would be modeling itself: starting with drawing rough sketches based on the input data, followed by creating solid models. After creating the required amount of components, an assembly is made. Necessary 2D drawings are also made from complete parts and assemblies /14/.

3.2 Types of Assembly Design Approaches

Different programs for 3D design have different ways to create an assembly. Despite that there are three main approaches how assemblies are made.

3.2.1 Bottom-Up

The Bottom-Up assembly design method is the most traditional one. It is easy to understand and is used especially by new users. Assemblies are made from parts which are created independently. This method is preferred in large assemblies with complex components and when using parts which are pre-designed.

In the bottom-up method the assembly is created by modeling all of the parts first. After that parts are combined into sub-assemblies which are used to create the final assembly (Figure 2) where all components are placed into the right places and dependencies are made. /5/

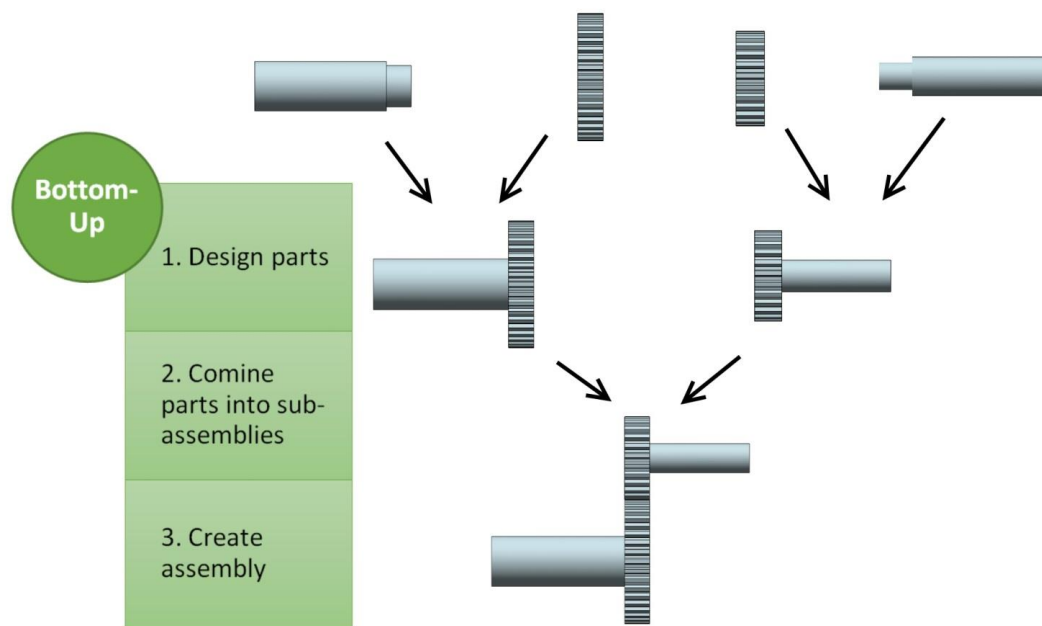

Figure 2. Bottom-Up design process.

3.2.2 Top-Down

In this approach the main assembly file is created first. Parts and sub-assemblies which are derived from the main assembly are improved to be more detailed (Figure 3). Parts are also linked to the main assembly so changes there will be reflected to lower levels keeping them updated.

The top-down assembly order resembles a design process. First there is an overall sketch which shows space reservation for the assembly and main sub-assemblies or parts. After that there is a more detailed design of sub-components. Their dimensions become more solid, physical properties are adjusted and structural analysis is performed. /5/

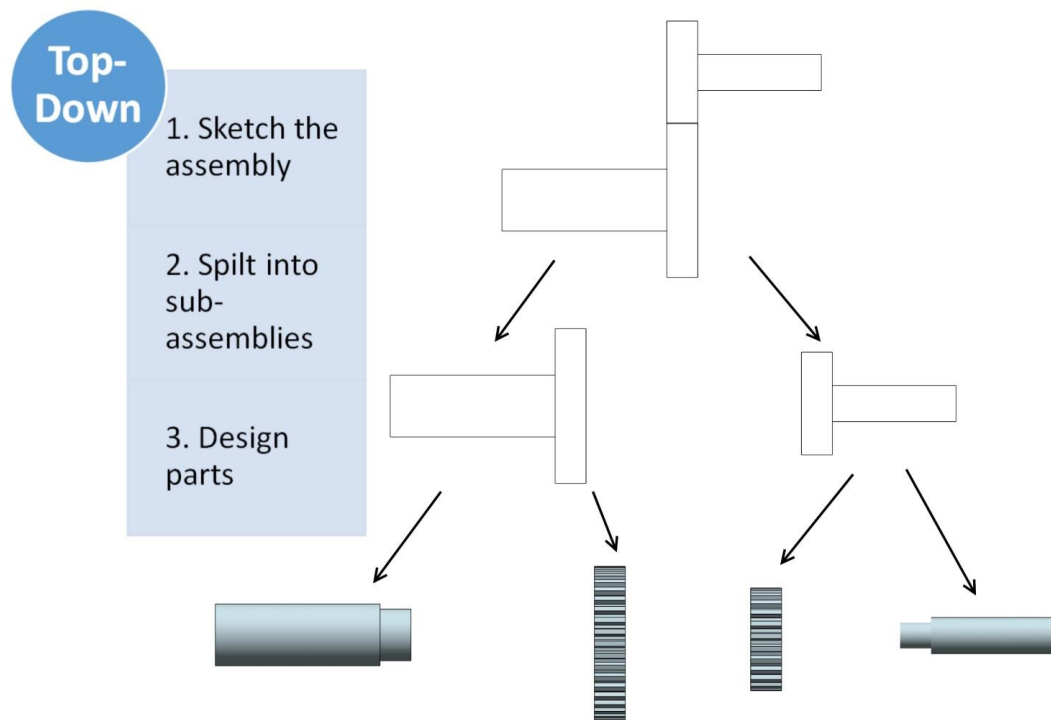

Figure 3. Top-Down design process.

3.2.3 Middle-Out

The mixture of bottom-up and top-down methods is the most common method. While some components are made as individual parts, other might be linked to each other via common features or share the same parameters.

4 SOFTWARE

ABB is using numerous software programs to improve work efficiency and get better results but in this chapter only the programs which are connected to the objective of the thesis are presented.

4.1 I-DEAS

Designed for both general engineering use and most demanding CAE specialists, I-DEAS was originally produced by Structural Dynamics Research Corporation (SDRC) in 1982 to fill a space in growing mechanical computer-aided engineering marketplace. 11 years after that completely re-architected software was presented. I-DEAS “Master Series” was used particularly in automotive industry, where the largest amount of users came from. Other industries are aerospace and defense, electronics and consumer products, industrial equipment and energy and process /1/.

I-DEAS has many functions and they are divided into categories or modules which work as separate work environments. Some of modules of I-DEAS /4/:

- Master Modeler
- Master Drafting
- Master Assembly Set
- Sheet Metal Design
- Harness Design
- Master FEM

In ABB M&G, I-DEAS has been used as the main 3D design program since 1997. Lots of customizations were made towards automation of some design processes and some cooperation actions were improved with Teamcenter. One of the improvements is the modular assembly design method using a skeleton part. This

method was implemented in the early adaptation process of I-DEAS and has been used since then.

Since I-DEAS is already old software the support of which will eventually end in the near future, there is a plan to end the use of I-DEAS and fully switch to Siemens NX in 2015, when the migration of I-DEAS data is scheduled to be finished.

4.2 Siemens NX

Siemens NX software is an integrated product design, engineering and manufacturing solution (CAD/CAE/CAM). Developed in 2002 by UGS Corp, which was acquired by Siemens in 2007, NX is an outcome of merging functionality and capabilities of two other CAD/CAE software programs, Unigraphics and I-DEAS. Siemens PLM automation is actively suggesting old I-DEAS users as well as users of other programs to switch to NX /9/.

NX for design is 3D product design software. It offers a set of functions which will lead the user through the design process: 2D sketching, 3D modeling, assembly design and drafting. Moreover, using and editing parts created with other CAD software is possible with the NX synchronous technology.

NX is virtually divided into three main categories: NX for Design (CAD), Simulation (CAE) and Manufacturing (CAM). All these three are subdivided and represented as applications. The applications form a list of modules NX consists of. Some of the modules are /7/ :

- Modeling – used to create and edit part geometry. Solid body models are created by adding features to the model
- Assemblies – used to create the hierarchical structure of a product by adding components to an assembly
- PMI (Product and Manufacturing Information) – used to create 3D annotations to the model
- Drafting – used to create 2D drawings of the final design
- Manufacturing – used to create NC tool paths

- Design Simulation – used to compute structural deformation and stress on a finite element model

ABB M&G started to test Siemens NX in 2008 by a couple of key users. Since 2010 a larger group of designers started to use NX to create new parts in new development projects. After testing was made, all remaining designers have received basic and advanced training either from an outside company or through inside training sessions. The final transfer to NX is scheduled for 2015; however, it depends on the success and completion of migration process of I-DEAS data.

4.3 Teamcenter

Teamcenter is one of the most widely-used software suite for product lifecycle management (PLM). Original Teamcenter was created in mid 80s by combined technology and components from Control Data, SDRC and UGS. Later on the program became property of EDS PLM Solution which Siemens acquired in 2001 /12/.

Teamcenter PLM can be used to control mechanical, electronics, software and simulation data, as well as documents and bill of materials in single environment (Figure 4). Every application of Teamcenter is supported due to common PLM platform and among other capabilities customer-specified implementations are easy and quick to set up. Teamcenter is designed to speed up development processes, cut release time for products, optimize resources of a company and keep connection with suppliers. Authorized employees are able to quickly access the information which is necessary to perform their tasks /13/.

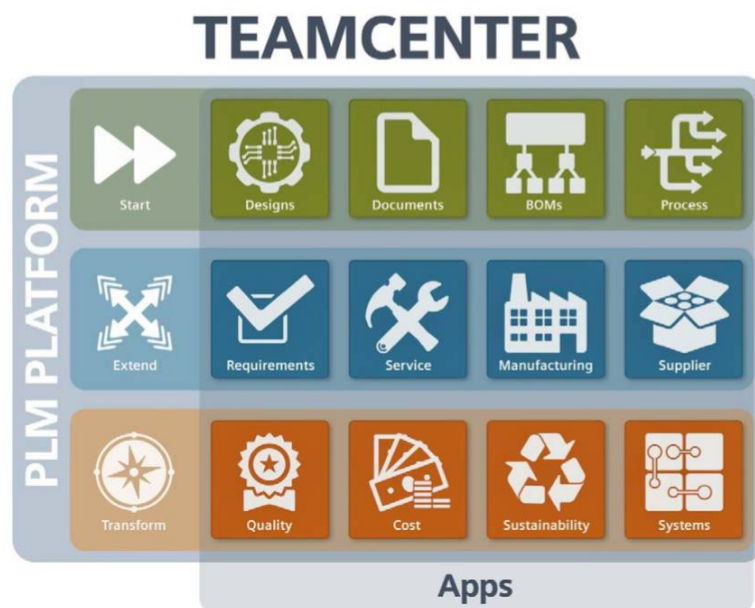

Figure 4. Teamcenter environment /13/.

While Teamcenter is called as PLM software, PLM and PDM (Product Data Management) terms mean about the same. PDM is focused on managing part number and description, documents, product hierarchy and revisions. PLM covers the same things as PDM but also may contain other information, such as marketing, sales and aftersales data. As this thesis concerns only data management, Teamcenter will be approached as PDM software alone.

Among other things Teamcenter allows CAD software integration. CAD integration is helping to keep consistency of drawings and product structure. CAD integration can be one or bi-directional. One-directional integration transfers data from CAD to PDM. In addition to drawing, the data includes attributes, such as name of the designer and date the drawing was made. In bi-directional integration data is transferred also from PDM to CAD. For example, the product structure can be changed in PDM wherefrom changes will reflect to the CAD product structure /10/.

Both NX and I-DEAS are integrated into Teamcenter. While NX is integrated bi-directionally, the I-DEAS integration is one-directional. However, an interface called Elink was made and it makes the I-DEAS integration nearly bi-directional.

For example, BOM data can be changed both from NX and Teamcenter and these changes will reflect to the other program. This is particularly interesting as this concerns the thesis and future visions of improving design workflow.

In ABB M&G Teamcenter has been used since 2008. At the same time integration with NX was made.

5 RESEARCH

The research begun by searching for similar thesis projects which concern modular 3D assembly or assembly in NX in general. Not much of other help was found but Sami Risku's thesis /11/ since the problem is actually quite narrow and has some restrictions. One thing that is limiting is the large number of parts and assemblies that have already been modeled using NX and many of these parts are oriented in different directions. Another restriction is custom dimensions. Vaasa M&G produces around 200 motors daily but the average order size is just around two motors per customer which means that lots of customized motors are being designed and manufactured for the specific customer's needs. The number of motors with different size and equipment range is huge and all the dimensions cannot be standardized or parameterized. This limits the use of any drop-down lists or creating of only one skeleton file.

Since ABB is a global company and Teamcenter is used by a large group of people, changes to it should be tested first in a safer environment. The solution for it was another installation of Teamcenter for development purposes and I was given an access to it. That way I had free hands in creating and testing assemblies without worrying that my action would affect real development or production.

The practical part begun with testing different ideas as well as reading about different kind of 3D assembly approaches. Regardless of the fact that assembly method with the skeleton was researched before, only a few people had some memories of it. The decision was to check it first because it is relatively famous method and I was a bit familiar with it. Later on I received an idea about using the main assembly sketches as a skeleton, which was very similar to the first case but seemed way too complicated. The third method was tested based on basic mating of parts but using CSYSs.

Neither of the methods can be based strictly on the top-down or bottom-up approaches. While top-down would be too stiff for a changes, bottom-up, on the other hand should be also avoided as it does not improve assembly experience. Two of the following methods resemble top-down design approach and the last

one resembles bottom-up, however they might be all classified as middle-out methods. All the parts are modeled as stand-alone objects and assemblies are made using ordinary constraints but with some kind of a skeleton in the middle and additional help of the modules.

The creation of modules as they are has to be also standardized, so they can be interchangeable. Since the modules do not require modifications regardless of what assembly method they are used in, the next topic will be about modules. Moreover, in Chapter 7 there are more views on other methods I considered as possible solutions.

5.1 Modules

Since the solution is to be about the modular assembly, every module of the same group has to be created using the same rules. In this way modules will be interchangeable and the assembly system is easier to modify.

Modules are smaller parts of bigger system or sub-assemblies of the higher assembly (Figure 5). In M&G modules were used since late nineties in older ERP software and later they were implemented into the CAD system. Modules were taken into use because they make the handling of big assemblies easier and more organized. Since the motor can consist of hundreds of parts, dividing them into sub-assemblies and spreading them among designers speeds up the design process and parts connectivity.

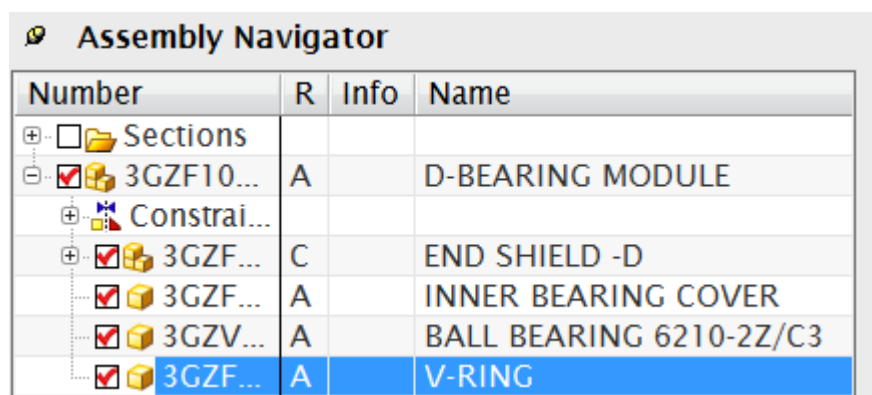

Number	R	Info	Name
Sections			
3GZF10...	A		D-BEARING MODULE
Constrai...			
3GZF...	C		END SHIELD -D
3GZF...	A		INNER BEARING COVER
3GZV...	A		BALL BEARING 6210-2Z/C3
3GZF...	A		V-RING

Figure 5. Example of D-Bearing module structure in NX.

Currently Teamcenter has two kinds of modules: the structure of the motor for official BOM and I-DEAS/NX BOM items where available 3D parts were assembled for assembly instructions. The Teamcenter BOM items include all the items the final product is made from. They are used for information purpose for sales and purchases. 3D BOM, on the other hand, includes 3D models of nearly all or all of the parts motor is made from. Although TC BOM consist of the items with right item IDs, some of them either do not have 3D model at all or models are made using different 3D programs. 3D BOM on the contrary have all the 3D models but their ID codes might be different from the right ones due to some early problems with locked items and transferring an item from I-DEAS to NX.

5.1.1 Building Modules

Modules can be built either from a scratch or by revising Teamcenter BOM structure and adding a 3D model file to it. Building a module from an existing TC BOM requires creating new revision and importing an NX template model file which is used in all NX items being made in M&G. Building a module from a scratch is also easy: create new item and add module parts to it.

Although the beginning is different, the end is the same. All modules should be assembled keeping in mind their default position and orientation in the main assembly. The general rule for modules is that parts they consist of must be oriented and placed right according to default CSYS. The location of the default CSYS is in the origin, where X, Y and Z are equal to zero and views are NX default views, as following: XZ is front, YZ is right and XY is top view (Figure 6).

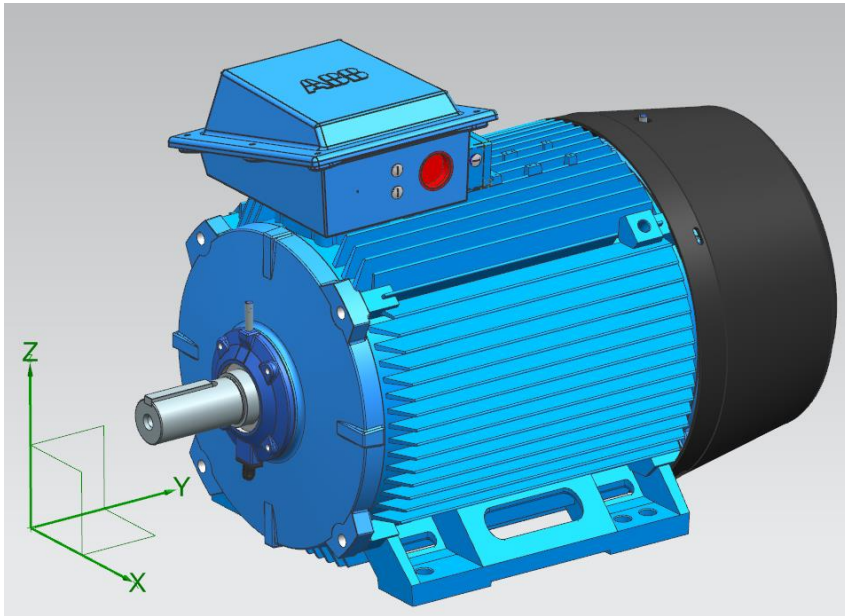

Figure 6. Orientation of a motor to the default coordinate system in NX

However, since modules are different types, instructions should be made for each of them about how the parts are to be placed and what the connection faces for each module are (Figure 7).

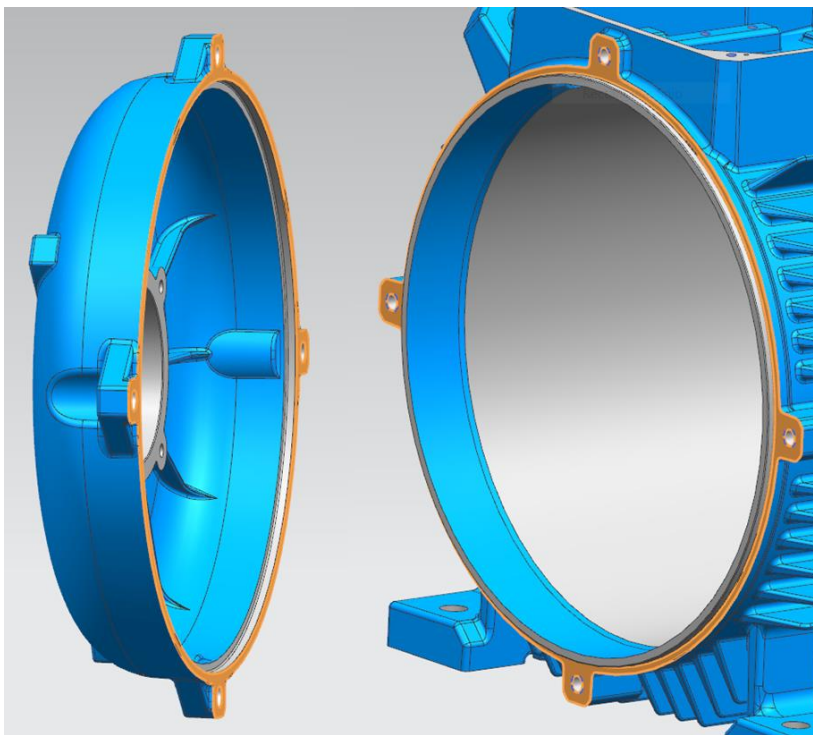

Figure 7. Example of connection faces of stator frame and end shield.

5.2 Currently Used Assembly Method

Currently most of the assemblies are constrained by the geometry and consists only of parts instead of modules or other kind of sub-assemblies. Some of assemblies, on the other hand, are a mix of sub-assemblies and parts.

5.3 Arrangements

Some of designers used arrangements in their assemblies and I found out it is a powerful tool if it is used right. Assembly Arrangements is a command that allows defining alternative positions for parts or sub-assemblies in the assembly. Arrangements allows the editing of constraints (Figure 8 and Figure 9) and suppressing components, making switching between and creating new assemblies much simpler (Figure 10).

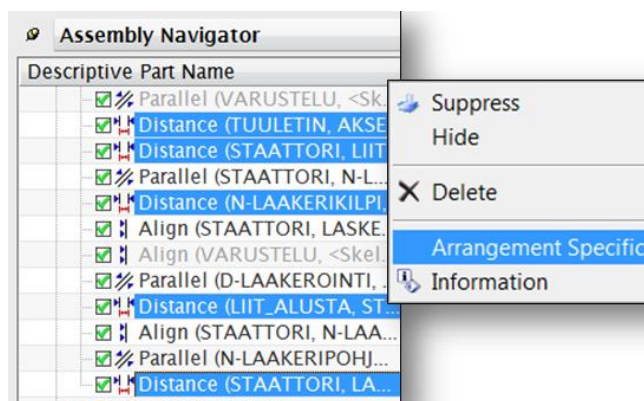

Figure 8. Arrangement specific Distance –constraints.

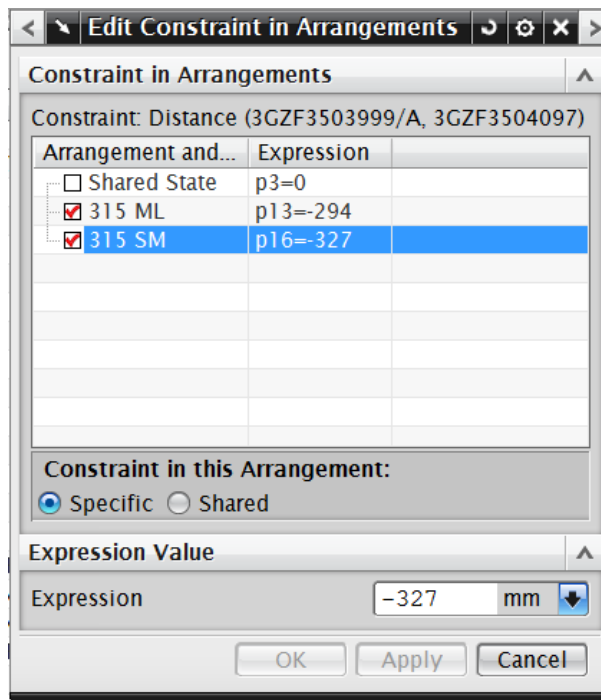

Figure 9. Editing of Arrangement specific constraints.

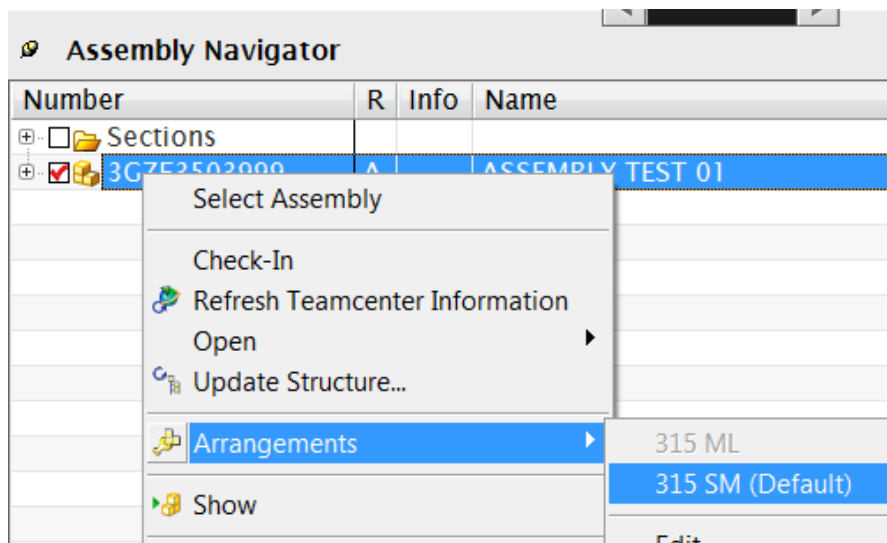

Figure 10. Switching between Arrangements.

5.4 Method 1: Assembly with Skeleton as a Separate Sub-assembly

The skeleton as a separate part file is in use in I-Deas' assemblies and there was an attempt to implement it into NX. This method seemed like a favorite one but the fact it was not taken into use, forces to take it with caution. As seen in Figure

11., the top, or main, assembly part file works only as an assembly and in the beginning consists of nothing but the default CSYS. The first step would be to add a skeleton file suitable for the wanted motor or to add the one which fits the best one and modify it. After the skeleton is added and fixed at the assembly's default CSYS, modules may be added and constrained CSYS to CSYS with the respective skeleton CSYSs. Afterwards the adjustments of skeleton model are made, if needed.

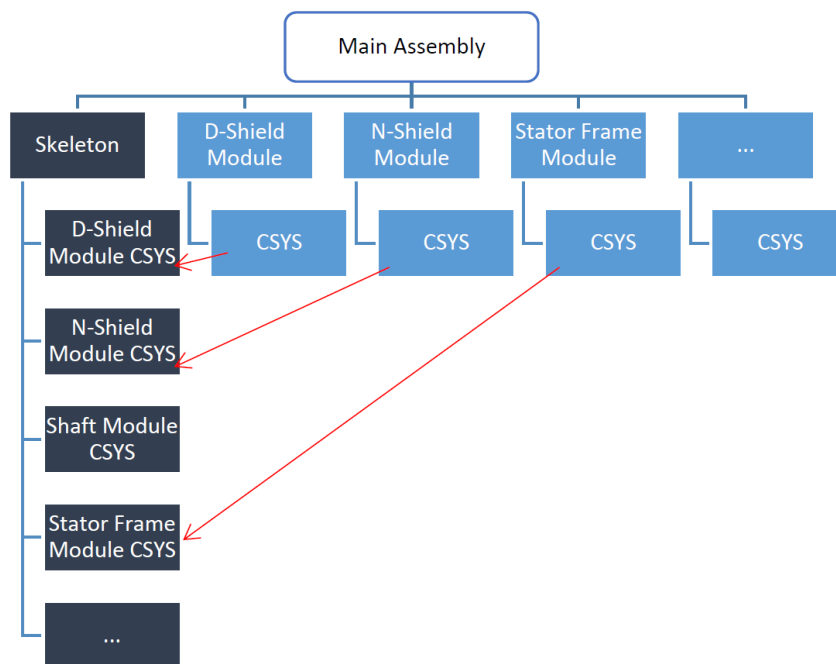

Figure 11. Assembly chart with skeleton as separate part.

5.4.1 Skeleton

The skeleton works as a guiding model. It can consist of shapes and feature outlines, parameters, reference geometry and surfaces. The skeleton can be used in many situations: to align and constraint assembly parts, to link dimensions to sub-assemblies or parts, for space reservation and to determine the path of moving parts /3/.

In this case the skeleton is an assembly of CSYSs which are located in specific places to assist assembling and replacing components. These CSYSs can be moved parametrically through the Arrangements –option. The skeleton consists of

parts named after each module and these parts include nothing but a coordinate system placed in the origin. All of these parts are added to the main skeleton assembly (Figure 12) and placed around the origin with constraints (Figure 13), forming the skeleton of the motor (Figure 14).

Assembly Navigator			
Number	R	Info	Name
Sections			
<input checked="" type="checkbox"/> 3GZF3503963	A		SKELETON
Constraints			
<input checked="" type="checkbox"/> 3GZF3503973	A		STATOR FRAME MODULE COORD
<input checked="" type="checkbox"/> 3GZF3503966	A		STATOR COORD
<input checked="" type="checkbox"/> 3GZF3503967	A		ROTOR COORD
<input checked="" type="checkbox"/> 3GZF3503965	A		N-BEARING MODULE COORD
<input checked="" type="checkbox"/> 3GZF3503970	A		TERMINAL BOX MODULE COORD
<input checked="" type="checkbox"/> 3GZF3503968	A		OUTFIT MODULE COORD
<input checked="" type="checkbox"/> 3GZF3503972	A		D-BEARING MODULE COORD

Figure 12. Skeleton sub-assembly structure.

Constraint Navigator	
Name (Group by Constraints)	
Work Part	
<input checked="" type="checkbox"/>	Align (3GZF3503963/A, D-BEARING MODULE)
<input checked="" type="checkbox"/>	Align (3GZF3503963/A, OUTFIT MODULE)
<input checked="" type="checkbox"/>	Align (3GZF3503963/A, ROTOR)
<input checked="" type="checkbox"/>	Align (3GZF3503963/A, ST FRAME MODULE CSYS)
<input checked="" type="checkbox"/>	Align (3GZF3503963/A, ST FRAME MODULE CSYS)
<input checked="" type="checkbox"/>	Align (3GZF3503963/A, STATOR)
<input checked="" type="checkbox"/>	Align (3GZF3503963/A, TERMINAL BOX MODULE)
<input checked="" type="checkbox"/>	Distance (3GZF3503963/A, D-BEARING MODULE) "Y"
<input checked="" type="checkbox"/>	Distance (3GZF3503963/A, N-BEARING MODULE)
<input checked="" type="checkbox"/>	Distance (3GZF3503963/A, OUTFIT MODULE)
<input checked="" type="checkbox"/>	Distance (3GZF3503963/A, ROTOR)
<input checked="" type="checkbox"/>	Distance (3GZF3503963/A, ST FRAME MODULE CSYS)
<input checked="" type="checkbox"/>	Distance (3GZF3503963/A, STATOR)
<input checked="" type="checkbox"/>	Distance (3GZF3503963/A, TERMINAL BOX MODULE)
<input checked="" type="checkbox"/>	Distance (3GZF3503963/A, TERMINAL BOX MODULE) "Y"
<input checked="" type="checkbox"/>	Distance (3GZF3503963/A, TERMINAL BOX MODULE) "Z"
<input checked="" type="checkbox"/>	Parallel (3GZF3503963/A, D-BEARING MODULE)
<input checked="" type="checkbox"/>	Parallel (3GZF3503963/A, N-BEARING MODULE)
<input checked="" type="checkbox"/>	Parallel (3GZF3503963/A, OUTFIT MODULE)
<input checked="" type="checkbox"/>	Parallel (3GZF3503963/A, ROTOR)
<input checked="" type="checkbox"/>	Parallel (3GZF3503963/A, STATOR)

Figure 13. Skeleton sub-assembly constraints.

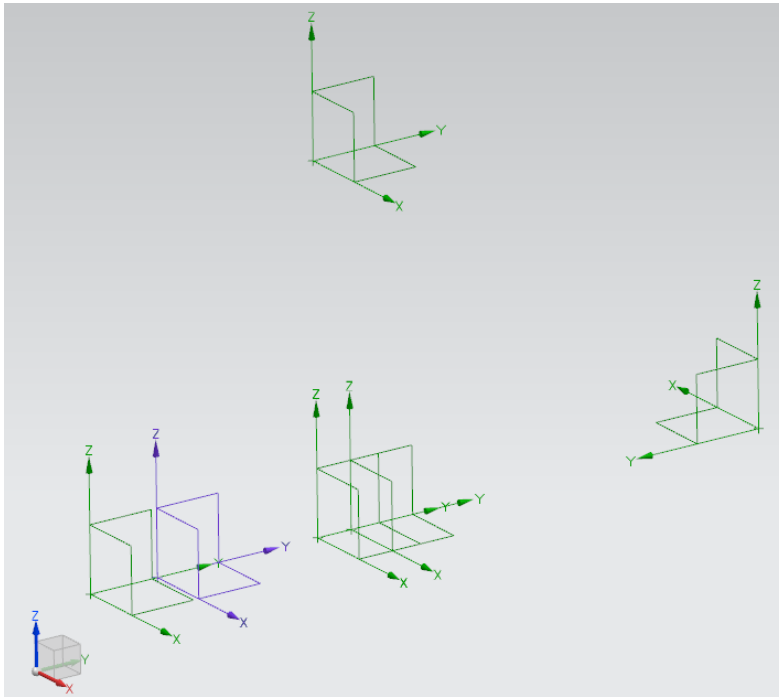

Figure 14. Skeleton 3D-view.

5.4.2 Replacement of a Module

The replacement of modules is easy: Replace –command allows you to choose a module you want to replace and if the module CSYS is oriented in the same way, the new module will jump into the place of an old module. No additional actions are required.

5.4.3 Evaluation

Module replacement itself is very easy if the modules are built in the same way. It is also possible to use Arrangements to control different aspects of the assembly, such as frame length, different mounting options or placement of modules. In this method Arrangements is possible to use for both, suppressing and controlling dimension constraints.

This method has also its disadvantages. To modify the skeleton for the current motor assembly, you will first need to go to the skeleton part and edit values of every related constraint, save the part and check the main assembly to see if the modules snapped to their places and no overlapping is appeared.

Every frame size or even every assembly will need its own skeleton, otherwise changes will be reflected to other assemblies the skeleton is used in. An exception is possible if the skeleton is used for the same sized motors where the parts are changed but the assembly dimensions stay the same. In that case arrangements will work perfectly and will not interfere with other assemblies if the arrangement is changed through the main assembly.

Another challenge is that the separate skeleton file affects BOMs as it will be visible in the NX part navigator and Teamcenter BOM unless it is hidden by using “Reference Only” –option in part properties.

5.5 Method 2: Assembly with Sketch as Skeleton

The structure of this kind of assembly is similar to the assembly with a separate skeleton but instead of the separate skeleton sub-assembly, the sketch, or group of sketches are working as a skeleton (Figure 15). These sketches are integrated into the main assembly and are accessible through the Part Navigator panel.

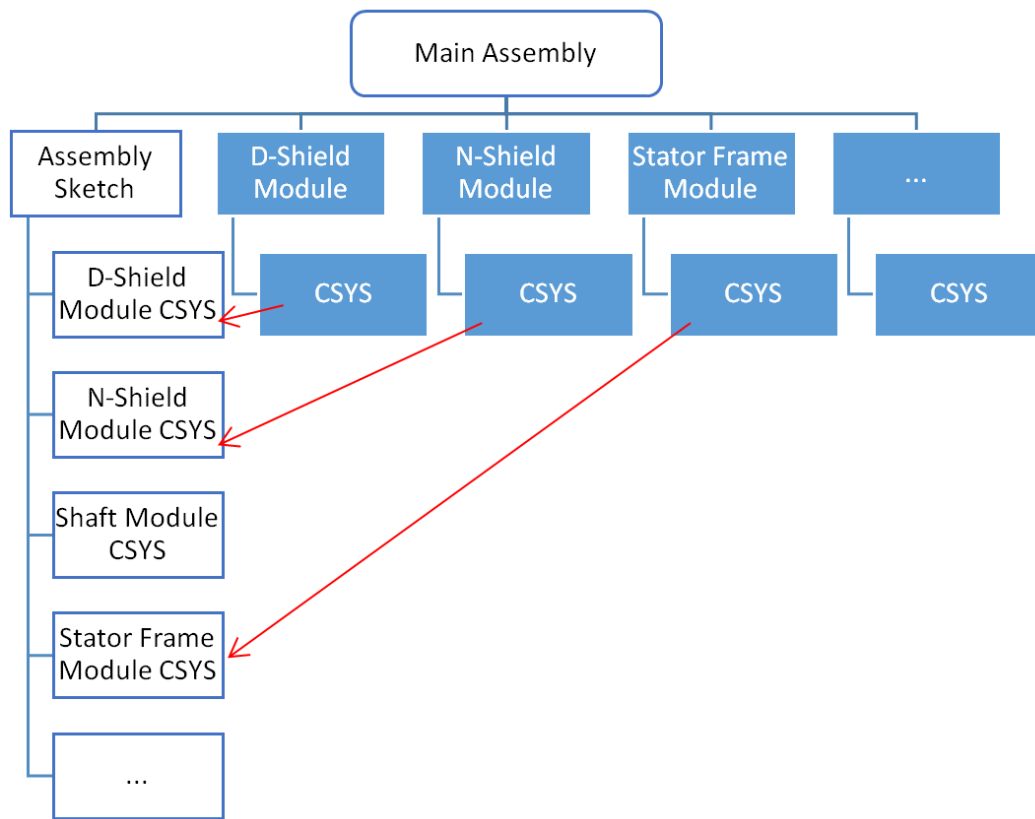

Figure 15. Assembly chart with skeleton as a sketch.

5.5.1 Skeleton

The sketch works as a skeleton where CSYSs locations are defined by points (Figure 16). These points are driven by dimensions which values are modifiable through User Expressions (Figure 17). Coordinate systems are placed at points outside the sketch.

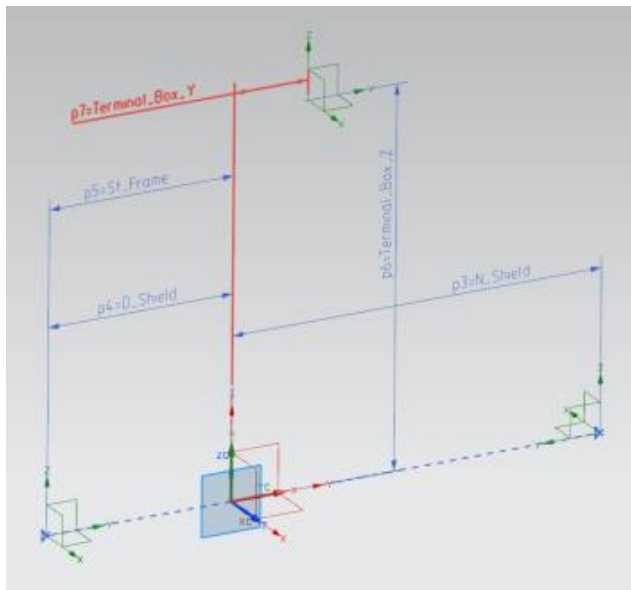

Figure 16. Skeleton as a sketch.

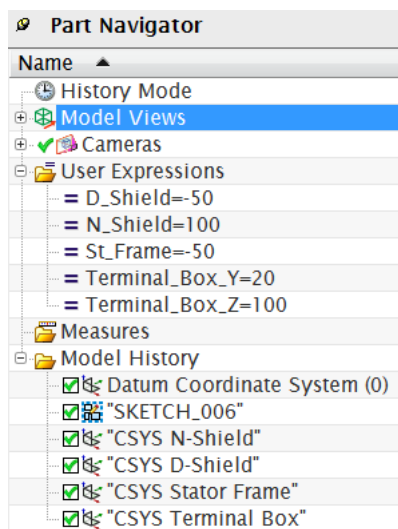

Figure 17. Controlling skeleton sketch with user expressions.

5.5.2 Replacement of a Module

The replacement of modules is as easy as in the previous method. If the replacement module is assembled right, Replace -command will replace the modules with no problems.

5.5.3 Evaluation

Easy module replacement and no external skeleton file are advantages of the method. It is also easier to modify the skeleton since results are visible right away. However, lack of a separate skeleton file means that unless a perfect template file is made, the main assemblies will be recycled/copied for each new motor assembly.

The flexibility of this skeleton is bad: in case you need more than one instance of the same module but with different placement, it will be a very complex setup. Since dimension constraints are driven by User Expressions, Arrangements use would be complicated as well. However, arrangements use for suppression works fine, although it will not be as useful anymore.

5.6 Method 3: Assembly without Skeleton

This method is basically the ordinary bottom-up constraint method but instead of surfaces and edges, CSYSs are being constrained together (Figure 18).

Using Align and Distance constraints CSYSs of modules are constrained to the main assembly CSYS.

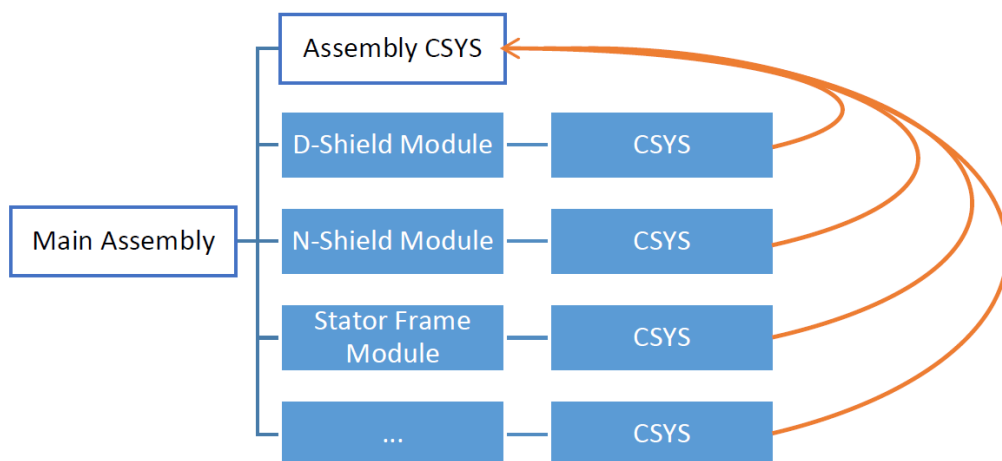

Figure 18. Assembly chart without skeleton.

5.6.1 Replacement of a Module

The replacement of modules with Replace-command is simple and does not need any additional actions.

5.6.2 Evaluation

This method is easy and does not require lots of setups. The method allows the use of Arrangements for both, suppressing modules and controlling distance constraints.

Module replacement is easy but fragile: sometimes, if modules were created using some other templates, constraints might break and that will require some repair actions. Although constraints would be easy to recreate, there might be many arrangements which depend on them and it will take much more time to recreate constraints.

Since there is no skeleton and the main assembly works as a controller, this requires a good template to begin with. Training designers how to use arrangements would be important, so the user will be able to modify other assemblies to suit his own needs.

6 RESULTS

All methods have their advantages and disadvantages. Skeleton methods would be great if assemblies would be more standardized, but since they are not, skeleton building, modifying and maintaining is complicated. The skeleton-free method on other hand does not have such a good structure as others but it is winning at Arrangements and being simpler.

The simplified instruction of all methods and module building were sent to China, Sweden and Spain Motor and Generators designer teams to receive some comments and ideas but the feedback was not very informative. The main reason was that these sites are just taking the NX into use and do not have enough experience to give any valuable information. However, method 3 received more positive feedback since it was closer to what designers are using at the moment. Nevertheless, all the feedback has to be taken into account.

Between two skeleton methods, method 2 is much more complicated to build and maintenance. Although it does not have any extra parts, since the usage is based on User Expressions, effective use of Arrangements is not possible. Method 1 on the other hand is more flexible since the skeleton may be either copied forward to the next assembly or the original template skeleton may be updated to suit more assemblies. So, choosing method 1 to represent skeleton methods is natural. The next step is to decide if the skeleton method will be better than non-skeleton or not.

Skeleton method 1 is different from the method 3: they both can utilize Arrangements for part suppression and controlling constraints but that is where the similarity ends. Method 3 does not use any visible structure but rely on the constraints instead. While the complicity of the first method is in its skeleton and modifying of it, method 3 is more fragile to changes. However, both of these disadvantages can be removed by giving appropriate training and instructions. Since neither of these methods is perfect, method 3, the one without the skeleton, has an advantage of being more flexible and simple.

The method 3 is chosen because it is simple, more flexible and can be used with Arrangements. Especially older designers or the ones who are switching from 3D CAD software would benefit of simple assemblies made without extra parts or sketches. The flexibility of the method allows implementing more rules or further simplifying the way of assembly in the future. Module structure may also change in the future which would not need many changes to the method compared to skeleton one. Assembly Arrangements is a powerful tool, as stated before, and with method 3 it is possible to fully utilize its functions.

6.1 Software Challenges While Researching

Many challenges were met along the way. Some of them affected the results, others not. Next a couple of software challenges are presented which did not affect the results but took a lot of time to deal with.

6.1.1 PLMXML Error

While working with assemblies, one of them unexpectedly showed in BOM all of the parts included in the assembly despite the fact that some of them were hidden using “Reference only” –option. Advice from the company was to try to check an option “Synchronize Assembly Arrangements” under Assembly –tab in Teamcenter Integration for NX, under Customer defaults in NX. That helped for most of the items but did not solve the problem.

After some time receive an error message was received (Figure 19) while trying to save any assembly. The error message was about arrangements but even the new assemblies without arrangements received an error. Reinstalling of Teamcenter and NX didn’t helped but later on the problem was solved by unchecking the option mentioned before. Came out that uninstalling the programs doesn’t delete user settings where the problem was.

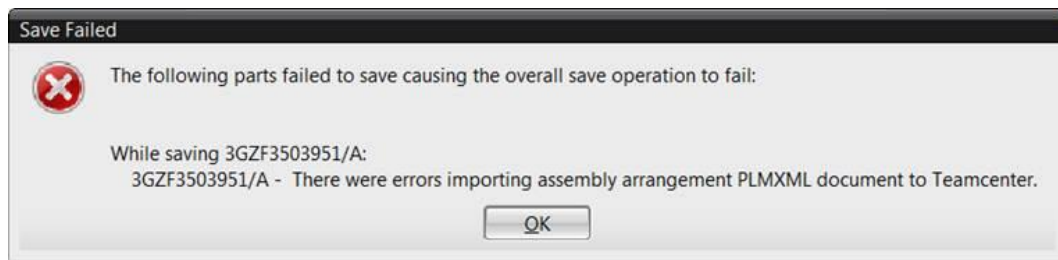

Figure 19. PLMXML Error on save.

6.1.2 Licenses

From time to time there were not enough modeler module licenses. The problem wasn't an amount of licenses but their distribution among users. Sometimes all of modeler licenses were in use. It was unfortunate but with limited resources nothing else but waiting could be done until some users would release their licenses.

7 OTHER POSSIBILITIES

While searching for different ways to create modular 3D assemblies a few other features of Teamcenter and NX were found which can be utilized in the future.

7.1 Teamcenter Variants

Teamcenter has its own techniques of managing variants: classic variants and modular variants. The classic variants are suitable if the product is non- modular or the scope of the assemblies is limited. The modular variants may be used when there is need to enforce modularity to facilitate the reuse of lower level assembly. Integration with NX expressions is available with modular variants only.

Variants allow the user to create options and allowed values of these options as well as associate them with items. For example, assembly with a limited amount of variants and options can be controlled through Variants. Assuming the skeleton for the system is made and all the parts are tagged, the user can choose from drop-down list what kind of parts are needed and TC will generate the needed assembly.

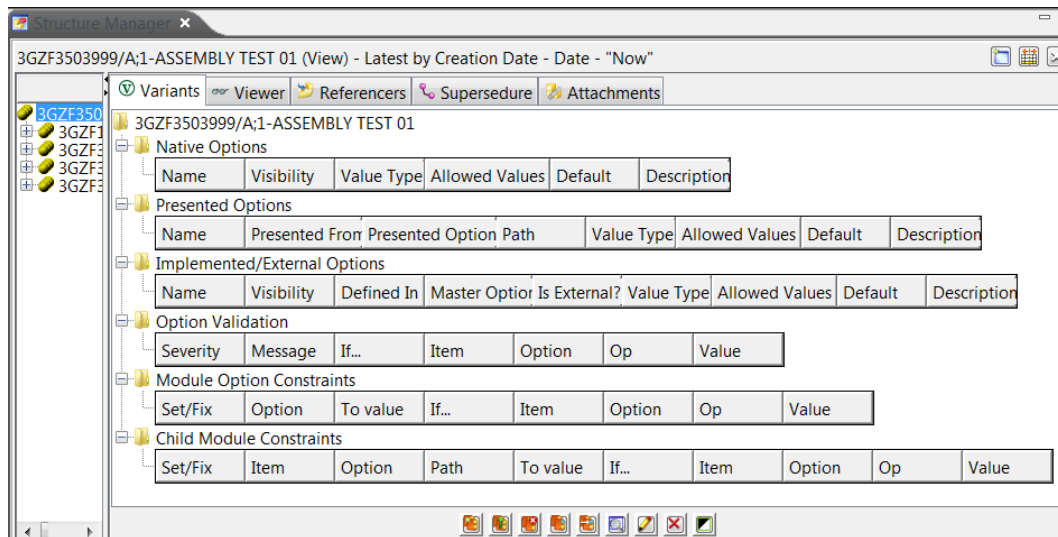

Figure 20. Variants default interface in Teamcenter.

7.2 Attributes and Expression Templates

It might be possible to create the skeleton which can be controlled by expressions. These user expressions would be linked to the attributes of the assembly part file. To create an assembly the end user would need to add all the modules into the assembly and choose from the drop list parameters of the motor /8/.

At this point of time and with such a variety of different motor modifications it would be difficult to keep the lists up-to-date and create these drop-down menus. NX is also not able to process serial drop-down lists, like when the next list changes accordingly to previously chosen value.

7.3 Product Interface

Product Interface allows to specify geometry and expressions in the part that should be used as references. The selection can be limited to specific edges, faces, coordinate systems or datum planes, or users can be encouraged to use ones as seen in Figure 21 /7/.

One of applications is using it on CSYSs or faces used for mating in an assembly to prevent other users from choosing wrong geometries or just for simplifying the assembly experience.

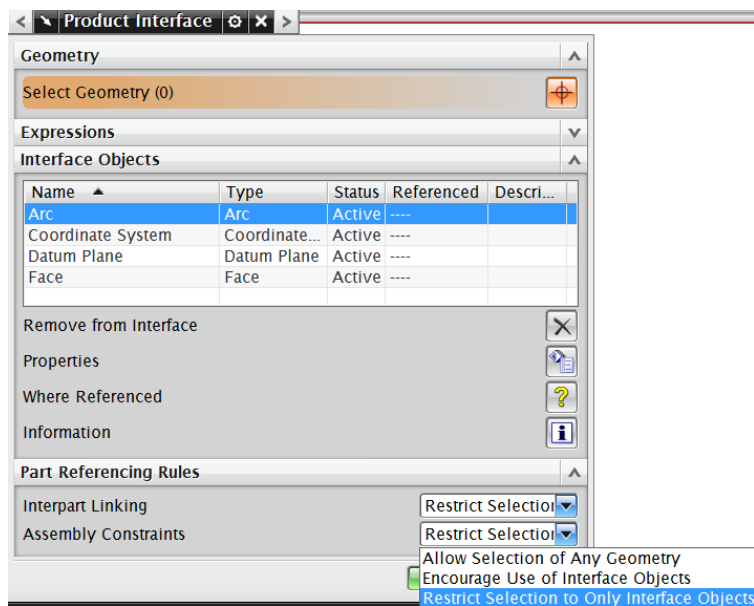

Figure 21. Product Interface.

7.4 Intelligent Assembly

One of the perfect scenarios would be when the main assembly would pick all the data from sub-assemblies and parts and generate a complete assembly based on them. The only constraints needed would be CSYS to CSYS, and even that might be possible to replace with drag and drop –functions or some kind of magnetic snap points.

This might be possible if all parts would have predefined expressions the values of which are specific values of the part. The sub-assembly would have a special skeleton where needed CSYS distances are specified with formulas which would extract values from the named expressions of the parts. The main assembly in its turn would have another skeleton which arranges sub-assemblies.

8 SUMMARY

The objective of this thesis was to make a research of modular assembly methods in Siemens NX8.0 CAD software and come up with a solution to improve assemblies in ABB M&G. In the beginning, a couple of possible solutions were found, and at some point a few more were taken under consideration. Some of these approaches were discarded right away and some of them were researched until the point when it was clear they are not useful for this kind of situation. The ones which had some potential were listed in Chapter 7, and three of the most suitable ones were researched and compared.

The choice of the most suitable approach was not easy. Methods had their advantages and disadvantages but making a bet on user experience versus of non-skeleton method versus technical superiority of skeleton method should be the right choice. Since at ABB M&G there are a lot of designers who are new to the NX, it is necessary they feel the method is more or less familiar. The non-skeleton method of assembly is close to the methods new users are introduced to when they are just learning 3D CAD software.

While there are many approaches on how to make modular assembly, restrictions were not helping at all. Neither of the methods discovered fitted perfectly for the case and, perhaps, there is no perfect solution for it. However, something had to be done and in this case choosing the lesser of two evils might be a solution, which will ease handling of big assemblies and work as the base for future researches.

The new versions of Siemens NX and Teamcenter come out nearly every year with new features and there will also be improvements for handling big assemblies. The new features should be checked out and also there are still a lot of functions in the current versions which should be found out and tested.

REFERENCES

- /1/ A Critical History of Computer Graphics and Animation. Accessed 28.1.2015. <http://design.osu.edu/carlson/history/lesson10.html>
- /2/ ABB Suomessa. Accessed 5.9.2014 <http://new.abb.com/fi/abb-lyhyesti/suomessa>
- /3/ Hantula, J. 2013. 3D-tuotesuunnittelu. [PDF]
- /4/ I-deas Evolution of Excellence. Accessed 28.1.2015. http://www.plm.automation.siemens.com/en_us/products/nx/ideas/
- /5/ Laakko, T. 1998. Tuotteen 3D-CAD suunnittelu. 1. painos. Porvoo. WSOY.
- /6/ Low voltage Process performance motors according to EU MEPS, Catalogue 11/2014.
- /7/ NX 8.0 Help files.
- /8/ NX CAD Quick Tips: Attributes and Expression Templates. Accessed 27.4.2015. https://www.youtube.com/watch?v=BraJx4Xy_Gw
- /9/ NX for Design: Advantages and Benefits. Accessed 10.3.2015. http://www.plm.automation.siemens.com/en_us/products/nx/for-design/advantages-benefits.shtml
- /10/ Peltonen, H. 2002. PDM: tuotetiedon hallinta. 1. painos. Helsinki. IT-Press.
- /11/ Risku, S. 2010. NX CAD-järjestelmän kokoonpanomallinnusmenetelmien tutkimustyö. Vaasa. Vaasan ammattikorkeakoulu.
- /12/ Teamcenter “unified”. Accessed 29.1.2015. http://www.plm.automation.siemens.com/en_us/Images/21848_tcm1023-100227.pdf
- /13/ TEAMCENTER: Simplifying PLM. Accessed 29.1.2015. http://www.plm.automation.siemens.com/en_us/products/teamcenter/library.shtml#lightview%26uri=tcm:1023-79817%26title=Teamcenter-Brochure-4680%26doctype=.pdf
- /14/ Tuhola, E. & Viitanen, K. 2008. 3D-mallintaminen suunnittelun apuvälineenä. 1. painos. Tampere. Tammertekniikka.
- /15/ Who we are - ABB in brief. Accessed 5.9.2014. <http://new.abb.com/about/abb-in-brief>