

General Product Support

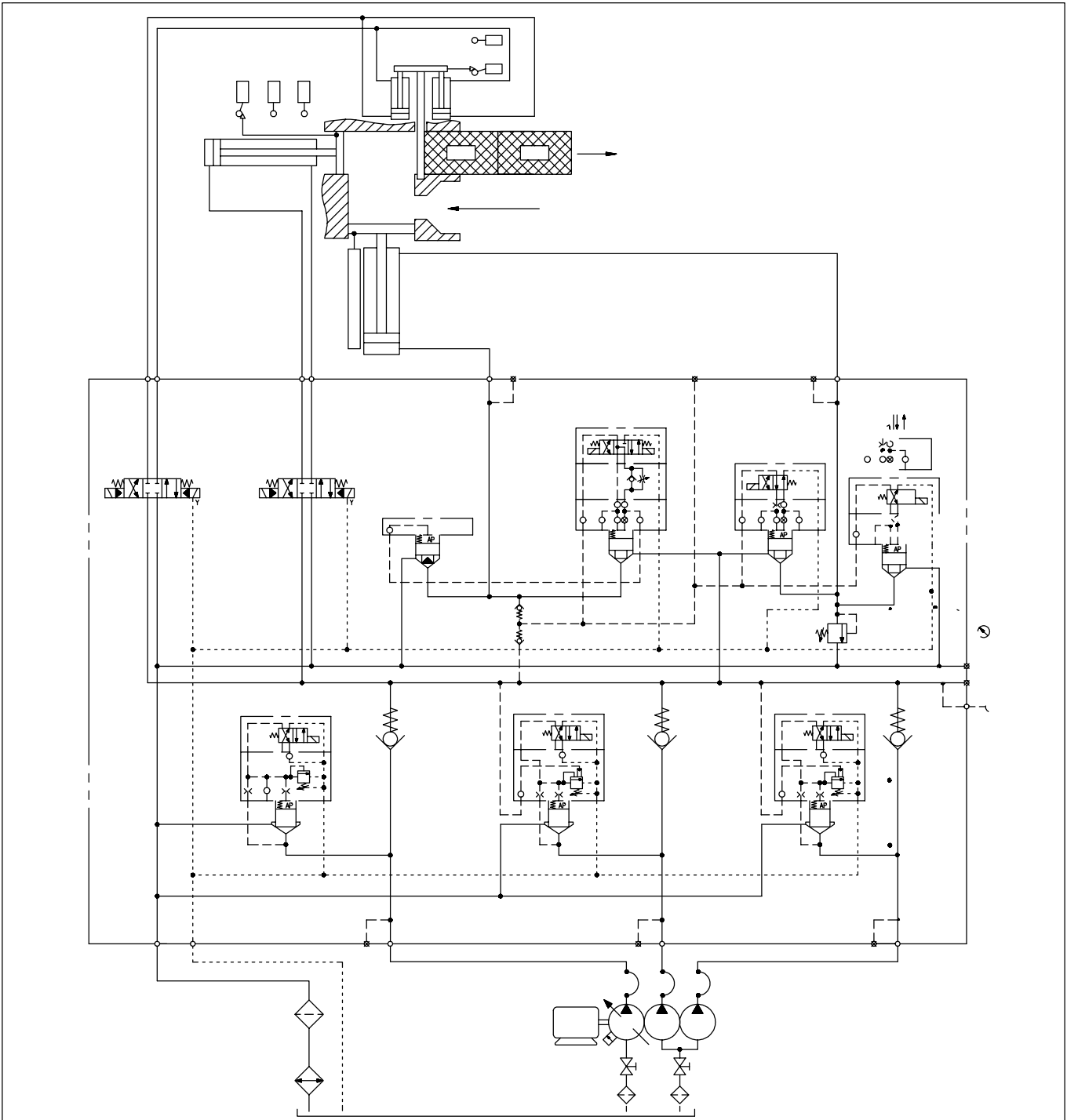

Hydraulic Hints & Trouble Shooting Guide



General Hydraulic Hints	3
Troubleshooting Guide & Maintenance Hints	4
Chart 1 Excessive Noise	5
Chart 2 Excessive Heat	6
Chart 3 Incorrect Flow	7
Chart 4 Incorrect Pressure	8
Chart 5 Faulty Operation	9
Quiet Hydraulics	10
Contamination Control	11
Hints on Maintenance of Hydraulic Fluid in the System	13
Aeration	14
Leakage Control	15
Hydraulic Fluid and Temperature Recommendations for Industrial Machinery	16
Hydraulic Fluid and Temperature Recommendations for Mobile Hydraulic Systems	19
Oil Viscosity Recommendations	20
Pump Test Procedure for Evaluation of Antiwear Fluids for Mobile Systems	21
Oil Flow Velocity in Tubing	23
Pipe Sizes and Pressure Ratings	24
Preparation of Pipes, Tubes and Fittings Before Installation in a Hydraulic System	25
ISO/ANSI Basic Symbols for Fluid Power Equipment and Systems	26
Conversion Factors	29
Hydraulic Formulas	29

General Hydraulic Hints

Good Assembly Practices

Most important – cleanliness.

All openings in the reservoir should be sealed after cleaning.

No grinding or welding operations should be done in the area where hydraulic components are being installed.

All cylinder, valve, pump and hose connections should be sealed and/or capped until just prior to use.

Mineral spirits should be kept in safety containers.

Air hoses can be used to clean fittings and other system components. However, the air supply must be filtered and dry to prevent contamination of the parts.

Examine pipe fittings and hose assemblies prior to use to be certain that burrs, dirt and/or scale are not present.

All pipe and tubing ends should be reamed to prevent restriction and turbulent flow.

Do not use Teflon tape on straight thread connections.

When installing pumps or motors, always align coupling halves as closely as possible, within 0.007 inch.

When using flexible couplings, follow the manufacturer's recommendations or allow 1/32 to 1/16 inch clearance between the coupling halves.

Do not drive couplings on pump or motor shafts. They should be a slip fit, or shrunk on using hot oil.

Always use a dry spray-on lubricant on splines when installing. This prevents wear and adds to the life of the splines.

When using double universal joint couplings, the shafts must be parallel and the yokes must be in line.

When installing V-belt pulleys on pumps or motors, line up both pulleys as closely as possible. Always install the pulleys with a minimum amount of overhang as close to the pump or motor face as possible. This increases bearing service life.

Pipes

Iron and steel pipes were the first kinds of plumbing used to conduct fluid between system components. At present, pipe is the least expensive way to go when assembling a system. Seamless steel pipe is recommended for use in hydraulic systems with the pipe interior free of rust, scale and dirt.

Early classifications of pipe wall thicknesses were: standard, extra heavy and double extra heavy.

Today, pipes are classified by schedule number as specified by the American National Standards Institute (ANSI). The schedule numbers vary from 10 through 160. The larger the number, the heavier the wall thickness. The outer pipe diameter stays the same for a given pipe size, while the inside opening becomes smaller as schedule number increases.

A comparison of early classifications versus the ANSI classification follows:

Standard	– Schedule 40
Extra Heavy	– Schedule 80

The double extra heavy classification does not compare with a schedule number. However, the inside diameter of a double extra heavy pipe is approximately one half that of a schedule 160 pipe.

In many cases, flanges are welded to the pipe ends and gaskets or "O" rings are used to seal the connections. Various pipe fittings are used to route the piping to and from each system component. These fittings can be threaded or welded in place as the need arises. Threaded connections are used in low pressure applications and welded connections are used if high pressure, high temperature, or a severe mechanical load exists.

All piping should be secured with clamps to prevent vibration and excessive stress due to the weight of the fluid. Do not weld the clamps to the pipe as it may weaken the pipe and cause a stress crack.

Tubing Do's And Don'ts

Don't take heavy cuts on thin wall tubing with a tubing cutter. Use light cuts to prevent deformation of the tube end. If the tube end is out or round, a greater possibility of a poor connection exists.

Ream tubing only for removal of burrs. DO NOT over ream tubing as it can weaken the connection.

Do not allow chips to accumulate in the tubing. They can be difficult to remove after bending.

Follow the manufacturers recommendations on the use of flaring tools. Don't overtighten the feed screw handle on a compression type flaring tool. Improper use of a tool can cause washout and/or splitting of the flare connection.

Bend tubing instead of cutting and using a fitting. This reduces pressure drop and minimizes system losses. The minimum radius of a tubing bend should be at least three times the inside diameter of the tube. Larger bends are preferred.

Sketch the optimum tubing route before beginning the bending process. Be sure to use tubing with the proper temper to prevent wrinkles and flattened bends.

Most flares are made by hand or power tools that swage the tube end over a split die. The standard flare angle is 37 degrees from the centerline. For best results, heavy wall tubing should be cut, deburred, and flared and bent using power equipment.

For information on sealing technology, or how to prevent leakage of hydraulic fluid, refer to "Leakage Control" in this catalog.

Troubleshooting Guide & Maintenance Hints

General

The troubleshooting charts and maintenance hints that follow are of a general system nature but should provide an intuitive feeling for a specific system. More general information is covered in the following paragraphs. Effect and probable cause charts appear on the following pages.

System Design

There is, of course, little point in discussing the design of a system which has been operating satisfactorily for a period of time. However, a seemingly uncomplicated procedure such as relocating a system or changing a component part can cause problems. Because of this, the following points should be considered:

1. Each component in the system must be compatible with and form an integral part of the system. For example, an inadequate size filter on the inlet of a pump can cause cavitation and subsequent damage to the pump.
2. All lines must be of proper size and free of restrictive bends. An undersized or restricted line results in a pressure drop in the line itself.
3. Some components must be mounted in a specific position with respect to other components or the lines. The housing of an in-line pump, for example, must remain filled with fluid to provide lubrication.
4. The inclusion of adequate test points for pressure readings, although not essential for operation, will expedite troubleshooting.

Knowing the System

Probably the greatest aid to troubleshooting is the confidence of knowing the system. The construction and operating characteristics of each one should be understood. For example, knowing that a solenoid controlled directional valve can be manually actuated will save considerable time in isolating a defective solenoid. Some additional practices which will increase your ability and also the useful life of the system follow:

1. Know the capabilities of the system. Each component in the system has a maximum rated speed, torque or pressure. Loading the system beyond the specifications simply increases the possibility of failure.
2. Know the correct operating pressures. Always set and check pressures with a gauge. How else can you know if the operating pressure is above the maximum rating of the components? The question may arise as to what the correct operating pressure is. If it isn't correctly specified on the hydraulic schematic, the following rule should be applied:

The correct operating pressure is the lowest pressure which will allow adequate performance of the system function and still remain below the maximum rating of the components and machine.

Once the correct pressures have been established, note them on the hydraulic schematic for future reference.

3. Know the proper signal levels, feedback levels, and dither and gain settings in servo control systems. If they aren't specified, check them when the system is functioning correctly and mark them on the schematic for future reference.

Developing Systematic Procedures

Analyze the system and develop a logical sequence for setting valves, mechanical stops, interlocks and electrical controls. Tracing of flow paths can often be accomplished by listening for flow in the lines or feeling them for warmth. Develop a cause and effect troubleshooting guide similar to the charts appearing on the following pages. The initial time spent on such a project could save hours of system down-time.

Recognizing Trouble Indications

The ability to recognize trouble indications in a specific system is usually acquired with experience. However, a few general trouble indications can be discussed.

1. Excessive heat means trouble. A misaligned coupling places an excessive load on bearings and can be readily identified by the heat generated. A warmer than normal tank return line on a relief valve indicates operation at relief valve setting. Hydraulic fluids which have a low viscosity will increase the internal leakage of components resulting in a heat rise. Cavitation and slippage in a pump will also generate heat.
2. Excessive noise means wear, misalignment, cavitation or air in the fluid. Contaminated fluid can cause a relief valve to stick and chatter. These noises may be the result of dirty filters, or fluid, high fluid viscosity, excessive drive speed, low reservoir level, loose intake lines or worn couplings.

Maintenance

Three simple maintenance procedures have the greatest effect on hydraulic system performance, efficiency and life.

1. Maintaining a clean sufficient quantity of hydraulic fluid of the proper type and viscosity.
2. Changing filters and cleaning strainers.
3. Keeping all connections tight, but not to the point of distortion, so that air is excluded from the system.

Guidelines

The following charts are arranged in five main categories. The heading of each one is an effect which indicates a malfunction in the system. For example, if a pump is exceptionally noisy, refer to Chart 1 titled Excessive Noise. The noisy pump appears in Column A under the main heading. In Column A there are four probable causes for a noisy pump. The causes are sequenced according to the likelihood of happening or the ease of checking it. The first cause is cavitation and the remedy is "a". If the first cause does not exist, check for cause number 2, etc.

Troubleshooting Guide & Maintenance Hints

Chart 1

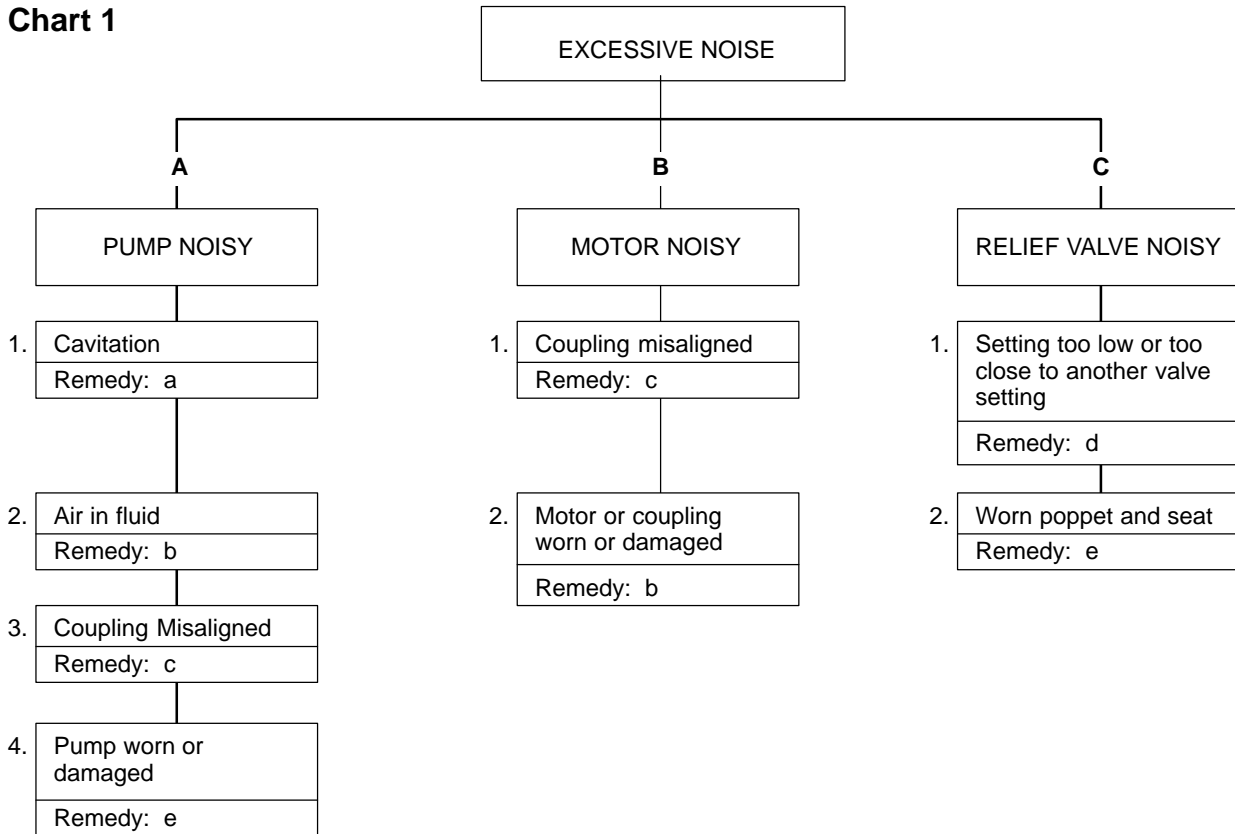

Remedies:

a. Any or all of the following:

Replace dirty filters; wash strainers in solvent compatible with system fluid; clean clogged inlet line; clean or replace reservoir breather vent; change system fluid; change to proper pump drive motor speed; overhaul or replace supercharge pump; fluid may be too cold.

b. Any or all of the following:

Tighten leaking connections; fill reservoir to proper level (with rare exception all return lines should be below fluid level in reservoir); bleed air from system; replace pump shaft seal (and shaft if worn at seal journal).

c. Align unit and check condition of seals, bearings and coupling.

d. Install pressure gauge and adjust to correct pressure.

e. Overhaul or replace.

Troubleshooting Guide & Maintenance Hints

Chart 2

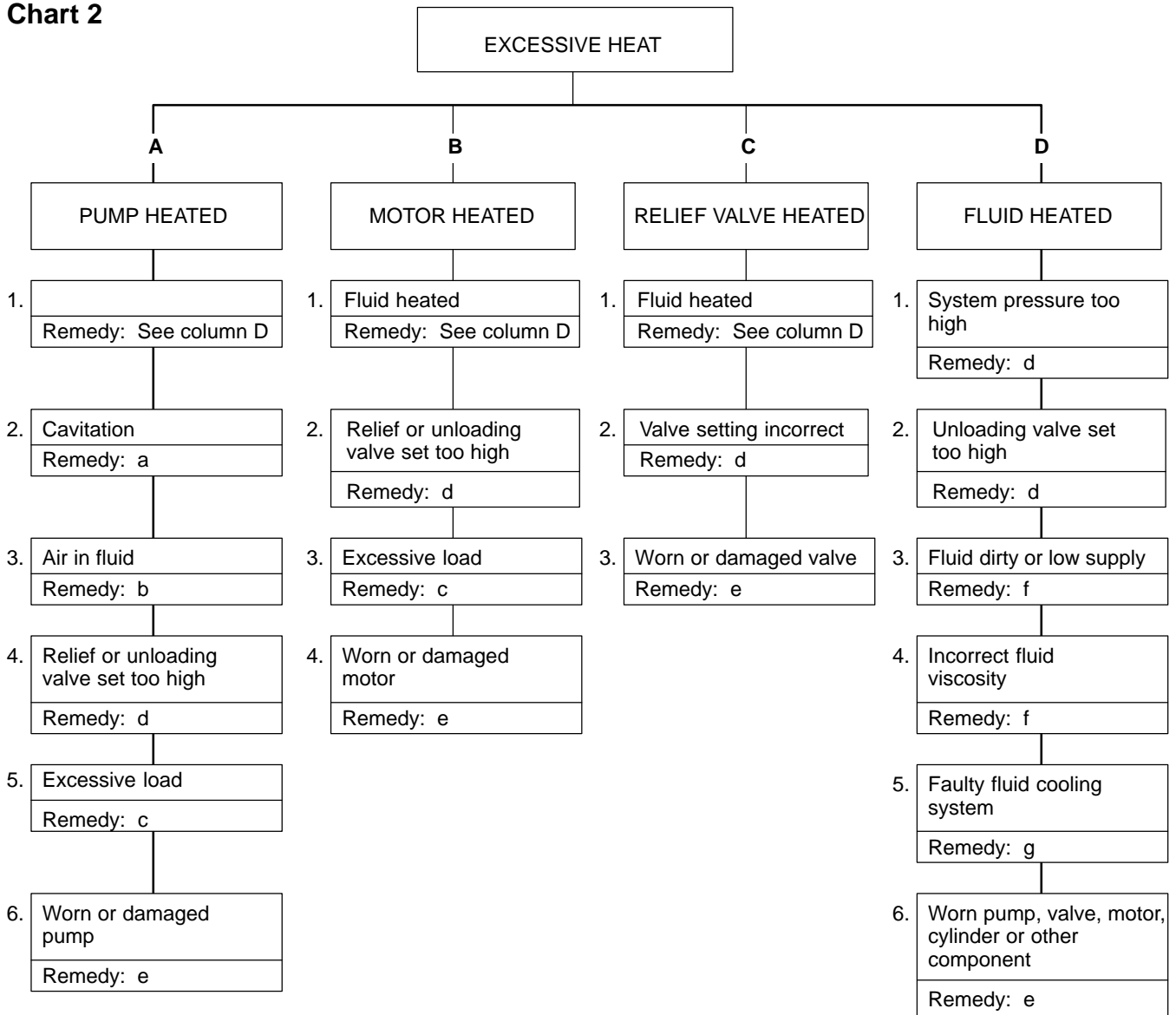

Remedies:

a. Any or all of the following:

Replace dirty filters; clean clogged inlet line; clean or replace reservoir breather vent; change system fluid; change to proper pump drive motor speed; overhaul or replace supercharge pump.

b. Any or all of the following:

Tighten leaking connections; fill reservoir to proper level (with rare exception all return lines should be below fluid level in reservoir); bleed air from system; replace pump shaft seal (and shaft if worn at seal journal).

c. Align unit and check condition of seals and bearings; locate and correct mechanical binding; check for work load in excess of circuit design.

d. Install pressure gauge and adjust to correct pressure (keep at least 125 PSI difference between valve settings).

e. Overhaul or replace.

f. Change filters and also system fluid if improper viscosity; fill reservoir to proper level.

g. Clean cooler and/or cooler strainer; replace cooler control valve; repair or replace cooler.

Troubleshooting Guide & Maintenance Hints

Chart 3

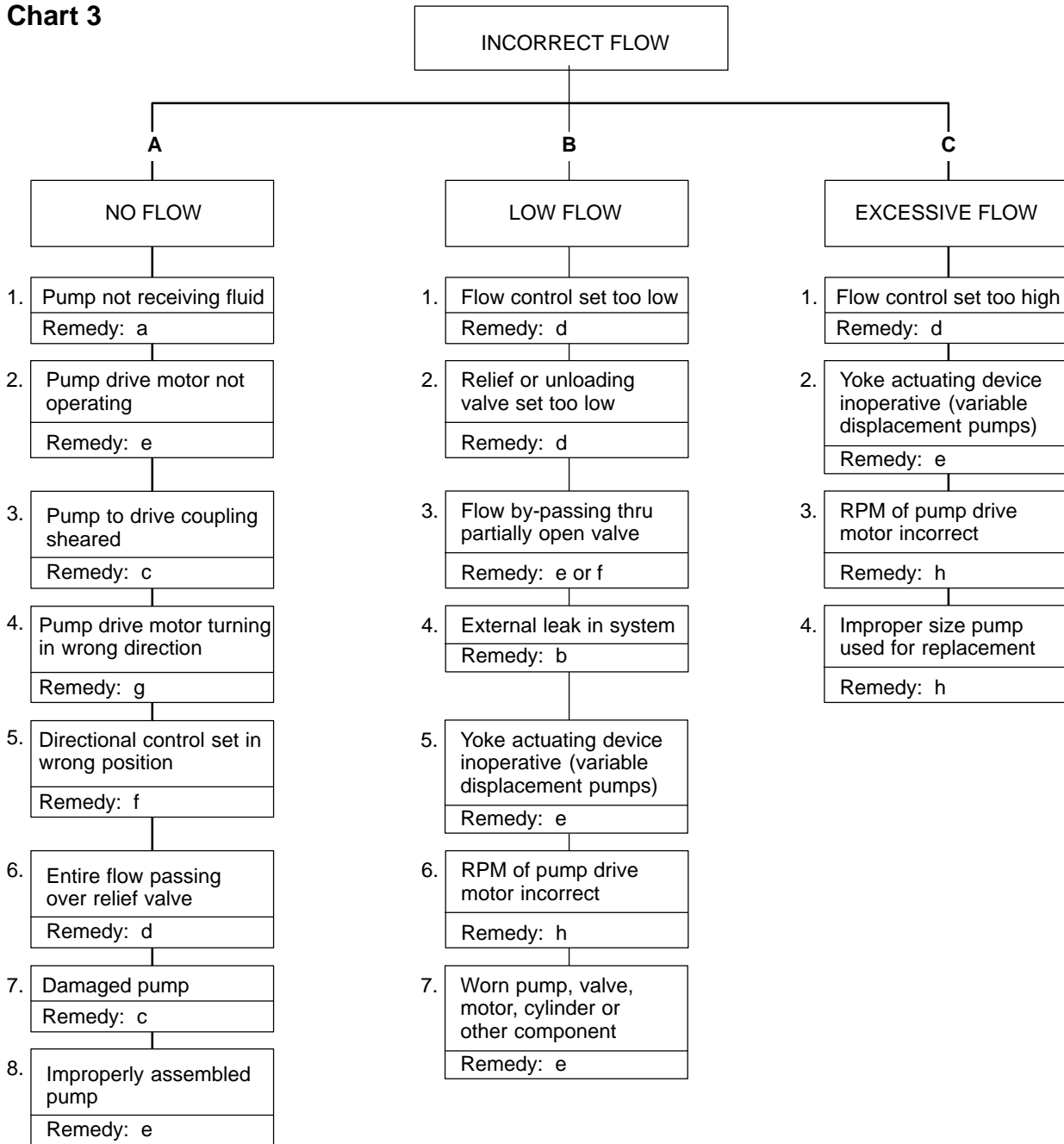

Remedies:

- a. Any or all of the following:
Replace dirty filters; clean clogged inlet line; clean or replace reservoir breather vent; fill reservoir to proper level; overhaul or replace supercharge pump.
- b. Tighten leaking connections.
- c. Check for damaged pump or pump drive; replace and align coupling.
- d. Adjust.
- e. Overhaul or replace.
- f. Check position of manually operated controls; check electrical circuit on solenoid operated controls; repair or replace pilot pressure pump.
- g. Reverse rotation.
- h. Replace with correct unit.

Troubleshooting Guide & Maintenance Hints

Chart 4

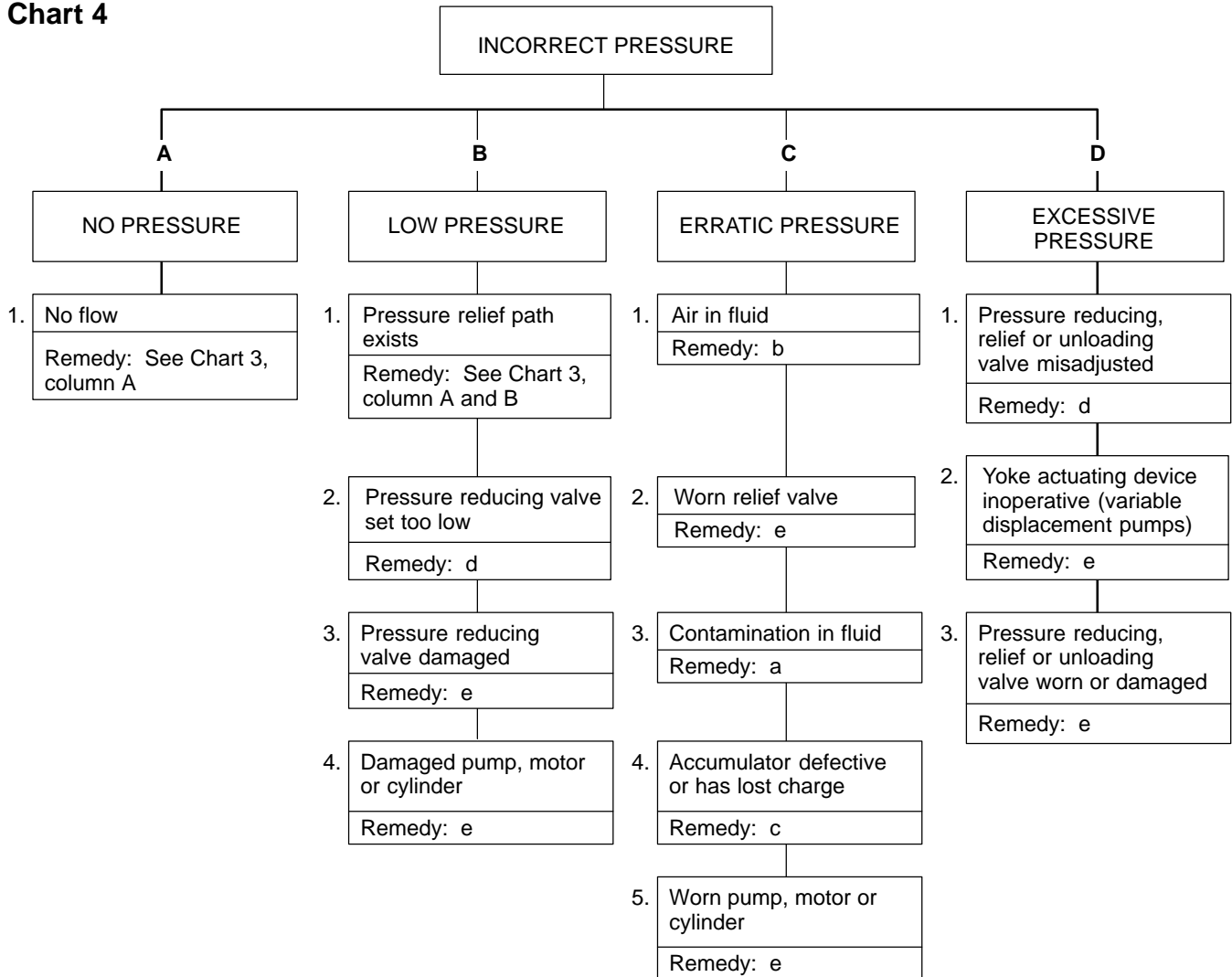

Remedies:

- a. Replace dirty filters and system fluid.
- b. Tighten leaking connections (fill reservoir to proper level and bleed air from system).

Troubleshooting Guide & Maintenance Hints

Chart 5

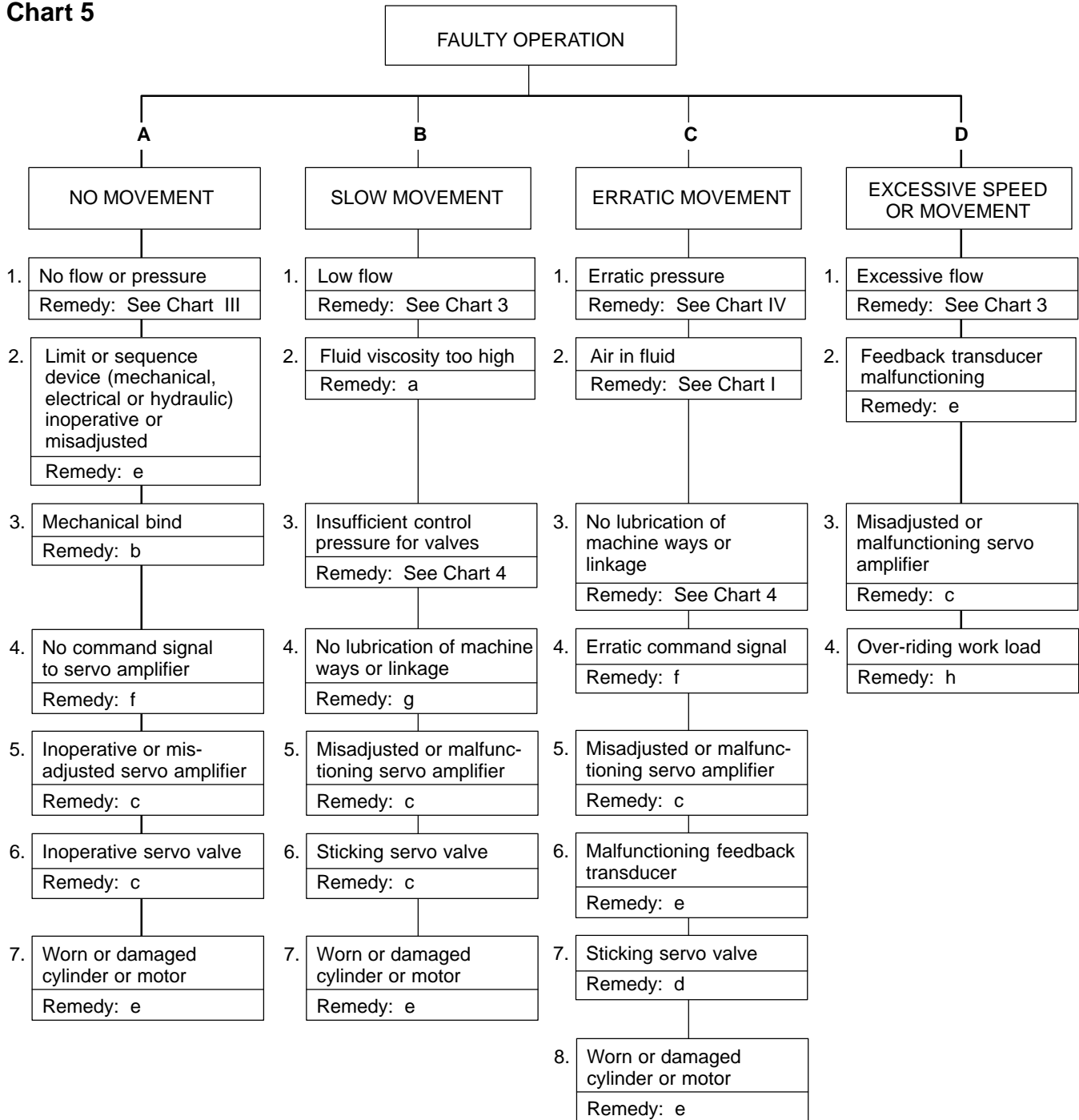

Remedies:

- | | | |
|---|---|---|
| <p>a. Fluid may be too cold or should be changed to clean fluid of correct viscosity.</p> <p>b. Locate bind and repair.</p> | <p>c. Adjust, repair or replace.</p> <p>d. Clean and adjust or replace; check condition of system fluid and filters.</p> <p>e. Overhaul or replace.</p> | <p>f. Repair command console or interconnecting wires.</p> <p>g. Lubricate.</p> <p>h. Adjust, repair or replace counterbalance valve.</p> |
|---|---|---|

Quiet Hydraulics

Today, buyers are demanding quiet machines because of their concern about meeting industry's noise limits. Vickers is helping to meet this demand by supplying quiet hydraulic components. Sound levels of some pumps today, for example, are fifty percent lower than the same model pumps of a few years ago.

Sound Advice

Producing quiet, hydraulically-actuated machines requires more than just the use of quiet components.

Meeting the stringent sound-level specifications of today's industrial hydraulic systems and machines takes careful engineering. The pump should be considered first. It not only produces sound directly but generates vibrations and fluid pulsations. These react with other machine parts which produce more sound.

Pump Selection

Pumps generate more acoustic energy per unit of hydraulic power by running at high speed rather than at low. For this reason, a pump should operate at 1200 RPM whenever sound is critical. Below 3000 PSI, the trade-off between pressure and pump size for a given drive power has little effect on noise, so you are free to select any combination of these factors that otherwise meet your needs.

Mechanical Isolation

To meet lower sound level limits, the pump should be mechanically isolated from the rest of the machine using anti-vibration mountings. This also requires that all connections to the pumps be made with flexible hose.

Flexible hose will often reduce noise even where anti-vibration mountings are not used. It prevents vibrations from reaching other lines and components to keep them from becoming sound sources. In long lengths, this hose is, itself, a good sound generator so only short lengths should be used. For long runs, use solid pipes with short hoses at the ends. All long lines must be supported every meter or so, preferably with clamps providing vibration damping. Lines must not contact panels that are good sounding boards. Where they pass through such panels, allow sufficient clearance to prevent direct contact; never use bulkhead fittings in such cases.

Acoustic Isolation

The greatest sound level reductions are attained with the pump acoustically as well as mechanically isolated. This requires that the pump be completely enclosed in a non-porous shell weighing at least 10 kg per square meter of surface. No openings can be tolerated and all joints must be sealed with resilient gaskets or moldings.

Grommets of rubber or other soft material should be used to close openings around piping and to prevent mechanical contact between the enclosure and piping. It must be emphasized that while mechanical isolation by itself can reduce noise, acoustic isolation can only be effective when used in combination with mechanical isolation.

Fluids

The condition of the fluid being pumped is also important in controlling sound. Fluid viscosity, temperature and vacuum by themselves have no effect on sound levels. It is important to control them, however, to prevent the formation of entrained air or vapor bubbles that can double sound levels, and reduce pump life.

A combination of high fluid temperature and inlet vacuum generates what are called cavitation bubbles. However, at low temperatures, a high viscosity fluid in a very long suction line can also produce sufficient vacuum to cause cavitation. Important methods of suppressing bubble formation include: Using short runs or large diameter inlet lines; keeping the reservoir elevation close to or above that of the pump; using low pressure-drop inlet filters that signal when they are producing high vacuums and need changing; and, providing adequate fluid controls. These are all good hydraulic practices that become increasingly important where you must achieve low sound levels.

Reservoirs

Reservoirs provide the means for releasing entrained bubbles. These can come from sources other than the pump inlet and are usually present in the fluid returning to the reservoir. It is important to note that low reservoir temperatures reduce the rate of bubble escape and may result in incomplete release. As pointed out earlier, high temperatures promote bubble formation. The best balance between these two alternatives is achieved by maintaining the temperature of oil leaving the reservoir in the range of 120° to 150° F and the temperature of water-based fluids between 100° and 120° F.

A simple reservoir has to be large to effect complete bubble release. By providing baffles to guide the fluid through a circuitous path and by locating return and pump inlet lines as far apart as possible, a reservoir holding between two to three minutes of maximum pump flow can be adequate.

Contamination Control

Contaminant in hydraulic systems is now recognized as the most frequent cause of malfunction or failure of hydraulic equipment. Dependent on the nature, size and/or amount of contaminant, it can cause:

- Reduced component service life.
- Machine malfunction, particularly when operating near maximum capacity.
- Risk of frequent breakdowns under the same conditions.
- Production rates below schedule.
- High product scrap rates and quality faults.

Nature of Contaminant

Contaminant can be either particle contaminant or the product(s) of fluid degradation.

Particle contaminant can be metal, rubber, plastic, dirt, dust, fibre, sand, paint, etc.; several types may be present at any time. It can enter the fluid at any time after the fresh clean fluid has been produced by the fluid manufacturer. There is usually little likelihood that fresh fluid became contaminated during the refining and blending processes.

Fluid degradation results in:

- Oxidation and/or the formation of gummy deposits and sludge from the combined effects of high temperatures, air, water and particle contaminant. These can increase viscosity, cause gummy deposits to coat moving parts, clog orifices and small passages, thus impairing smooth mechanical movements and form sludge.
- Unstable emulsions of poor lubricity formed when water accidentally emulsifies with oil. These impair smooth movements and promote wear.
- Aeration or air bubbles in the fluid, particularly at low pressures. In excess, they cause noise in pumps and valves leading to erratic or spongy machine movements, premature wear and failure.

Control of Contamination

The following table prescribes preventative measures relative to the different common types and causes of contamination. For additional information, request Vickers Guide to Systemic Contamination Control, catalog 561.

Preventive Measures	Fluid degradation by:			
	Solid Contam.	High Temp.	Water	Air
For Storage Drums: <ul style="list-style-type: none"> – Store in cool, dry location. – Ensure that closures fully seal in the fluid. – Wipe away any dirt and moisture from around the closure <i>before</i> loosening and emptying. – Use a portable filtration and transfer unit for emptying and refilling. 	•	•	•	
For Storage Tanks: <ul style="list-style-type: none"> – Install in cool, dry location. – Ensure that all covers and stop valves effectively seal in the fluid. – Keep filling lines clean; cap ends when not in use. – Use a portable filtration unit for filling and emptying. 	•	•	•	
For Hydraulic Systems: <ul style="list-style-type: none"> – Provide fluid filter(s) in location(s) that assure the required protection. – The ideal steady-state flow conditions through an off-line filter make this a <i>must</i> for most applications. – Whenever possible, use filters having element condition indicators. – Vented systems must be fitted with an air breather appropriate to the environment(s) in which the machine is to be operated and the requirements of the system. – Fit strainers to pump inlet lines if there is risk of large contaminant particles (i.e. string, rag, screws, etc.) entering the lines. – Prevent air entering the system, particularly through pump inlet lines. Ensure air-tight joints in any sub-atmospheric zone or pump inlet lines. Also make sure that those lines and all return and drain lines terminate below the minimum fluid level in the reservoir; pump inlet lines should be sufficiently below to prevent air entering through a vortex at low fluid levels. – Design for, and maintain, fluid temperatures at optimum levels for the application. Apply coolers if necessary. – Locate or screen hydraulic systems away from high temperature sources (e.g. furnaces). – Assemble system in clean conditions using clean practices. – Pre-clean pipes and reservoir immediately before installation. Cap any ends that cannot immediately be connected to mating components (e.g. between shifts). 	•		•	•

Preventive Measures	Fluid degradation by:			
	Solid Contam.	High Temp.	Water	Air
For Hydraulic Systems:				
– Remove protective caps only just before connecting mating components.	•		•	
– Use a portable filtration and transfer unit to fill the reservoir system.	•			
– Flush new systems, and those that have undergone major repairs, before starting up. Temporarily remove actuators and replace with flushing manifolds or valves. Servo valves and similar high precision units should also be replaced with flushing manifolds or valves for flushing operations. Make sure that actuators are clean internally before connecting to the system.	•			
– Make sure that air breathers and reservoir covers are at all times properly installed and tightly secured.	•		•	
– Stop any leakage of water into the system from coolers or other sources. Make a leak-tight repair.			•	
– By planned maintenance, ensure that clean filter elements are applied (or metallic elements cleaned when appropriate) when indicators or visual inspection shows this to be necessary.	•	•	•	
– Take fluid samples periodically and analyze to determine whether effects of particle contaminant, heat, water and air indicate need for more control of those factors or replacement of the fluid.	•	•	•	•
– Whenever the reservoir is emptied, clean it out thoroughly and remove all residual contaminant. If necessary, restore protective paint or other finishes. On completion, cap all openings unless the system is to be refilled immediately.	•		•	

Hints On Maintenance Of Hydraulic Fluid In The System

Hydraulic Fluid Changes

Good maintenance procedures make it mandatory to keep the hydraulic fluid clean. A daily, weekly or monthly log should be kept on the hydraulic fluid condition.

No hard and fast rules can be established for changing the fluid because of the great variety of operating conditions. However, we do know that when filter elements are replaced frequently, service life of a system increases. Periodic testing of the fluid by the supplier is recommended to confirm suitability for continued use and to establish the correct fluid and filter element replacement interval.

Some of the considerations affecting hydraulic fluid are: operating temperature, type of service, contamination levels, filtration, and the chemical composition of the fluid.

Fluid Recommendations

The basic recommendations for fluid are stipulated in the Hydraulic Fluid and Temperature Recommendations for Industrial Machinery in this catalog. The fluids recommended give the assurance of adequate wear protection and excellent chemical stability under the most adverse operating conditions.

On mobile applications, the viscosity grade of the fluid should be changed in spring and autumn as is done with automotive engines. Hydrostatic transmissions and control mechanisms may require a different viscosity fluid. Fluid requirements are normally outlined in the original equipment manufacturers operation and maintenance manuals.

Draining The System

The system should be started and fluid heated before draining. This will lower the time it takes to drain the system and allow impurities suspended in the fluid to be removed. It is desirable to remove all fluid from the system. Bleeding of the fluid at the lowest point in the system will help in most cases.

Systems which have accumulated deposits that were not removed during draining must be flushed with a light viscosity fluid. The fluid should contain a rust inhibitor to protect metal surfaces against rust formation after draining.

When hydraulic fluid is added to replenish the system, it should be pumped through a 25 micron filter. If such a filter is not available, a funnel with a fine wire screen (200 mesh or

finer) can be used. It is important that fluid be clean and free of all substances which will cause improper operation.

Fluid Contamination – Causes and Effects Contamination

A contaminated system can be the result of several factors; system design inadequate, poor maintenance of the system, poor housekeeping of the system and adverse operating conditions.

System Design Inadequate

- Reservoirs which cannot be cleaned.
- Breathers that permit abrasives inherent in the atmosphere to enter the system.
- Poor cylinder packing design (no wiper to clean dirt from the piston rod).
- Improper piston rod design (piston rods with poor wear characteristic).
- Improper valving (anti-cavitation checks omitted from cylinder circuits with rapid drop characteristics).
- Failure to provide adequate filtration.

Poor Maintenance of the System

- Improper and unclean practices when adding fluid to the system.
- Failure to clean breathers.
- Failure to change pitted cylinder rods and worn cylinder packings.
- Failure to use good cleanliness practices when changing system components.
- Failure to change filter cartridges and/or filter at proper intervals.
- Failure to purge debris from the system after a pump failure.

Poor Housekeeping of the System

Surgical cleanliness is not required, however, ordinary clean practices during assembly will pay off in increased service life of the equipment.

Excessive and improper use of pipe thread sealer on lines and gaskets in the system can cause pump failures. This is especially true when a type of sealer is used that hardens.

Another source of contamination is fittings, hoses and lines which are received from a vendor uncapped. The use of brazed or welded fittings, and unpickled steel plating can also contribute to the contamination.

Preparation of pipes, tubes and fittings in this catalog should be referred to and followed. This will lower the possibility of premature failure due to contamination of the system.

Adverse Operating Conditions

From experience, we have found that machines used in a very dusty atmosphere and in windy areas require special components. For example, heavy duty breathers, chrome plated piston rods, plus frequent changes of the filter cartridges are also required.

Effects of Contamination

Contamination affects all types of hydraulic equipment adversely. Precision high tolerance parts are very susceptible to the effects of contamination. Dirty fluid causes wear which accelerates leakage and the development of heat in a system. Heat lowers the lubricity of a hydraulic fluid and causes additional wear.

If a hydraulic pump or motor should fail, the system becomes contaminated. Remove the unit for repair. The reservoir must be drained, flushed, and cleaned. All hoses, lines, cylinders and valves should be inspected for wear and particles of the unit that failed. Flush all components of the complete system to remove metallic particles.

Replace filter elements. Dispose of the fluid removed from the system and fill the reservoir with clean hydraulic fluid. Install a new or rebuilt unit and start-up the system. Allow the system to run for a period of time to verify normal operation. Filter elements should be changed after 40 or 50 hours of operation. This guarantees that the system is essentially clean and free of any residue of the failed unit.

A very good reference catalog on contamination is available titled Vickers Guide to Systemic Contamination Control. This catalog describes types and sources for contamination, effects of types and sizes of particles, specifying contamination levels, selecting a filter, locating a filter, design steps and worked examples of fluid sampling analysis. Order catalog 561 from your local Vickers representative.

Aeration

Aeration

Causes

The following are candidates for the formation of air in a system.

- Leaking inlet lines.
- Control valve “O” rings leaking.
- Shaft seal leakage.
- Leaking cylinder packings caused by cavitating cylinders.
- Turbulence or sloshing in the reservoir.
- Vortexing fluid in the reservoir
- Release of air suspended within the fluid.

Effects

Aeration can be in many forms; large bubbles, foam or in various degrees of suspension. It usually causes pump noise (cavitation). Small bubbles cause extreme and rapid ring wear, with corresponding vane tip wear. Larger bubbles cause vanes to collapse and pound. This pounding effect develops rippling in the ring and the ring will have a dull appearance. This is more apparent on straight vane rings which are hardened cast iron. With extreme aeration cases, the wear is so rapid that a ring and vanes can be destroyed within an hour. In many cases, a large step will be worn in the ring contour at the pressure quadrant. When the step reaches a depth where the vane extends and locks, the vane and/or ring will break. Also, the shaft can break where it enters the rotor if the torque is great enough.

Cures

Leaking Inlet Lines

- Pipe threaded fittings can be porous. Use an approved type of pipe thread sealer on all pipe threads.
- If the pump inlet flange surface is rough, scored or mutilated, air leakage past the “O” ring seal can result.

With any of the above defects, air can be pulled into the system.

Control Valve “O” Rings Leaking

“O” rings are used to seal against port leakage in many control valves. These seals can be checked by applying heavy grease around the part to be checked. If the noise stops, the trouble has been located and repair can be initiated.

On systems which have been operating at excessive high temperatures, the “O” rings can harden and take a set. If this occurs, air leakage can result. This is true not only in a pump, but also in the rest of the components of the system. Another factor enhancing air leakage is the actual fluid composition. Fluids which

have a high sulphur content tend to accelerate “O” ring hardness. This is one of the principle reasons for keeping system operating temperatures down. Normal operating temperature of a system is 90 degrees above ambient. When operating temperatures are in excess of this value, trouble may result. Maximum operating temperatures should be checked at the pump outlet port.

Shaft Seal Leakage

Most vane pumps are internally drained. The shaft seal cavity is connected to the pump inlet. Excessively high inlet vacuums can cause air leakage at the shaft seal. The maximum vacuum measured at the pump inlet should not exceed five inches of mercury.

Shaft misalignment can increase the probability of air leakage past the shaft seal. Universal jointed couplings or splined couplings can cause seal leakage if not properly aligned. Straight (direct) coupling should never be used.

The use of the wrong type of tools can cause distortion or mutilation of a shaft seal at installation. The outer diameter of the shaft should be lightly polished before installation to remove any burrs or roughness in the area of the shaft seal.

Shaft seals must be made of the correct material for a given application. A material that is not compatible with system fluid can deteriorate and result in a leakage problem.

Leaking Cylinder Packings Caused By Cavitating Cylinders

On applications where a rapid raise and lower cycle is experienced, air can enter the system through a cylinder rod seal. Vacuums in excess of 20 inches of mercury have been recorded in systems without anti-cavitation check valves. This is enough to force dirt particles past the shaft seal into the system with the air. An anti-cavitation check will allow flow from the reservoir to enter the rod area of the cylinder during a vacuum condition from developing. This will lower the possibility of fluid contamination through the rod seal of a working cylinder.

Turbulence or Sloshing in the Reservoir

Return lines, if improperly located, can cause turbulence and aeration. A Plexiglass window should be placed in the prototype reservoir to study flow conditions. Return lines emptying above the fluid level cause bubbles to form in the system. Return lines should always be terminated below the fluid level. Vehicle movement can cause sloshing within the reservoir.

Reservoir must be deep enough to prevent aeration.

Vortexing Fluid in the Reservoir

If the fluid level in the reservoir is low and the inlet demand is great, a vortex condition can develop which pulls air into the pump inlet. In a hydraulic system, vortexing is normally the result of low fluid or poor reservoir design.

One of the best ways of curing a vortex problem is to place an anti-cavitation plate over the outlet of the reservoir. This is a common piece of sheet metal at least 1/8 inch thick set over and above the outlet opening. This plate will allow flow into the outlet from a horizontal direction and effectively extends and enlarges the reservoir opening. This prevents the vortex condition from developing.

Release of Air Suspended in Fluid

There is considerable air suspended in cold hydraulic fluid. As the fluid warms, air is released into the system. A reduction of fluid pressure will also release air out of suspension. A simple relief valve poppet can create an orifice that increases velocity of the fluid and lowers its pressure. The reduced pressure condition releases air out of suspension into the system. Relief valves should be returned below the fluid level of the reservoir as far from the reservoir outlet as possible. This allows time for the air released by the relief valve to be removed before leaving the reservoir and entering the inlet area of the pump.

In some cases, special return line configurations are needed, or air bleed valves used, to remove air from the system.

A special baffle made of 60 mesh screen can be installed into the reservoir. This baffle should be positioned at a 30° angle in the reservoir so that inlet oil is above the screen and outlet oil is below the screen. The top of the screen should be below the reservoir fluid level far enough to prevent surface foam from coming in contact with the screen. Surface foam can penetrate through the screen into the outlet area. The screen baffle will eliminate all bubbles except the very small ones from the fluid if designed properly.

Leakage Control

Cost Of Leakage

Concern for safety at work and the rapidly increasing cost of oil makes industry sensitive to leakage. Leakage creates safety hazards, wastes costly oil, increases machine down-time, decreases production rates, generates product spoilage and increases replacement parts inventory. The cost of effective leakage control is minor when compared to the long term costs of leakage.

Leak-Free Design

Hydraulic systems do not need to leak. Today's designer must create a more leak resistant system, where static seal leakage should not occur and dynamic seal leakage will be controlled. Before presenting some design practices proved effective in stopping leaks, we should consider the sources of most leaks.

Cause Of Leaks

Almost all hydraulic system leaks occurring after extended service result from three conditions:

- Loosening of fittings and connectors by shock and vibration
- Wear of dynamic seals and mating parts especially in hydraulic cylinders
- Deterioration of the elastomer because of elevated fluid temperatures or an incompatibility with the hydraulic fluid

Combatting Shock And Vibration

Many things can be done to minimize leakage from loose fittings and connectors subject to shock and vibration:

1. Support all pipe lines with damped mountings to absorb both shock and vibration.
2. Reduce shock with low-shock valves or accumulators.
3. Use pressure controls with low override and strategically placed to protect all parts of the system.

4. Use a minimum number of fittings and connectors. Use welded joints wherever practical.
5. Use parallel thread connectors, tees and elbows in place of tapered pipe threads.
6. Use manifolds instead of individual lines wherever possible.
7. Specify proper bolt and plug torques for expected peak pressures to prevent surface separation and static seal nibbling.
8. Stress good workmanship to avoid poorly assembled fittings and connectors.

Reducing Dynamic Seal Wear

Most dynamic seals are well designed and will provide long, relatively leak-free service if given reasonable chance. Four things a designer can do to extend the life of dynamic seals are:

1. Eliminate side loads on cylinder rod and drive shaft seals.
2. Protect cylinder rods from abrasive dirt with scrapers, shields or rubber gaiters.
3. Provide the requisite filtration and easily cleaned reservoirs to prevent dirt build-up in the oil.
4. Keep cylinder rod and shaft speeds as low as possible.

Requirements For Static Seals

A static seal retains fluid between rigid, stationary surfaces. The seal must be compressed as with a gasket or deformed as with an "O" ring, to flow into the microcrevices in the mating surface and also raise the seal's internal stress level higher than the pressure to be sealed. When parts are not rigid enough or bolt preload is not high enough, the mating surfaces will separate under the action of fluid pressure, creating clearances of enlarging those that might exist because the sealing surfaces were not initially flat enough. With movement of mating surfaces, the static seal becomes a dynamic seal. Rough surfaces will wear the seal and changing clearances nibble seal edges.

Mounting Plates

When valve packages or subplates are bolted to mounting plates, the condition of the plate is important to obtain a satisfactory initial seal and prevent extrusion and wear. Requirements are:

- Flat mounting surfaces
- Good sealing surface finish -64 micro-inches with no radial scratches
- High enough bolt preload to prevent surface separation.

Preventing Seal Deterioration

Premature deterioration of the seal can result from other factors. A primary factor is excessive fluid temperature. A good guide is that seal life is halved by every 20° F. rise. The cure: Incorporate sufficient heat exchangers to keep fluid temperatures below 150° F.

Another factor may be compatibility of the fluid with the seal material where special fluids are used. If a doubt arises, contact your Vickers representative. The following brief review of seal materials may be helpful.

Nitrile (Buna N) is the most widely used and best all around elastomer for petroleum (mineral) oils, fuel and fire-resistant fluids – with the exception of phosphate esters.

Fluoroelastomer (Viton or Fluorel) costs more than Nitrile, can be used instead of Nitrile but has the added advantage of longer life when fluid temperatures consistently run above 150° F. It can be used with phosphate ester fluids (except Skydrol).

Polyurethane shows extrusion and abrasion resistance superior to Nitrile in petroleum oils, fuel and silicate esters, but deteriorates if contaminated with hot water.

Refer to "Stop Leaks" bulletin 394 for more comprehensive coverage of leakage control.

Hydraulic Fluid And Temperature Recommendations For Industrial Machinery

Unit Type	Viscosity	Anti-wear Characteristics
Inline Piston (Pumps & Motors)	<ul style="list-style-type: none"> Viscosity Grades: 32-68 cSt (150-315 SUS) @ 40°C. (104°F) Running: 13-54 cSt (70-250 SUS) At Start Up: 220 cSt (1000 SUS) Max. 	Antiwear type hydraulic oils such as: automotive crankcase oils having API letter designations "SE", "SF", "SG", or "SH" per SAE J183
Angle Piston Vane (Except MHT) Gear (Pumps & Motors)	<ul style="list-style-type: none"> Viscosity Grades: 32-68 cSt (150-315 SUS) @ 40°C. (104°F) Running: 13-54 cSt (70-250 SUS) At Start Up: 860 cSt (4000 SUS) Max. 	
◆ MHT (High Torque/ Low Speed Vane Motors)	<ul style="list-style-type: none"> Viscosity Grades: 32-68 cSt (150-315 SUS) @ 40°C. (104°F) Running: 13-54 cSt (70-250 SUS) At Start Up: 110 cSt (500 SUS) Max. 	

cSt: Centistokes

SUS: Saybolt Universal Seconds

- ◆ Adhere to the oil recommendations for MHT units rather than the pumps involved.
- Viscosity Grades are the standard viscosity grades listed in ASTM D-2422 titled "Viscosity System for Industrial Fluid Lubricants", but any intermediate viscosity is acceptable.

Selection Of Viscosity Grades

Use the following tabulation to determine the temperature extremes between which the viscosity grades can be used to remain within Vickers start-up and running viscosity range recommendations.

The SAE 10W grades fall between the 32 cSt (150 SUS) and 46 cSt (215 SUS) grades and the SAE 20-20W approximates the 68 cSt (315 SUS) grade.

Viscosity Grade 40°C (104°F)	Start Up 860 cSt (4000 SUS)	Start Up 220 cSt (1000 SUS)	Start Up 110 cSt (500 SUS)	Running 54 cSt (250 SUS) Max.	Running 13 cSt (70 SUS) Min.
32 cSt (150 SUS)	-12°C (11°F)	6°C (42°F)	14°C (58°F)	27°C (80°F)	62°C (143°F)
46 cSt (215 SUS)	-6°C (22°F)	12°C (54°F)	22°C (72°F)	34°C (94°F)	71°C (159°F)
68 cSt (315 SUS)	0°C (32°F)	19°C (66°F)	29°C (84°F)	42°C (108°F)	81°C (177°F)

General Data

Oil in hydraulic systems performs the dual function of lubrication and transmission of power. It constitutes a vital factor in a hydraulic system, and careful selection should be made with the assistance of a reputable supplier. Proper selection of oil assures satisfactory life and operation of the system components with particular emphasis on hydraulic pumps and motors. Generally, oil selected for use with pumps and motors are acceptable for use with valves. Critical servo valves may need special consideration.

Some of the factors especially important in the selection of oil for use in an industrial hydraulic system are:

1. The oil must contain the necessary additives to ensure high antiwear characteristics. Not all hydraulic oils contain these in sufficient amounts.
2. The oil must have proper viscosity to maintain adequate sealing and lubricating quality at the expected operating temperature of the hydraulic system.
3. The oil must have rust and oxidation inhibitors for satisfactory system operation.

Two specific types of oil meet the requirements of modern industrial hydraulic systems:

1. Antiwear type industrial hydraulic oils. A new generation of industrial hydraulic oils containing adequate quantities of antiwear compound is recommended by Vickers for general hydraulic service.

Hydraulic Fluid And Temperature Recommendations For Industrial Machinery

These oils are generally developed and evaluated on the basis of pump wear tests such as the Vickers 35VQ25A and ASTM D-2882. These oils offer superior protection against pump and motor wear and the advantage of long service life. In addition, they provide good demulsibility as well as protection against rust.

2. Automotive type crankcase oils having API letter designation "SE", "SF", "SG", "SH", per SAE J183.

The above classes of oils in the 10W and 20-20W SAE viscosity ranges are for severe hydraulic service where there is little or no water present. The only adverse effect is that the "detergent" additive tends to hold water in a tight emulsion and prevents separation of water, even on long time standing.

Automotive type crankcase oils generally exhibit poorer shear stability which could result in some loss of viscosity during their service life. More shear stable multiple viscosity industrial grade hydraulic fluids will provide improved viscosity control.

Over the years, Vickers hydraulic oil recommendations have been based on oils that: (1) provide adequate wear protection, (2) have proper viscosity, and (3) are sufficiently stable to withstand the chemical, thermal and mechanical stresses of severe hydraulic service. There are automotive crankcase oils that are outside of the API SE, SF, SG and SH classes that meet the above basis of recommendation.

With these oils, it is highly desirable to have acceptable data from pump wear tests (35VQ25A and ASTM-D-2882). In exceptional cases where the requirements of speed, pressure, temperature and ambient conditions exceed the recommendations for industrial machinery, please refer to the oil recommendations. These fluids must also pass the Vickers 35VQ25 pump test.

Viscosity

Viscosity is the measure of the fluid's resistance to flow. The selection of a hydraulic oil of specific viscosity range must be based on the needs of the system, limitations of critical components, or proper performance of specific types of units. Vickers recommends that certain

maximum and minimum viscosity ranges of the oil at start-up and during running be maintained. (See chart) Very high viscosities at start-up temperatures can cause noise and cavitation damage to pumps. Continuous operation at moderately high viscosities will tend to hold air in suspension in the oil as well as generate higher operating temperatures. This can cause noise and early failure of pumps, motors and erosion of valves. Low viscosities result in decreased system efficiency and impairment of dynamic lubrication which causes wear.

Choose the proper oil viscosity for your particular system so that over the entire temperature range encountered, the start-up viscosity and the running viscosity range shown in the chart is met. This is important, and assurance should be obtained from your oil supplier that the viscosity of the oil being used will not be less than the minimum recommended at maximum oil temperature encountered.

A number of antiwear hydraulic oils containing polymeric thickeners (V.I. improvers) are available and are used for low temperature application. The temporary and permanent viscosity loss of some of these oils at operating temperature may adversely affect the life and performance of components. Be certain you know the extent of loss of viscosity (shear stability) of polymer containing oils under hydraulic service before using them so that you do not operate below the recommended minimum viscosity. The selection of an oil with good shear stability, is recommended for low temperature applications.

Temperature

To obtain optimum service life from both the oil and the hydraulic system, operate between 49°C (120°F) and 54°C (130°F). The maximum oil temperature normally recommended is 66°C (150°F).

MHT motors are permitted to operate at higher temperatures, but this is permissible by meeting special application requirements. For this service, oils should have antiwear characteristics required to pass pump test on page 20. Pumps can be approved to operate MHT motors at these higher temperatures. Contact your Vickers representative for recommendations.

Cleanliness

Thorough precautions should always be observed to ensure that the hydraulic system is clean.

1. Clean (flush) entire system to remove paint, metal chips, welding shot, lint, etc.
2. Filter each change of oil to prevent introduction of contaminant into the system.
3. Provide continuous oil filtration to remove sludge and products of wear and corrosion generated during the life of the system.
4. Provide continuous protection of system from entry of airborne contamination by proper filtration of air through breathers.
5. During usage, proper oil filling of reservoir and servicing of filters, breathers, reservoirs, etc. cannot be over emphasized.

Sound Level

Noise can be an indication of system problems. Fluid selection and the condition of that fluid in service will affect the noise levels of your systems.

Some of the major factors affecting the fluid conditions that cause the loudest noises in a hydraulic system are:

1. Very high viscosities at start-up temperatures can cause pump noises due to cavitation.
2. Running with moderately high viscosity fluid will impede the release of entrained air. The fluid will not be completely purged of such air in the time it remains in the reservoir before recycling through the system.

3. Aerated fluid can be caused by ingestion of air through the pipe joints of inlet lines, high velocity discharge lines, cylinder rod packings, or by fluid discharging above the fluid level in the reservoir. Air in the fluid will cause abnormal noise and wear in your system.
4. Contamination fluids can cause excessive wear of internal pump parts which may result in increased sound levels.
5. Systems using water based fluids are susceptible to noise created by vaporization of the fluid if excessive vacuums and temperatures are encountered.

Fire Resistant Fluids

Hydraulic systems using fire resistant fluids require special engineering considerations. For applications using fire resistant fluids, consult Vickers Guide to Alternative Fluids, Bulletin 579, for the specific component being used or contact your local Vickers representative for assistance.

Proper design, operation and maintenance of fluid power systems is of paramount importance to obtain the optimum performance of fire resistant fluids such as synthetics, water glycol and water-in-oil emulsion types.

Additionally, you should consult your fluid supplier for specific fluid maintenance and application data on their fluid.

Water Based Fluids

General Data

To assure an effective emulsion or solution, the water should not have excessive hardness or have an acid nature, and it should be distilled or deionized with less than 300 parts per million hardness.

Hard water containing excessive mineral content, such as calcium and iron, may cause deposits in the hydraulic system or result in additive separation or emulsion breaking.

Proper maintenance of water containing fluids requires periodic testing for pH, oil and water concentrations. The pH should be maintained at 8.0-9.5 in accordance with the supplier's recommendation. If the pH number exceeds these limits, discard the fluid. Always use a premixed fluid to replenish the system. The recommended storage or operating temperature range of water containing fluids is 4°C (39°F) to 49°C (120°F), unless otherwise specified by the fluid supplier.

Types Of Water Based Fluids

Invert Emulsions

Invert emulsions are inverted water-in-oil emulsions consisting of a continuous oil phase surrounding finely divided water droplets that are uniformly dispersed throughout the mixture.

Water-Glycol Fluids

Water-glycol fire-resistant fluids are typically water and diethylene glycol mixtures. They have approximately 40% water content.

Oil-In-Water Fluids

Oil-in-water fluids are emulsions of oil and water. When preparing these mixtures, the soluble oil should always be added to the water while maintaining good fluid agitation. The water should never be added to the soluble oil. Do not mix soluble oil brands.

Filters

Many Vickers standard indicating type inlet filters and return line filters are approved with water-based fluid types.

A reduction of predicted life of hydraulic components should be expected when using water-based fluid types.

Synthetic Fluid Type

Phosphate Ester

Phosphate ester type fluids are manufactured from chemically produced esters. These types of fluids require fluorocarbon seals. Consult your fluid supplier for the types of seals which are compatible.

Environmental Hydraulic Oil

If you have equipment that operates in environmentally sensitive areas, you may consider use of more environmentally aware fluids. These fluids perform well in our hydraulic systems but may require extra caution in order not to exceed their performance capabilities.

Hydraulic Fluid And Temperature Recommendations For Mobile Hydraulic Systems

The oil in a hydraulic system serves as the power transmission medium. It is also the system's lubricant and coolant. The selection of proper oil is a requirement for satisfactory system performance and life.

In most cases, use of these recommendations will lead to selection of a suitable oil. However, due to the complex nature of oil formulation, the variety of oils available and peculiarities of individual hydraulic applications, there will be rare instances where an oil selected on the basis of these recommendations may yield unsatisfactory results. Vickers cannot be responsible for such exceptions. In this respect, the customer is encouraged to consult his Vickers representative or a reputable oil company when selecting an oil.

Important Factors In Selecting An Oil

Additives

Hydraulic fluids contain a number of additive agents which materially improve various characteristics of oil for hydraulic systems. These additives are selected to reduce wear, increase chemical stability, inhibit corrosion and depress the pour point.

Antiwear

Pump performance and reliability are directly affected by the antiwear additive formulation contained in the oil. Oils providing a high level of antiwear protection are recommended for optimum performance and long life.

Viscosity

Viscosity is the measure of the fluid's resistance to flow. The oil selected must have proper viscosity to maintain an adequate lubricating film at system operating temperature.

In addition to dynamic lubricating properties, oil must have sufficient body to provide an adequate sealing effect between working parts of pumps, valves, cylinders and motors, but not enough to cause pump cavitation or sluggish valve action. Optimum operating viscosity of the oil should be between 16 cSt (80 SUS) and 40 cSt (180 SUS).

"Viscosity Index" reflects the way viscosity changes with temperature. The smaller the viscosity change, the higher the viscosity

index. The viscosity index of hydraulic system oil should not be less than 90. Multiple viscosity oils, such as SAE 10W-30, incorporate additives to improve viscosity index (polymer thickened). These oils should have a minimum viscosity index of 120. Oils of this type generally exhibit both a temporary and permanent decrease in viscosity due to oil shear encountered in the operating hydraulic system. The actual viscosity can, therefore, be far less in the operating hydraulic system than what is shown in normal oil data. Accordingly, when such oils are selected, it is necessary to use those with high shear stability to insure that viscosity remains within recommended limits while in service.

Chemical Stability

Oxidation and thermal stability are essential characteristics of oils for mobile hydraulic systems. The combination of base stocks and additives should be stable during the expected lifetime of the oil when exposed to the environment of these systems.

Suitable Types Of Oil

Crankcase Oil

Oil having an API letter designation SE, SF, SG or SH per SAE J183. Note that one oil may meet one or more of these designations.

Antiwear Hydraulic Oil

These oils are produced by all major oil suppliers and should consist of good quality base stocks compounded with antiwear, antioxidation, antifoam and antirust additives. These may be petroleum, vegetable or synthetic base oil.

Due to the large number of different antiwear hydraulic oils, it is impossible for Vickers to test its products with all of the available fluids. Because of this, an evaluation procedure was developed for fluid suppliers to establish the suitability of their products for use in Vickers components. Refer to "Pump Test Procedure For Evaluation Of Antiwear Hydraulic Fluids For Mobile Systems", page 20, for details of the 35VQ25 test procedure. It is the responsibility of your oil supplier to assure that their fluids meet Vickers requirements.

Environmental Hydraulic Oil

If you have equipment that operates in environmentally sensitive areas, you may consider use of more environmentally aware fluids. These fluids perform well in our hydraulic systems but may require extra caution in order not to exceed their performance capabilities. For further clarification, refer to Vickers Guide to Alternative Fluids, Bulletin 579.

Other Oils

Certain other types of petroleum oil are suitable if they meet the following provisions:

1. Contain the type and content of antiwear additives found in the above designated crankcase and antiwear hydraulic oils, and have passed the pump tests.
2. Have sufficient chemical stability for mobile hydraulic system service.
3. Meet the viscosity requirements shown in the following tables.

Oil Viscosity Recommendations

Oil Viscosity Recommendations

Crankcase Oils

Hydraulic System Operating Temperature Range ¹	SAE Viscosity Designation
-23°C to 54°C (-10°F to 130°F)	5W, 5W-20, 5W-30
-18°C to 83°C (0°F to 180°F)	10W
-18°C to 99°C (0°F to 210°F)	10W-30, 10W-40
10°C to 99°C (50°F to 210°F)	20-20W

Antiwear Hydraulic Oils

Hydraulic System Operating Temperature Range ¹	ISO Viscosity Grade
-21°C to 60°C (-5°F to 140°F)	22
-15°C to 77°C (5°F to 170°F)	32
-9°C to 88°C (15°F to 190°F)	46
-1°C to 99°C (30°F to 210°F)	68

¹ Temperatures shown are cold (ambient) start-up to maximum operating. During cold start-up, avoid high-speed operation of hydraulic components until the system is warmed up to provide adequate lubrication.

Pump Test Procedure For Evaluation Of Antiwear Fluids For Mobile Systems

Test Pump

35VQ25A-11*20 (Cartridge Kit P/N 413421)

Test Conditions

Speed: 2350-2400 rpm
Outlet Pressure: 205-210 bar gage (2975-3025 psig)
Inlet Pressure: 0-.15 bar gage (0-2 psig) with flooded inlet
Inlet Temperature: 90-96°C (195-205°F)

Operating Mode

Steady-state pressure at above rated conditions for 50 hours. Terminate test if flow degradation exceeds 7.5 L/min (2 gpm) prior to the completion of the 50-hour test. Such terminations are not considered to be failures since this flow degradation can be due to causes other than excessive wear, such as erosion on the side plates resulting from insufficient inlet pressure.

Initial Fluid Condition

Water Content: .075% maximum
Contamination Level: ISO Code 18/16/14 or better particle count. Alternatively, 30 mg/liter maximum gravimetric contamination (using filter membrane of 0.8 micrometer porosity).

Pump Break-In Procedure

1. Increase pump speed to test level and apply 70 bar gage (1000 psig) outlet pressure. When inlet temperature of approximately 50°C (125°F) is achieved, maintain it for elapsed time of 1/2 hour at pressure.
2. Increase pressure to 140 bar gage (2000 psig). When inlet temperature of approximately 80°C (175°F) is achieved, maintain it for elapsed time of 1/2 hour at pressure.

3. Increase pressure to 205-210 bar gage (2975-3025 psig). When temperature stabilizes at 90-96°C (195-205°F), record operating parameters, including flow. Terminate test if flow is below 136 L/min (36 gpm) after five hours of operation. With production tolerances, low flow sometimes occurs while pumping light fluids. This condition tends to increase the wear rate.

Test Duration

Continue operation of the unit for 50 hours total (including break-in time), periodically monitoring operation parameters.

Number Of Cartridges

Evaluation requires a minimum of three pump cartridges. The fluid should not be changed during the total 150-hour test period.

Accept/Reject Guidelines

1. Total weight loss of all vanes from individual cartridge tested should be less than 15 mg (not including intravanes).
2. Weight loss of ring from individual cartridge tested should be less than 75 mg.
3. Regardless of weight loss measurements, the pump parts, especially the rings, should not have evidence of unusual wear or stress in contact areas. There may be instances when unsatisfactory performance is indicated even though the weight loss is low; for example, galling or excessive burning would not show as excessive weight loss but would be unacceptable.

When any one cartridge out of three fails for any reason, two more cartridges should be tested. In this case, four of the five tested cartridges must meet the above accept/reject guidelines.

This procedure is offered only as a fluid screening method. Successful completion of this test does not constitute endorsement or approval of fluids by Vickers.

Test Circuit

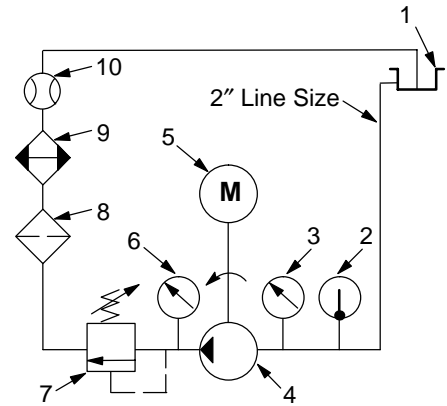

Description of Components

1. Reservoir (50 gallons minimum; elevated above pump centerline to provide gravity feed)
2. Temperature gage or thermocouple
3. Inlet pressure gage
4. Pump: 35VQ25A-11*20 (cartridge kit P/N 413421)
5. Electric motor (125 HP)
6. Outlet pressure gage
7. Pressure relief valve
8. Filter (10 micrometer nominal)
9. Cooler
10. Flow meter

Acceptable Rings



Unacceptable Rings

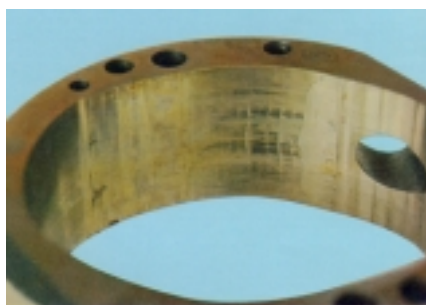

Oil Flow Velocity In Tubing

Oil Flow Capacity Of Tubing

Figures in the chart are USgpm flow capacities of tubing, and were calculated from the formula:
 $GPM = V \times A \div .3208$,
 in which V = velocity of flow in feet per second, and A is inside square inch area of tube.

Figures in Body of Chart are USgpm Flows

Tube O.D.	Wall Thick.	2 Ft/Sec	4 Ft/Sec	10 Ft/Sec	15 Ft/Sec	20 Ft/Sec	30 Ft/Sec
1/2"	.035	.905	1.81	4.52	6.79	9.05	13.6
	.042	.847	1.63	4.23	6.35	6.47	12.7
	.049	.791	1.58	3.95	5.93	7.91	11.9
	.058	.722	1.44	3.61	5.41	7.22	10.8
	.065	.670	1.34	3.35	5.03	6.70	10.1
	.072	.620	1.24	3.10	4.65	6.20	9.30
	.083	.546	1.09	2.73	4.09	5.46	8.16
5/8"	.035	1.51	3.01	7.54	11.3	15.1	22.6
	.042	1.43	2.85	7.16	10.7	14.3	21.4
	.049	1.36	2.72	6.80	10.2	13.6	20.4
	.058	1.27	2.54	6.34	9.51	12.7	19.0
	.065	1.20	2.40	6.00	9.00	12.0	18.0
	.072	1.13	2.26	5.66	8.49	11.3	17.0
	.083	1.03	2.06	5.16	7.73	10.3	15.5
.095	.926	1.85	4.63	6.95	9.26	13.9	
3/4"	.049	2.08	4.17	10.4	15.6	20.8	31.2
	.058	1.97	3.93	14.8	9.84	19.7	29.6
	.065	1.88	3.76	14.1	9.41	18.8	28.2
	.072	1.75	3.51	13.2	8.77	17.5	26.4
	.083	1.67	3.34	12.5	8.35	16.7	25.0
	.095	1.53	3.07	11.5	7.67	15.3	23.0
	.109	1.39	2.77	10.4	6.93	13.9	20.8
7/8"	.049	2.95	5.91	14.8	22.2	29.5	44.3
	.058	2.82	5.64	14.1	21.1	28.2	42.3
	.065	2.72	5.43	13.6	20.4	27.2	40.7
	.072	2.62	5.23	13.1	19.6	26.2	39.2
	.083	2.46	4.92	12.3	18.5	24.6	36.9
	.095	2.30	4.60	11.5	17.2	23.0	34.4
	.109	2.11	4.22	10.6	15.8	21.1	31.7
1"	.049	3.98	7.96	19.9	29.9	39.8	59.7
	.058	3.82	7.65	19.1	28.7	38.2	57.4
	.065	3.70	7.41	18.5	27.8	37.0	55.6
	.072	3.59	7.17	17.9	26.9	35.9	53.8
	.083	3.40	6.81	17.0	25.5	34.0	51.1
	.095	3.21	6.42	16.1	24.1	32.1	48.2
	.109	3.00	6.00	15.0	22.4	29.9	44.9
.120	2.83	5.65	14.1	21.2	28.3	42.4	

Pipe Sizes And Pressure Ratings

Figures in Body of Chart are USgpm Flows

Tube O.D.	Wall Thick.	2 Ft/Sec	4 Ft/Sec	10 Ft/Sec	15 Ft/Sec	20 Ft/Sec	30 Ft/Sec
1-1/4"	.049	6.50	13.0	32.5	48.7	64.9	97.4
	.058	6.29	12.6	31.5	47.2	62.9	94.4
	.065	6.14	12.3	30.7	46.0	61.4	92.1
	.072	6.00	12.0	30.0	44.9	59.9	89.8
	.083	5.75	11.5	28.8	43.1	57.5	86.3
	.095	5.50	11.0	27.5	41.2	55.0	82.5
	.109	5.21	10.4	26.1	39.1	52.1	78.2
	.120	5.00	10.0	25.0	37.4	50.0	74.9
1-1/2"	.065	9.19	18.4	45.9	68.9	91.9	138
	.072	9.00	18.0	45.0	67.5	90.0	135
	.083	8.71	17.4	43.5	65.3	87.1	131
	.095	8.40	16.8	42.0	63.0	84.0	126
	.109	8.04	16.1	40.2	60.3	80.4	121
	.120	7.77	15.5	38.8	58.3	77.7	117
1-3/4"	.065	12.8	25.7	64.2	96.3	128	193
	.072	12.6	25.2	63.1	94.7	126	189
	.083	12.3	24.6	61.4	92.1	123	184
	.095	11.9	23.8	59.6	89.3	119	179
	.109	11.5	23.0	57.4	86.1	115	172
	.120	11.2	22.3	55.8	83.7	112	167
	.134	10.7	21.5	53.7	80.6	107	161
2"	.065	17.1	34.2	85.6	128	171	257
	.072	16.9	33.7	84.3	126	169	253
	.083	16.5	32.9	82.3	123	165	247
	.095	16.0	32.1	80.2	120	160	240
	.109	15.5	31.1	77.7	117	155	233
	.120	15.2	30.3	75.8	114	152	227
	.134	14.7	29.4	73.4	110	147	220

Pipe Sizes And Pressure Ratings

Nominal Pipe Size in.	Outside Diameter of Pipe in.	Number of Threads Per Inch	Length of Effective Threads in.	Schedule 40 (Standard)		Schedule 80 (Extra Heavy)		Schedule 160		Double Extra Heavy	
				Pipe ID-in.	Burst Pres. PSI	Pipe ID-in.	Burst Pres. PSI	Pipe ID-in.	Burst Pres. PSI	Pipe ID-in.	Burst Pres. PSI
1/8	0.405	27	0.26	-	-	-	-	-	-	-	-
1/4	0.540	18	0.40	.364	16,000	.302	22,000	-	-	-	-
3/8	0.675	18	0.41	.493	13,500	.423	19,000	-	-	-	-
1/2	0.840	14	0.53	.622	13,200	.546	17,500	.466	21,000	.252	35,000
3/4	1.050	14	0.55	.824	11,000	.742	15,000	.614	21,000	.434	30,000
1	1.315	11-1/2	0.68	1.049	10,000	.957	13,600	.815	19,000	.599	27,000
1-1/4	1.660	11-1/2	0.71	1.380	8,400	1.278	11,500	1.160	15,000	.896	23,000
1-1/2	1.900	11-1/2	0.72	1.610	7,600	1.500	10,500	1.338	14,800	1.100	21,000
2	2.375	11-1/2	0.76	2.067	6,500	1.939	9,100	1.689	14,500	1.503	19,000
2-1/2	2.875	8	1.14	2.469	7,000	2.323	9,600	2.125	13,000	1.771	18,000
3	3.500	8	1.20	3.068	6,100	2.900	8,500	2.624	12,500	-	-

Preparation Of Pipes, Tubes, And Fittings Before Installation In A Hydraulic System

General Requirements

When installing the various iron and steel pipes, tubes, and fittings of a hydraulic system, it is necessary that they be absolutely clean, free from scale, and all kinds of foreign matter. To attain this end, the following steps should be taken:

- Tubing, pipes and fittings should be brushed with boiler tube wire brush or cleaned with commercial pipe cleaning apparatus. The inside edge of tubing and pipe should be reamed after cutting to remove burrs. Also remove burrs from outside edge.
- Short pieces of pipe and tubing and steel fittings should be sandblasted to remove rust and scale. Sandblasting is a sure and efficient method for short straight pieces and fittings. Sandblasting should not be used however, if there is the slightest possibility that particles of sand will remain in blind holes or pockets in the work after flushing.
- In the case of longer pieces of pipe or short pieces bent to complex shapes where it is not practical to sandblast, the parts should be pickled in a suitable solution until all rust and scale is removed. Preparation for pickling requires thorough degreasing in a recommended vapor degreasing solvent.
- Neutralize pickling solution.
- Rinse parts and prepare for storage.
- Tubing must not be welded, brazed, or silver soldered after assembly as proper cleaning is impossible in such cases. It must be accurately bent and fitted so that it will not be necessary to spring it into place.
- If flange connections are used, flanges must fit squarely on the mounting faces and be secured with screws of the correct length. Screws or stud-nuts must be drawn up evenly to avoid distortion in the valve or pump body.
- Be sure that all openings into the hydraulic system are properly covered to keep out dirt and metal slivers when work such as drilling, tapping, welding, or brazing is being done on or near the unit.

- Threaded fittings should be inspected to prevent metal slivers from the threads getting into the hydraulic system.
- Before filling the system with hydraulic oil, be sure that the hydraulic fluid is as specified and that it is clean. DO NOT use cloth strainers or fluid that has been stored in contaminated containers.
- Use at least a No. 120 mesh screen when filling the reservoir. Use of a Vickers clean cart, porta filtering and transfer unit, is recommended. Operate the system for a short time to eliminate air in the lines. Add hydraulic fluid if necessary.
- Safety precautions. Dangerous chemicals are used in the cleaning and pickling operations to be described. They should be kept only in the proper containers and handled with extreme care.

- Rinse parts in hot water

- Place in tank No. 3. The solution in this tank should contain antirust compounds as recommended by the manufacturer. Usually the parts being treated should be left to dry with antirust solution remaining on them.

If pieces are stored for any period of time, ends of the pipes should be plugged to prevent the entrance of foreign matter. Do not use rags or waste as they will deposit lint on the inside of the tube or pipe. Immediately before using pipes, tubes and fittings should be thoroughly flushed with suitable degreasing solution.

Pickling Process

- Thoroughly degrease parts in degreaser, using a recommended vapor degreasing solvent.
- Tank No. 1 Solution. Use a commercially available derusting compound in solution as recommended by the manufacturer. The solution should not be used at a temperature exceeding that recommended by the manufacturer, otherwise the inhibitor will evaporate and leave a straight acid solution. The length of time the part will be immersed in this solution will depend upon the temperature of the solution and the amount of rust or scale which must be removed. The operator must use good judgement on this point.
- After pickling, rinse parts in cold running water and immerse in tank No. 2. The solution in this tank should be a neutralizer mixed with water in a proportion recommended by the manufacturer. This solution should be used at recommended temperatures and the parts should remain immersed in the solution for the period of time recommended by the manufacturer.

ISO/ANSI Basic Symbols For Fluid Power Equipment And Systems

Lines

Line, Working (Main)	
Line, Pilot (For Control)	
Line, Liquid Drain	
Hydraulic Flow, Direction of Pneumatic	
Lines Crossing	 or
Lines Joining	
Line With Fixed Restriction	
Line, Flexible	
Station, Testing, Measurement or Power Take-Off	
Variable Component (run arrow through symbol at 45°)	
Pressure Compensated Units (arrow parallel to short side of symbol)	
Temperature Cause or Effect	
Vented Reservoir	
Pressurized	
Line, To Reservoir Above Fluid Level	
Below Fluid Level	
Vented Manifold	

Pumps

Hydraulic Pump Fixed Displacement	
Variable Displacement	

Motors and Cylinders

Hydraulic Fixed Displacement	
Variable Displacement	
Cylinder, Single Acting	
Cylinder, Double Acting	
Single End Rod	
Double End Rod	
Adjustable Cushion Advance Only	
Differential Piston	

Miscellaneous Units

Electric Motor	
Accumulator, Spring Loaded	
Accumulator, Gas Charged	

Heater	
Cooler	
Temperature Controller	
Filter, Strainer	
Pressure Switch	
Pressure Indicator	
Temperature Indicator	
Component Enclosure	
Direction of Shaft Rotation (assume arrow on near side of shaft)	

Methods of Operation

Spring	
Manual	
Push Button	

Push-Pull Lever	
Pedal or Treadle	
Mechanical	
Detent	
Pressure Compensated	
Solenoid, Single Winding	
Servo Control	
Pilot Pressure Remote Supply	
Internal Supply	

Flow Control, Adjustable (temperature and pressure compensated)	
Two Position Two Connection	
Two Position Three Connection	
Two Position Four Connection	
Three Position Four Connection	
Two Position In Transition	
Valves Capable Of Infinite Positioning (horizontal bars indicate infinite positioning ability)	

Definition Of Functions

Function	Definition
Intensified Pressure	Pressure in excess of supply pressure which is induced by a booster or intensifier.
Supply Pressure	Power-actuating fluid.
Charging Pressure	Pump-inlet pressure that is higher than atmospheric pressure.
Reduced Pressure	Auxiliary pressure which is lower than supply pressure.
Pilot Pressure	Control-actuating pressure.
Metered Flow	Fluid at controlled flow rate, other than pump delivery.
Exhaust	Return of power and control fluid to reservoir.
Intake	Sub-atmospheric pressure, usually on intake side of pump.
Drain	Return of leakage fluid to reservoir.
Inactive	Fluid which is within the circuit, but which does not serve a functional purpose during the phase being represented.

Valves

Check	
On-Off (manual shut-off)	
Pressure Relief	
Pressure Reducing	
Flow Control, Adjustable-Non-Compensated	

Note

Additional symbols are shown in Vickers Circuitool booklet available for a nominal charge. Ask for circuitool template kit 352.

Color Code For Fluid Power Schematic Drawings

Function	Color
Intensified Pressure	Black
Supply	Red
Charging Pressure	Intermittent Red
Reduced Pressure	Intermittent Red
Pilot Pressure	Intermittent Red
Metered Flow	Yellow
Exhaust	Blue
Intake	Green
Drain	Green
Inactive	Blank

Conversion Factors

To convert		Into		Multiply by
Into		To convert		Divide by
Unit	Symbol	Unit	Symbol	Factor
Atmospheres	Atm	bar	bar	1.013250
BTU/hour	Btu/h	kilowatts	kW	0.293071×10^{-3}
cubic centimeters	cm ³	liters	l	0.001
cubic centimeters	cm ³	milliliters	ml	1.0
cubic feet	ft ³	cubic meters	m ³	0.0283168
cubic feet	ft ³	liters	l	28.3161
cubic inches	in ³	cubic centimeters	cm ³	16.3871
cubic inches	in ³	liters	l	0.0163866
degrees (angle)	°	radians	rad	0.0174533
Fahrenheit	°F	Celsius	°C	$^{\circ}\text{C} = 5 (^{\circ}\text{F} - 32) / 9$
feet	ft	meters	m	0.3048
feet of water	ft H ₂ O	bar	bar	0.0298907
fluid ounces, UK	UK fl oz	cubic centimeters	cm ³	28.413
fluid ounces, US	US fl oz	cubic centimeters	cm ³	29.5735
foot pounds f	ft lbf	joules	J	1.35582
foot pounds/minute	ft lbf/min	watts	W	81.3492
gallons, UK	UK gal	liters	l	4.54596
gallons, US	US gal	liters	l	3.78531
horsepower	hp	kilowatts	kW	0.7457
inches of mercury	in Hg	millibar	mbar	33.8639
inches of water	in H ₂ O	millibar	mbar	2.49089
inches	in	centimeters	cm	2.54
inches	in	millimeters	mm	2.54
kilogram force	kgf	newtons	N	9.80665
kilogram f. meter	kgf m	newton meters	Nm	9.80665
kilogram f. /sq. centimeter	kgf/cm ²	bar	bar	0.980665
kilopascals	kPa	bar	bar	0.01
kiloponds	kp	newtons	N	9.80665
kilopond meters	kp m	newton meters	Nm	9.80665
kiloponds/square centimeter	kp/cm ³	bar	bar	0.980665
metric horsepower		kilowatts	kW	0.735499
microrches	in	microns	m	0.0254
millimeters of mercury	mm Hg	millibar	mbar	1.33322
millimeters of water	mm H ₂ O	millibar	mbar	0.09806
newtons/square centimeter	N/cm ²	bar	bar	0.1
newtons/square meter	N/m ²	bar	bar	10^{-5}

Conversion Factors

To convert \longrightarrow Into \longrightarrow Multiply by

Into \longleftarrow To convert \longleftarrow Divide by

Unit	Symbol	Unit	Symbol	Factor
pascals (newtons/sq meter)	Pa	bar	bar	10^{-5}
pints, UK	UK pt	liters	l	0.568245
pints, US	US liq pt	liters	l	0.473163
pounds (mass)	lb	kilograms	kg	0.4536
pounds/cubic foot	lb/ft ³	kilograms/cubic meter	kg/m ³	16.0185
pounds/cubic inch	lb/in ³	kilograms/cubic centimeter	kg/cm ³	0.0276799
pounds force	lbf	newtons	N	4.44822
pounds f feet	lbf ft	newton meters	Nm	1.35582
pounds f inches	lbf in	newton meters	Nm	0.112985
pounds f/square inch	lbf/in ²	bar	bar	0.06894
revolutions/minute	r/min	radians/second	rad/s	0.104720
square feet	ft ²	square meters	m ²	0.092903
square inches	in ²	square meters	m ²	6.4516×10^{-4}
square inches	in ²	square centimeters	cm ²	6.4516

Hydraulic Formulas

Horsepower:

$$\text{Horsepower} = \frac{\text{GPM} \times \text{PSI}}{1714}$$

Torque:

$$\text{Torque (lb. in.)} = \frac{\text{CU IN./REV.} \times \text{PSI}}{2\pi}$$

$$\text{Torque (lb. in.)} = \frac{\text{HP} \times 63025}{\text{RPM}}$$

Flow:

$$\text{Flow (gpm)} = \frac{\text{CU IN./REV.} \times \text{RPM}}{231}$$

Overall Efficiency:

$$\text{Overall efficiency} = \frac{\text{Output HP}}{\text{Input HP}} \times 100$$

Volumetric Efficiency:

$$\text{Volumetric efficiency (pump)} = \frac{\text{Output GPM}}{\text{Theoretical GPM}} \times 100$$

$$\text{Volumetric efficiency (motor)} = \frac{\text{Theoretical GPM}}{\text{Input GPM}} \times 100$$

Conversion Factors:

1 hp = 33,000 ft. lbs. per minute
 1 hp = 42.4 btu per minute
 1 hp = 0.746 kw/hr (kilowatt hours)

1 U.S. gallon = 231 cubic inches.
 Pipe volume varies as the square of the diameter; volume in gallons = $0.0034 D^2L$

where: D = inside diameter of pipe in inches
 L = length in inches

$$\text{Velocity in feet per second} = \frac{0.408 \times \text{flow (gpm)}}{D^2}$$

where: D = inside diameter of pipe in inches

Atmospheric pressure at sea level = 14.7 PSI

Atmospheric pressure decreases approximately 0.41 PSI for each one thousand feet of elevation up to 23,000 feet

Pressure (PSI) = feet head \times 0.433 \times specific gravity.

Specific gravity of oil is approximately 0.85.

Thermal expansion of oil is approximately 1 cu.in. per 1 gal. per 10°F rise in temperature.