

Created by
FK & CK

Title, Supplementary title
Based on document XXX
Replaces sheet (4/25)

WAR123 000

Rev.	Date of issue	Sheet
A	21.04.2024	4/25

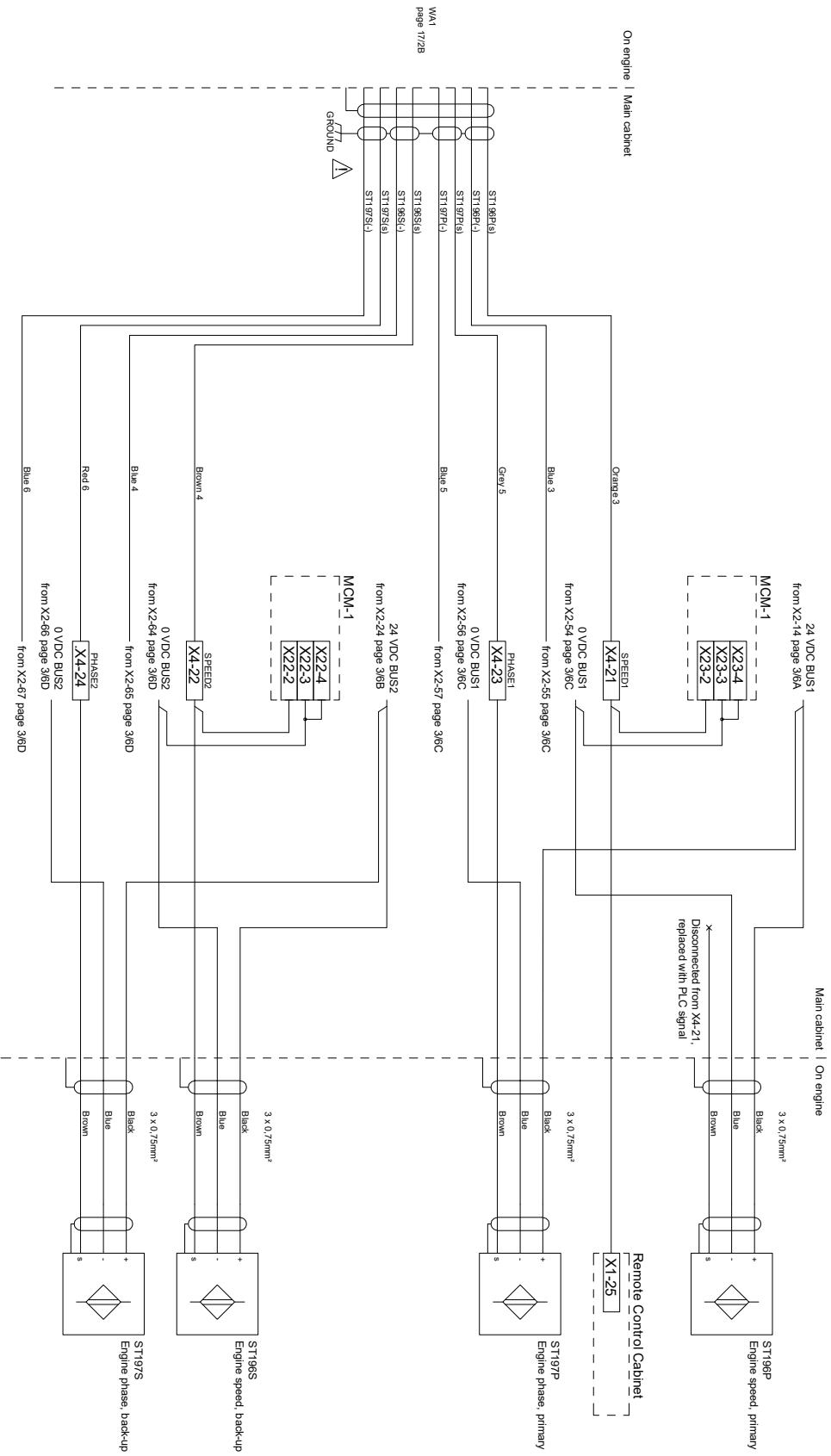

⚠ All ST1986x and ST1976x inner shields to be connected to cabinet ground



Created by
FK & CK

Title, Supplementary title
Based on document XXX
Replaces sheet (5/25)

WAR123 000

Rev.	Date of issue
A	21.04.2024

Sheet
5/25

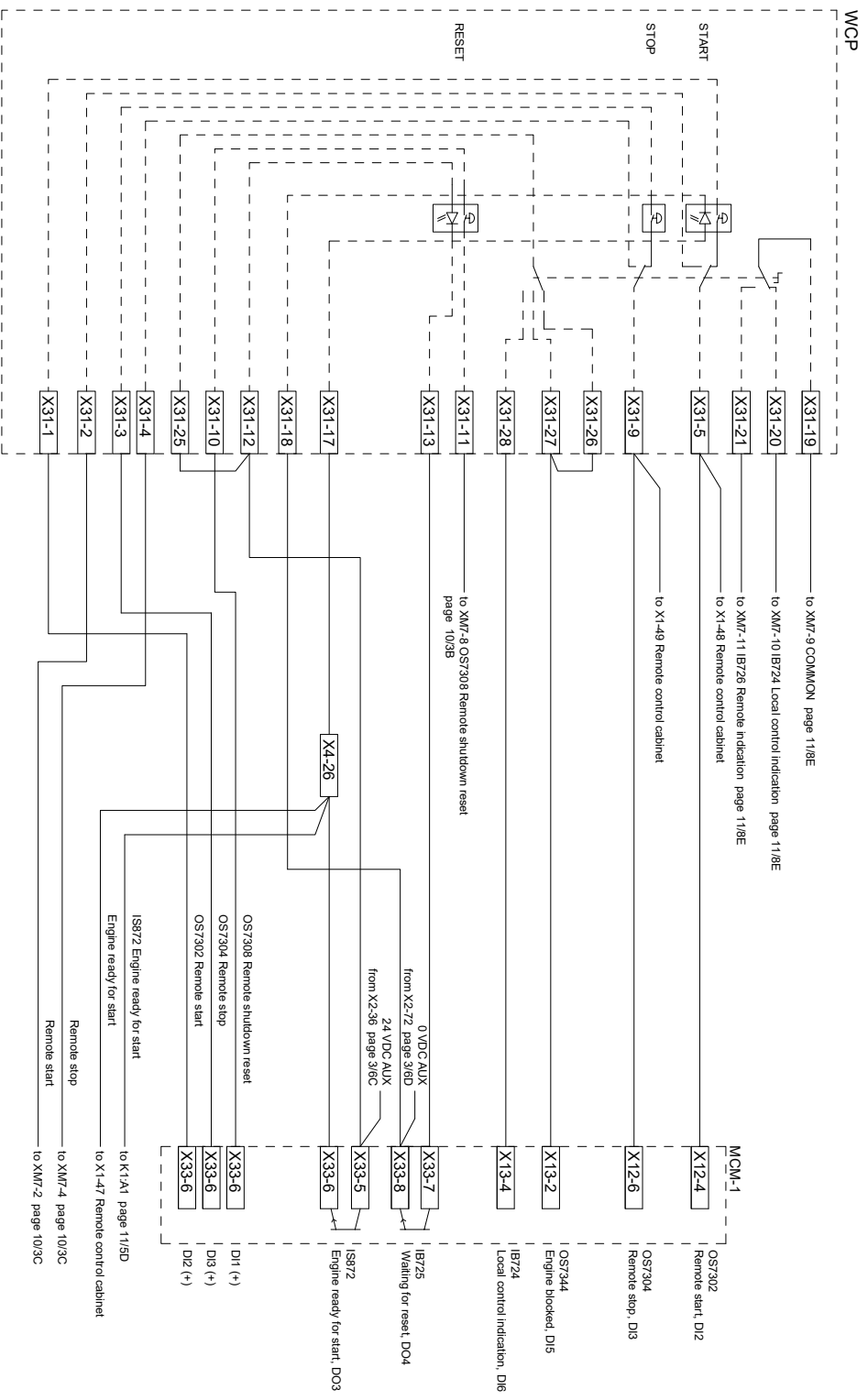

Created by
FK & CK

Title, Supplementary title
Based on document XXX
Replaces sheet (7/25)

WAR123 000

Rev.	Date of issue	Sheet
A	21.04.2024	7/25

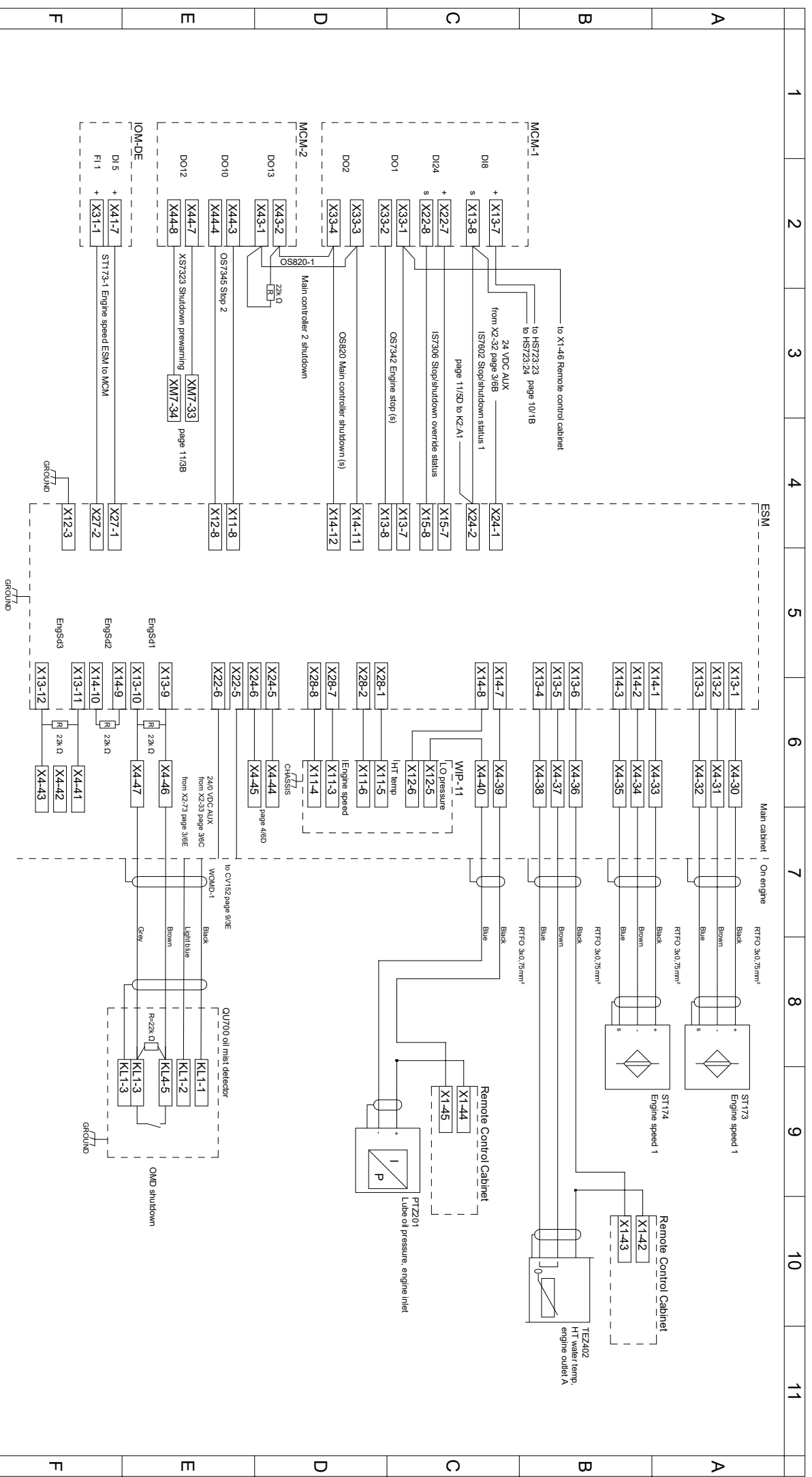

1	2	3	4	5	6	7	8	9	10	11
					Created by FK & CK		Title, Supplementary title Based on document XXX Replaces sheet (8/25)			
						WAR123 000		Rev.	Date of issue	Sheet
								A	21.04.2024	8/25

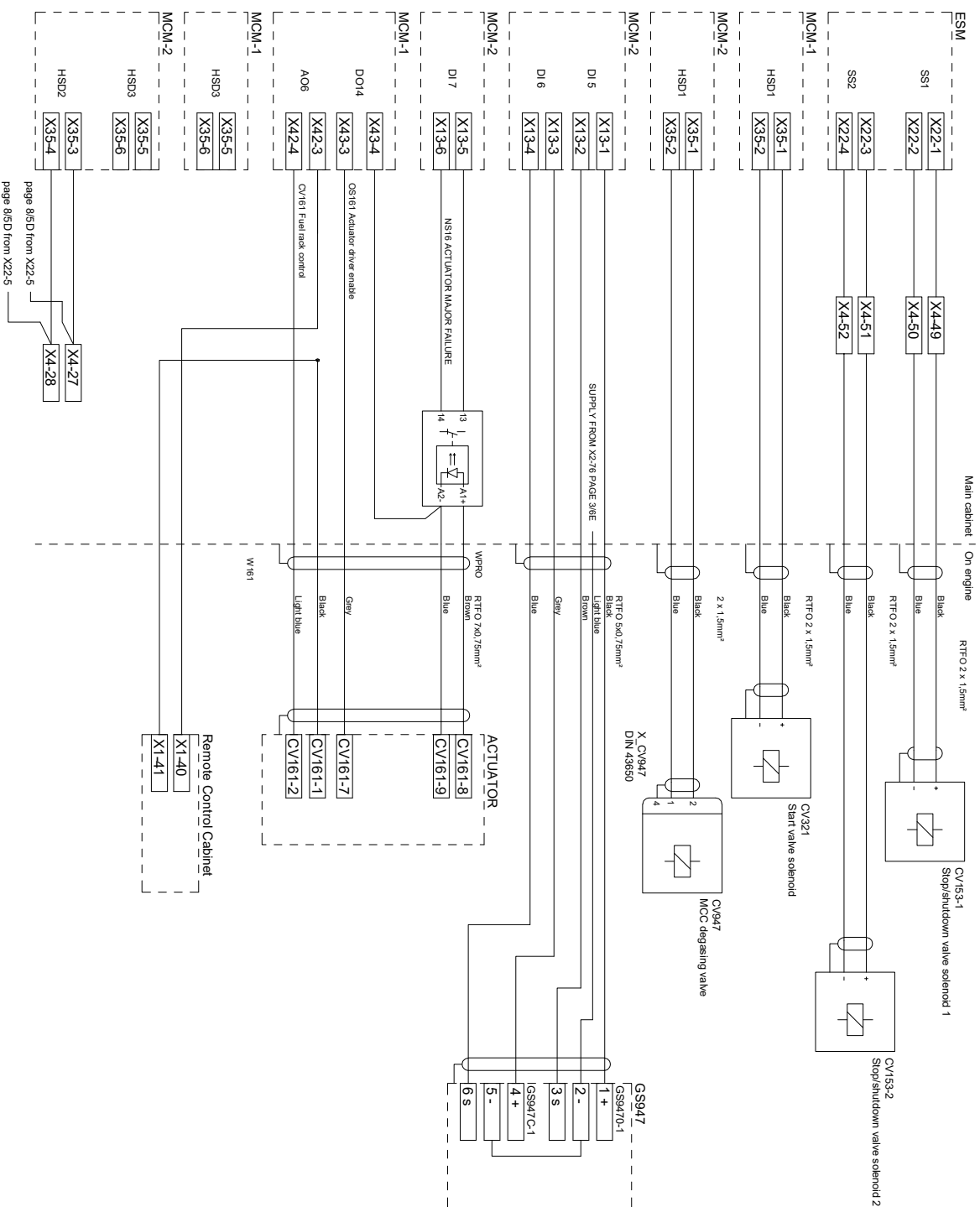

page 8/5D from X22-5
page 9/5D from X22-5



Created by
FK & CK

Title, Supplementary title
Based on document XXX
Replaces sheet (9/25)

WAR123 000

Rev.	Date of issue	Sheet
A	21.04.2024	9/25

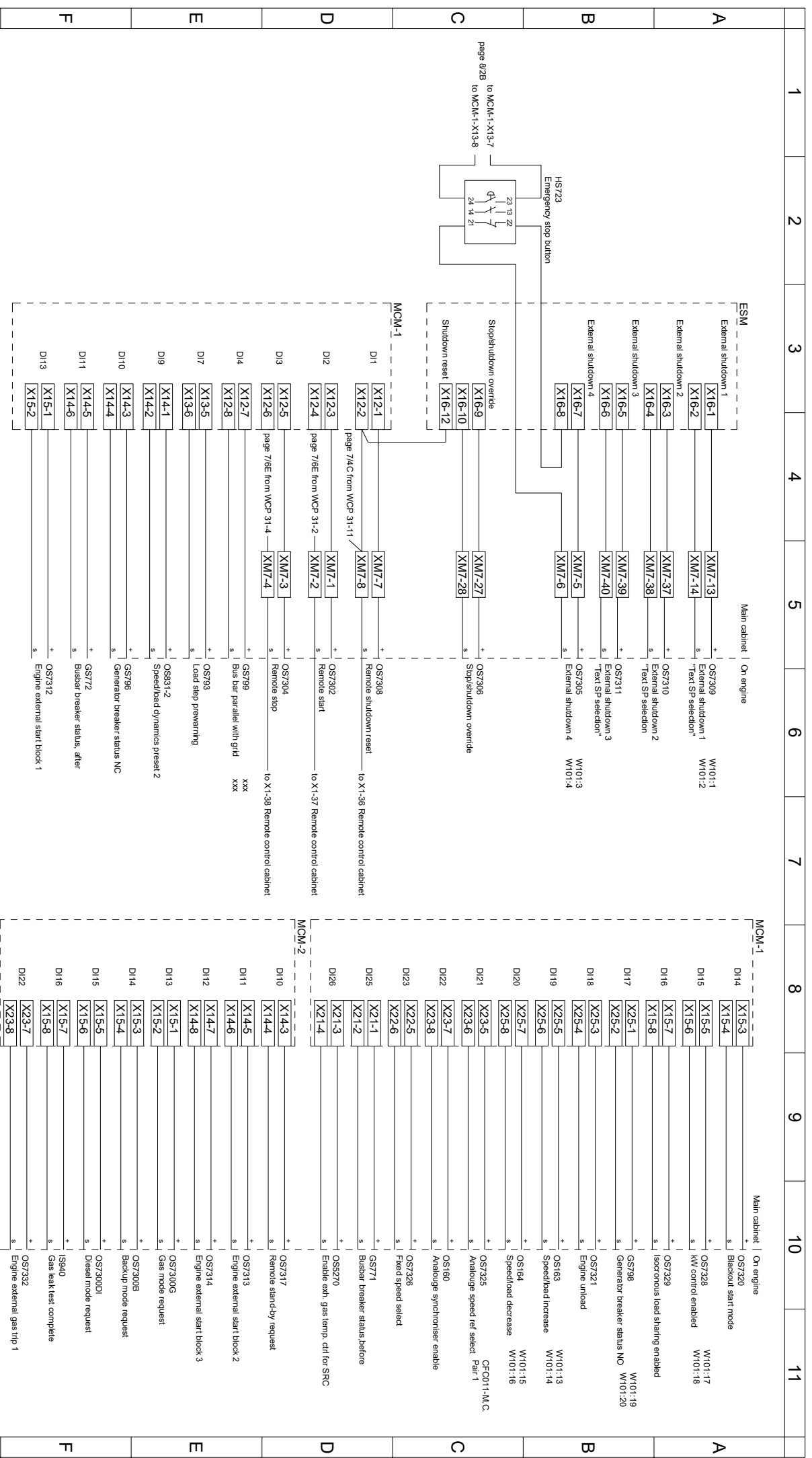

1	2	3	4	5	6	7	8	9	10	11
						Created by FK & CK		Title, Supplementary title Based on document XXX Replaces sheet (10/25)		
				WAR123 000		Rev. A Date of issue 21.04.2024		Sheet 10/25		

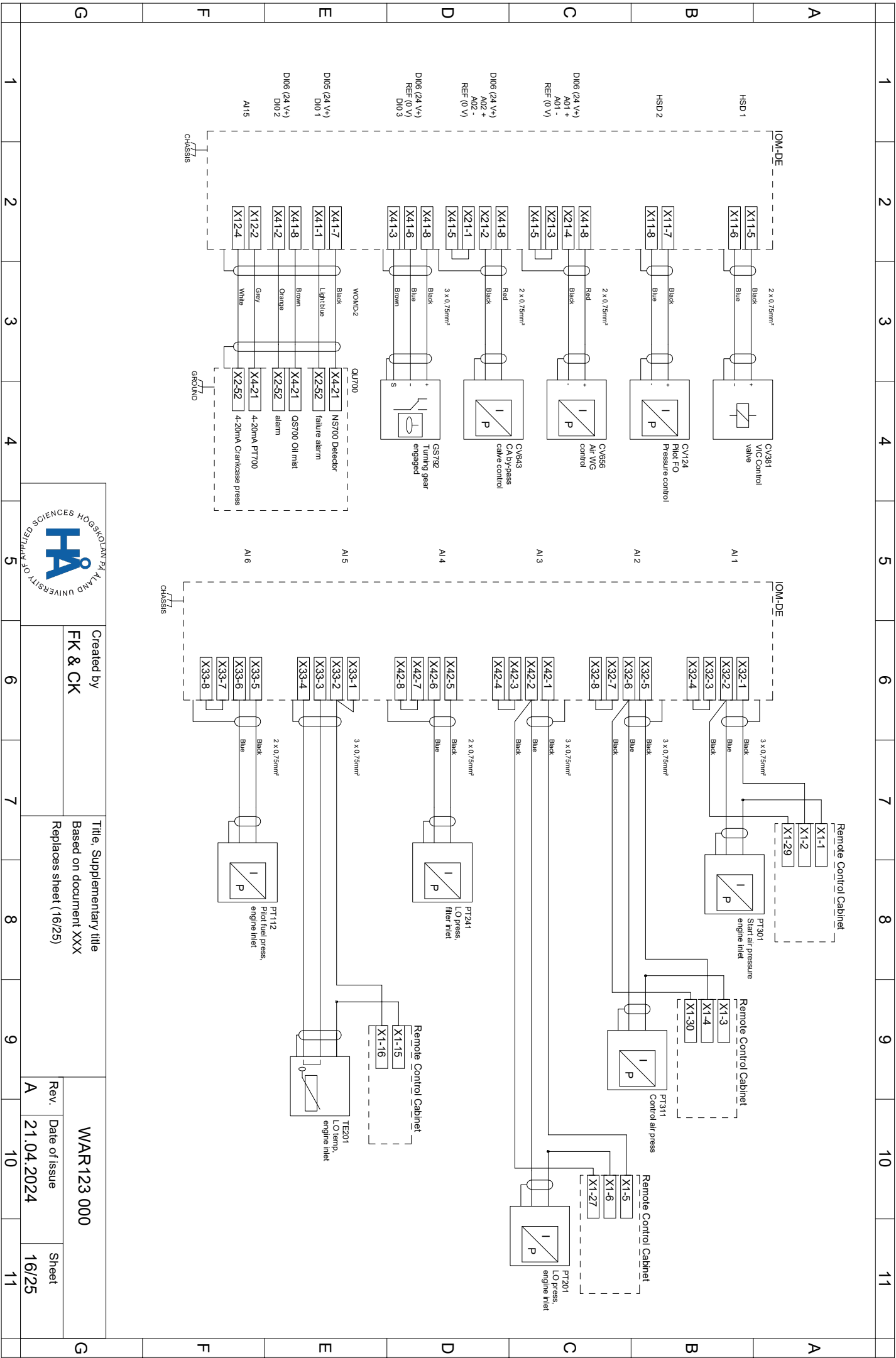

Created by
FK & CK

Title, Supplementary title
Based on document XXX
Replaces sheet (16/25)

WAR123 000

Rev.	Date of issue	Sheet
A	21.04.2024	16/25

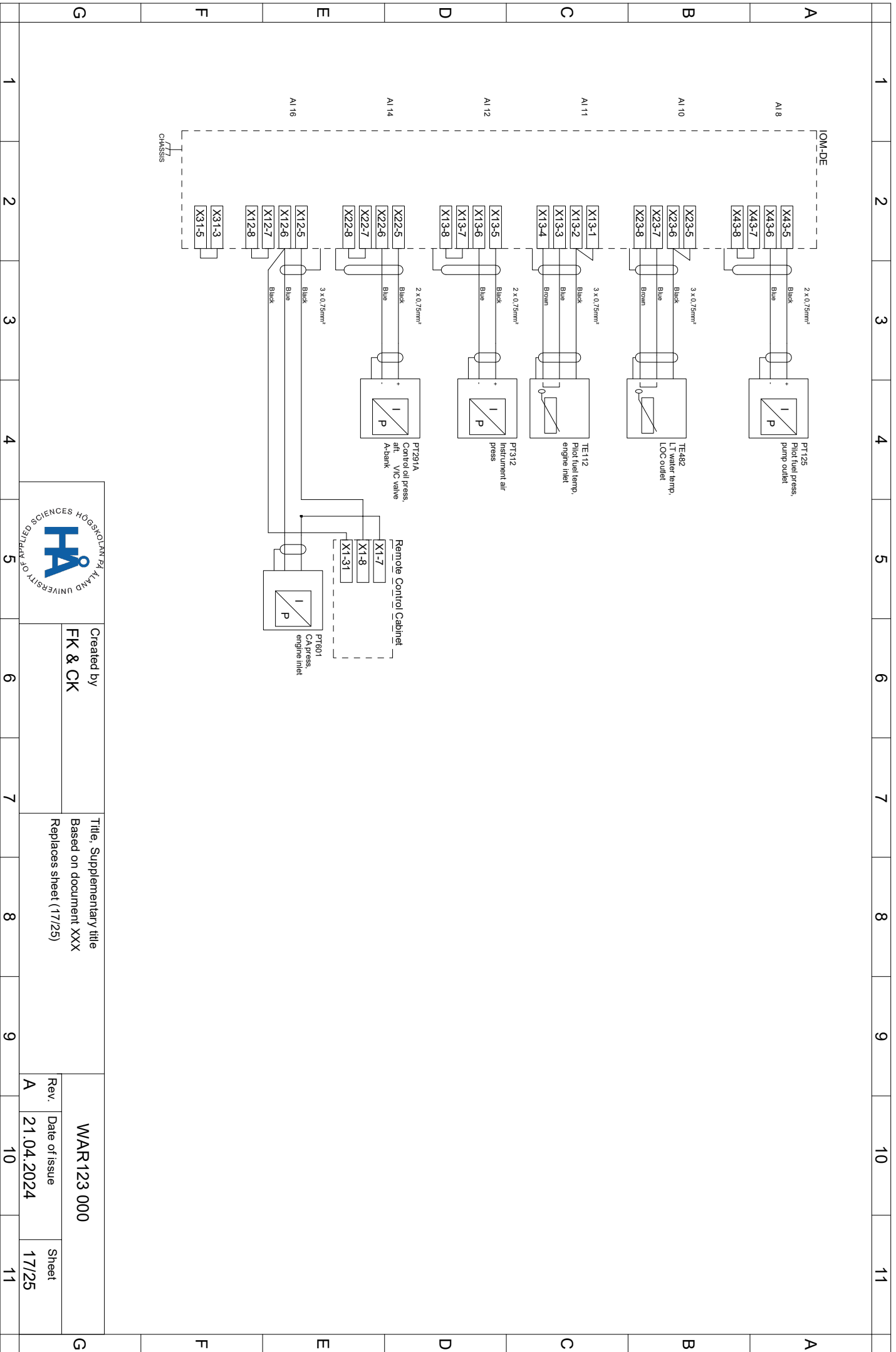

Created by
FK & CK

Title, Supplementary title
Based on document XXX
Replaces sheet (17/25)

WAR123 000

Rev.	Date of issue
A	21.04.2024

Sheet
17/25

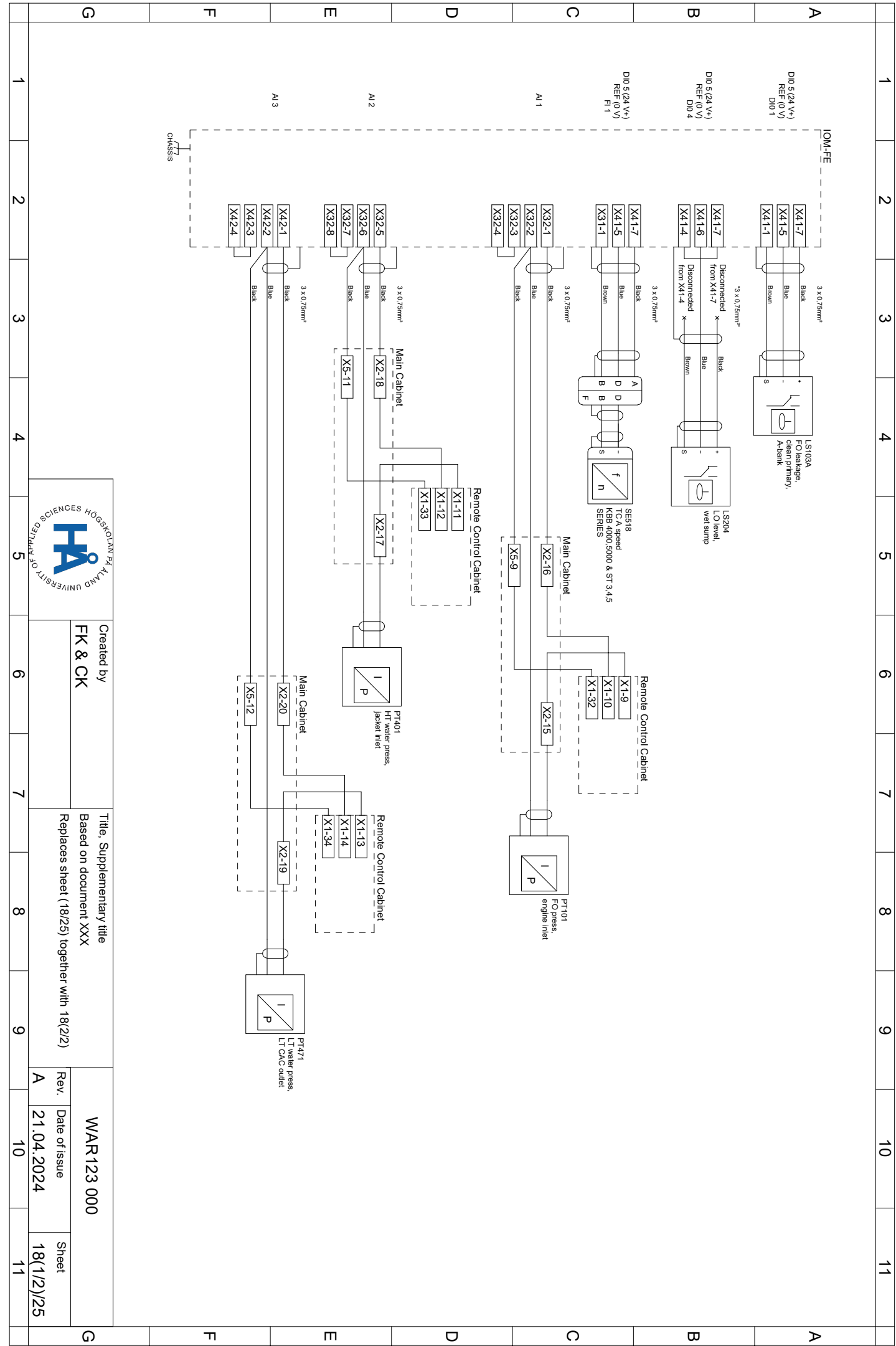

Created by
FK & CK

Title, Supplementary title
Based on document XXX
Replaces sheet (18/25) together with 18(2/2)

WAR123 000

Rev.	Date of issue	Sheet
A	21.04.2024	18(1/2)/25

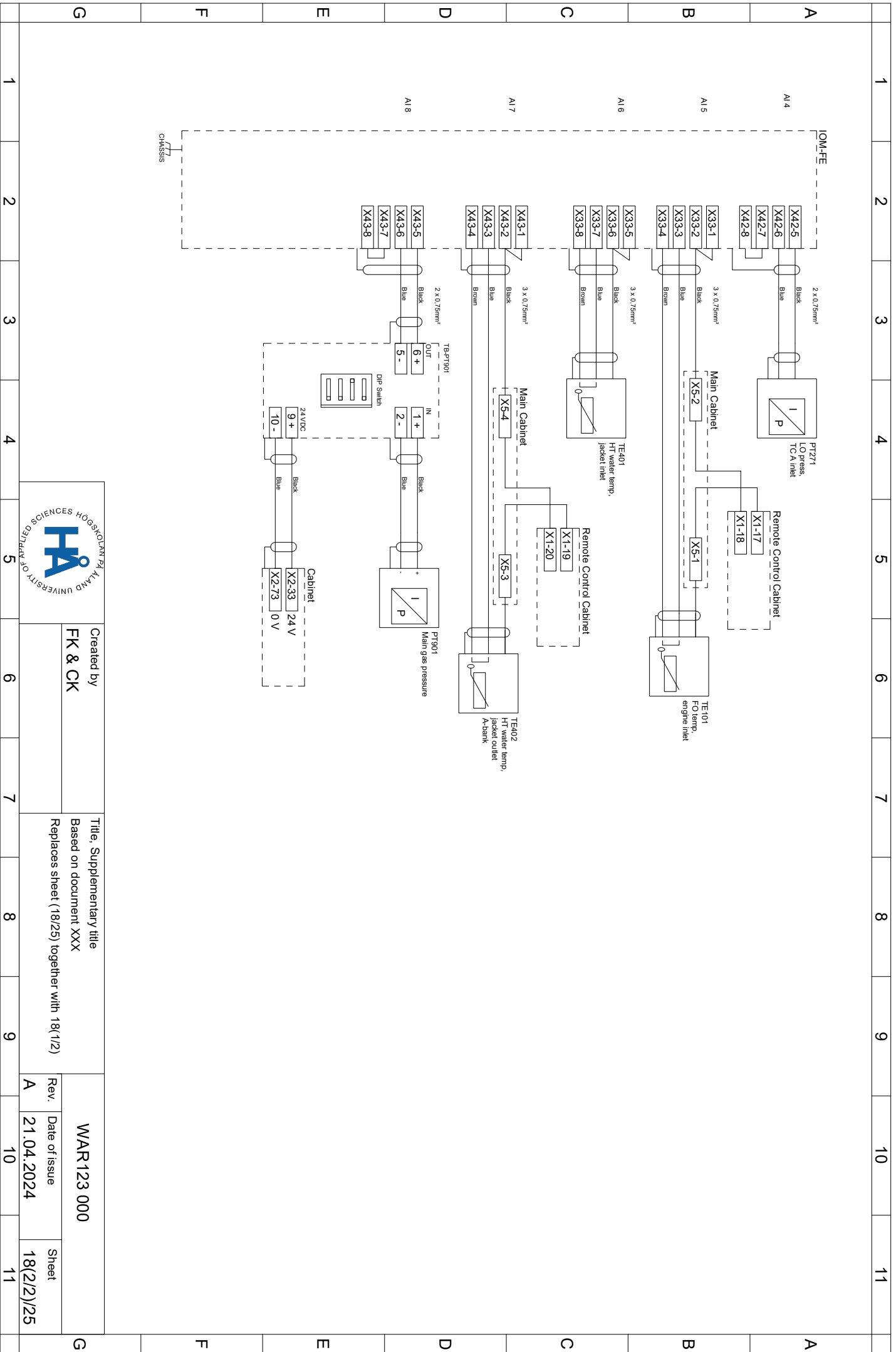

Created by
FK & CK

Title, Supplementary title
Based on document XXX
Replaces sheet (18/25) together with 18(1/2)

WAR123 000

Rev.	Date of issue
A	21.04.2024

Sheet
18(2/2)/25

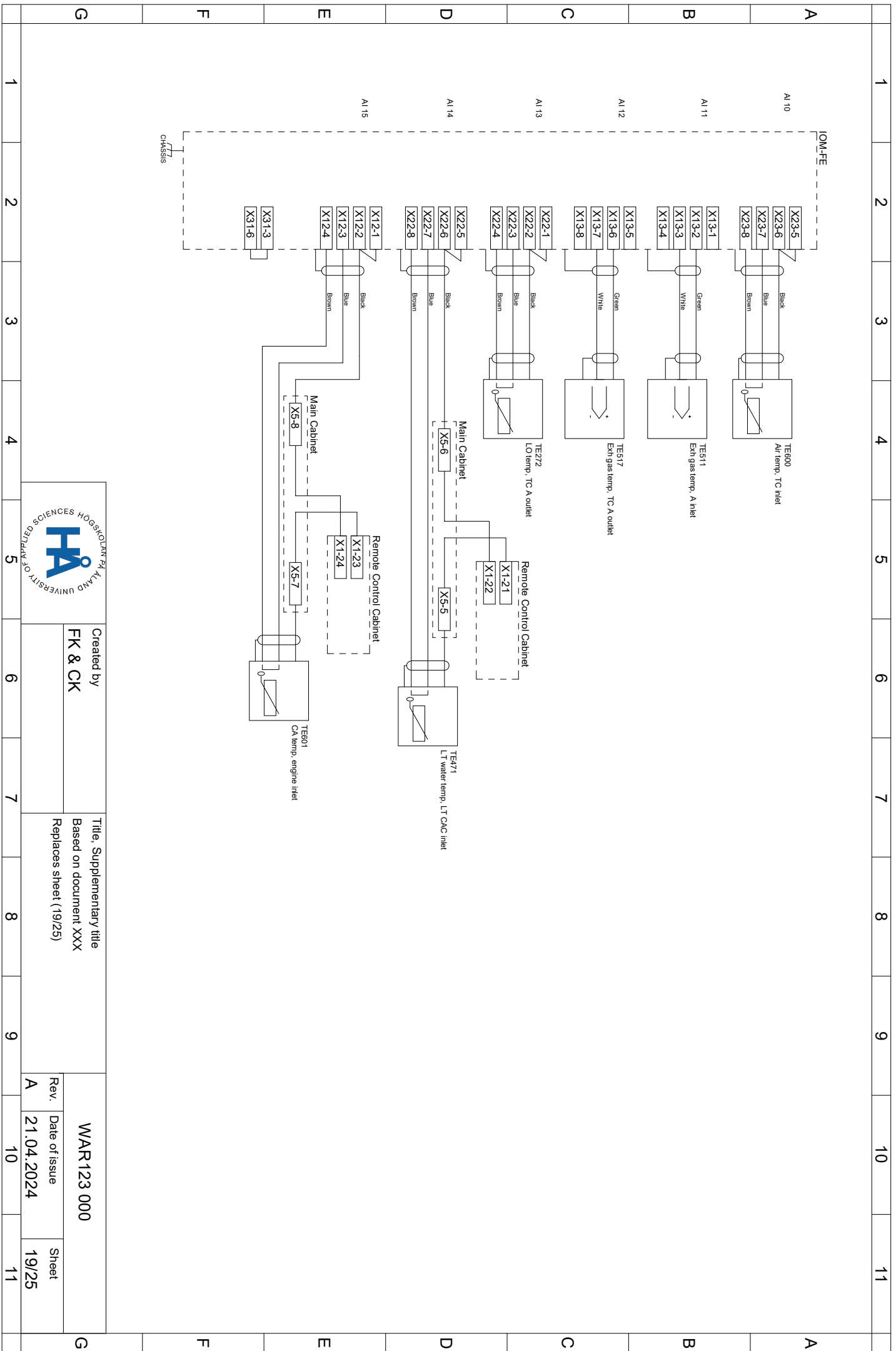

Created by
FK & CK

Title, Supplementary title
Based on document XXX
Replaces sheet (19/25)

WAR123 000

Rev.	Date of issue	Sheet
A	21.04.2024	19/25

1 2 3 4 5 6 7 8 9 10 11

G F E D C B A