

# Designing for Manufacturing on a Desktop FDM 3D Printer: Designing a 3D Printable DIY Ceramics Extruder

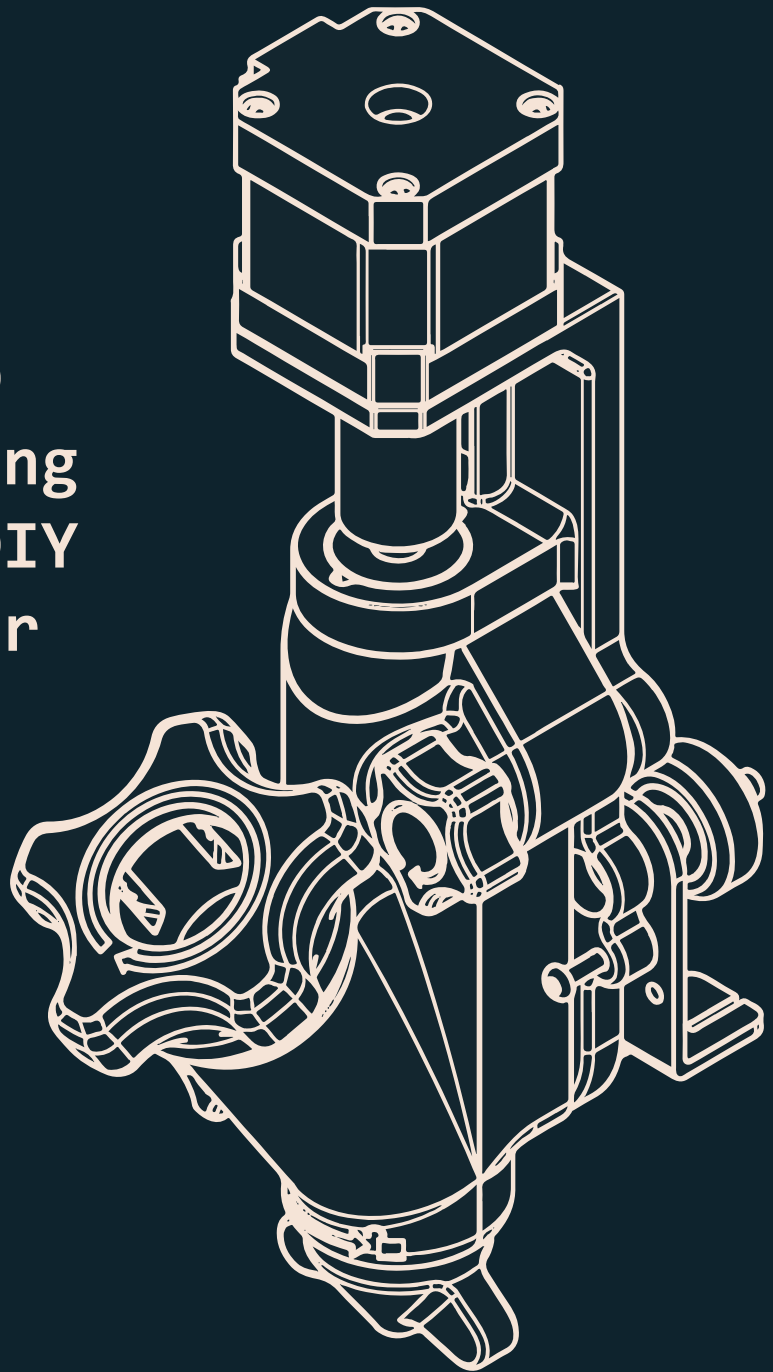

Lilja Nikkilä  
Metropolia UAS  
Industrial Design  
Bachelor of Culture and Arts  
2024

# Abstract

**Author:** Lilja Nikkilä

**Title:** Designing for Manufacturing on a Desktop FDM 3D Printer:  
Designing a 3D Printable DIY Ceramics Extruder

**Number of pages:** 62

**Date:** 29.4.2024

**Degree:** Bachelor of Culture and Arts

**Programme:** Degree Programme in Design

**Major:** Industrial design

**Instructor:** Tuomo Äijälä

**Keywords:** 3D printing, ceramics, design for manufacturing, open source, open design, DIY

This thesis delves into the realm of industrial design, specifically focusing on optimizing designs for desktop FDM 3D printers. The thesis explores strategies aimed at maximizing the benefits of FDM 3D printing. There exists a gap in understanding the unique attributes and potentials of FDM 3D printing, resulting in suboptimal use of the manufacturing method. This thesis highlights the necessity of a shift in mindset regarding the expectations of 3D printers, urging a deeper consideration of why and how parts are manufactured. By acknowledging the specific constraints and potentials in FDM 3D printing, designers can better tailor their designs for FDM printing, thus enhancing outcomes. This thesis emphasizes the importance of considering the capabilities and restrictions of the manufacturing method when it comes to the design process. Overall, this thesis aims to foster a deeper understanding of FDM 3D printing within industrial design practice, urging designers to let the manufacturing method guide the design process, and with it create better designs for manufacturing.

Employing design decisions and workarounds for the design of 3D printed objects allows for no post-processing, making the manufacturing more economical and ecological. It is possible to create professional looking and functional 3D printed products with desktop FDM 3D printers, opening up immense possibilities for users.

# Tiivistelmä

**Tekijä:** Lilja Nikkilä

**Otsikko:** FDM 3D-tulostimelle tuotantoon suunnittelu:

3D-tulostettavan DIY-saviextruderin suunnittelu 3D-tulostimeen

**Sivumäärä:** 62

**Päivämäärä:** 29.4.2024

**Tutkinto:** Muotoilija (AMK)

**Tutkinto-ohjelma:** Muotoilun tutkinto-ohjelma

**Pääaine:** Teollinen Muotoilu

**Ohjaaja:** Tuomo Äijälä

**Asiasanat:** 3D-tulostus, keramiikka, tuotantoon suunnittelu, avoin lähdekoodi, tee-se-itse

Tämä opinnäytetyö sukeltaa teollisen muotoilun maailmaan, keskittyen erityisesti suunnittelun optimointiin FDM 3D-tulostimille. Opinnäytetyö tutkii strategioita, joiden tavoitteena on maksimoida FDM 3D-tulostuksen hyödyt. 3D-tulostimien käyttäjillä on aukko ymmärryksessä FDM 3D-tulostuksen ainutlaatuisista ominaisuuksista ja potentiaaleista, mikä johtaa valmistusmenetelmän puutteelliseen käyttöön. Tämä opinnäytetyö korostaa tarvetta muuttaa ajattelutapaa ja odotuksia 3D-tulostimien suhteen, kehottaen syvempään pohdintaan siitä, miksi ja miten osia valmistetaan. Tunnistamalla FDM 3D-tulostuksen erityiset rajoitteet ja mahdollisuudet suunnittelijat voivat paremmin räätälöidä suunnittelunsa FDM-tulostusta varten, parantaen näin tuloksia. Myös opinnäytetyö tuo ilmi valmistusmenetelmän kykyjen ja rajoitusten huomioimisen tärkeyttä suunnitteluprosessissa. Yleisesti ottaen tämä opinnäytetyö pyrkii syventämään ymmärrystä FDM 3D-tulostuksesta teollisen muotoilun näkökulmasta, kehottaen suunnittelijoita antamaan valmistusmenetelmän ohjata suunnitteluprosessia ja luomaan siten parempia designeja valmistusta varten.

Tarkoituksen mukaisen muotoilun ja vaihtoehtoisten ratkaisujen käyttäminen 3D-tulostettujen esineiden suunnittelussa mahdollistaa tarpeettoman jälkikäsittelyn välttämisen, mikä tekee valmistuksesta taloudellisempaa ja ekologisempaa. FDM 3D-tulostimilla on mahdollista luoda ammattimaisen näköisiä ja toiminnallisia 3D-tulostettuja tuotteita, mahdollistaen suuria mahdollisuuksia käyttäjille.

# Table of Contents

- 01 Introduction
  - 1.1 Research Question
  - 1.2 Goals
- 02 Knowledge Base
  - 2.1 3D Printing
    - 2.1.1 Fused Deposition Modeling (FDM)
    - 2.1.2 3D Printing Ceramics
    - 2.1.3 3D Printing as a Tool for Access
  - 2.2 Community Around 3D Printing
    - 2.2.1 Open Source
    - 2.2.2 Slicers
    - 2.2.3 Open Design
    - 2.2.4 DIY
      - 2.2.4.1 The “Ikea Effect”
  - 2.3 Benchmarking
- 03 Development and Design Process
  - 3.1 Ideation
    - 3.1.1 Settling on an Idea
  - 3.2 Design Drivers
  - 3.3 Designing for Manufacturing on a 3D Printer
    - 3.3.1 Capabilities
    - 3.3.2 Restrictions
    - 3.3.3 Solutions and Workarounds
    - 3.3.4 Potential
  - 3.4 Design Language Led by the Manufacturing Process
  - 3.5 Prototype
  - 3.6 Testing
- 04 End Result
  - 4.1 Iteration, Development and Improvements
- 05 Conclusion and Thoughts
- Sources
- Image Sources



When desktop 3D printers arrived on the market, the average household acquired the capability to create plastic objects comparable to injection molded plastic objects. Communities around 3D printing started to emerge and users started creating masses of 3D models from usable and practical things, to ornamental objects. Different projects were developed by users all over the world, connected through the internet in various sites. The infinitely customisable and configurable possibilities of printing 3D objects gave users the power to customize their own spaces according to their wants and needs. This kind of grandiose attitude is a beautiful idea and a direction to strive for, but the possibilities of desktop 3D printers are still limited. To maximize and optimize the possibilities of FDM 3D printers, we need to understand the capabilities and limitations of the technology.

This thesis explores the possibilities and limitations of desktop FDM 3D printers, and how these aspects steer the overall look and design of printed objects. The means of which these aspects are explored are by designing an open access 3D printable clay extruder for school environments, meant to be used and assembled by students.

The idea of maximizing the 3D printers capabilities and letting that lead the design of the product, has led me to look for and see the flaws and unnecessary in most 3D printed objects on the internet, especially in small businesses that sell 3D printed objects. There are certain conventions and expectations people gravitate towards when it comes to plastic products. Most plastic products in the world nowadays have been manufactured using injection molding. Injection molding as a way of manufacturing has its own limitations that have dictated the design of the products, such as the draft angles on the objects necessary for removing the parts out of its mold. These conventions for design and the capabilities of the manufacturing process are expected of 3D printed products as well. Even though 3D printing and injection molding are very different manufacturing methods. The average desktop FDM 3D printer can not create any shape imaginable, but it comes really close to it. Unnecessary amounts of support materials are commonly used when FDM 3D printing. I believe it can be eliminated with the change of design. The purpose of this thesis is to explore the ways 3D printable objects could be designed to take full advantage of the possibilities and advantages of FDM 3D printing.



Image 1. Ceramic 3D printing has a lot of potentials in many fields of work.

## 1.1 Research Question

How to optimize designs for FDM 3D printer manufacturing and maximize the possible benefits of 3D-printing?

What capabilities, possibilities and limitations are there with FDM 3D printing?

## 1.2

## Goals

The goal in this thesis is to create a DIY clay extruder for a desktop 3D printer. Users can manufacture and source the parts for the extruder themselves, and it is encouraged for them to do so. All the parts that can be printed on a 3D printer are 3D printed out of PLA plastic, which is the most commonly available 3D printer filament material out there, and is very easy to print with. Most of the other parts are possible to be sourced from a common hardware store, from bolts to pneumatic fittings. The parts and part sizes are standardized. The instructions and bill of material is freely available on the internet under an open source license. The printer is designed to be used in a school environment, to encourage students to familiarize, learn and experiment with clay 3D printing. Also other aspects to strive for are the ease of use and ease of understanding the extruder, and for the overall cost to stay relatively affordable.

02

Knowledge

Base

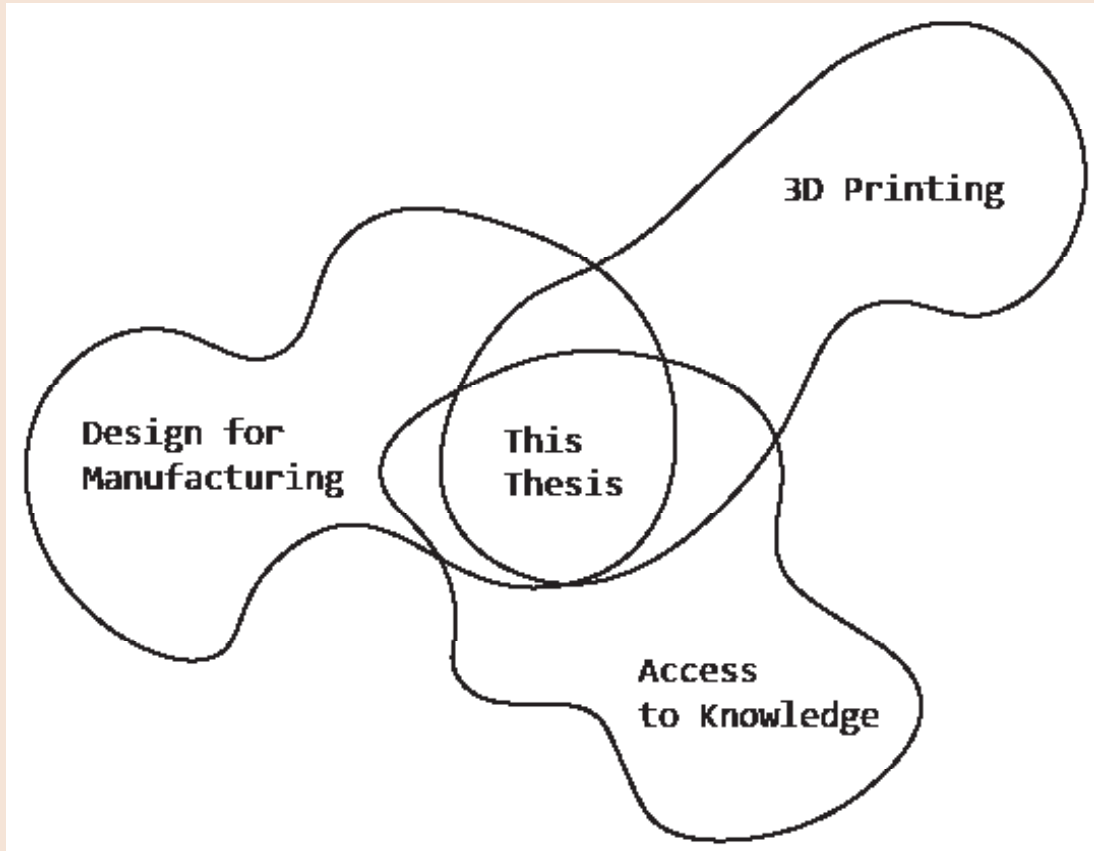

Frame of reference

## 2.1

## 3D

## printing

3D printing or additive manufacturing is fabrication of digital 3D objects using machines controlled by computers, commonly known as 3D printers. The concept of a 3D printer was first found in science fiction. The earliest mention of something resembling the printers of today is in a 1945 short story by William Fitzgerald Jenkins titled “Things pass by”. The story described a machine that created objects from magnetronic plastic. (Protolabs 2023). The first 3D printer patents were filed in 1970 for a process called liquid metal recorder by Johannes F. Gottwald and in the 1980 Dr. Hideo Kodama expanded on the idea proposing the use of thermosetting polymers. In 1986, Charles Hull patented SLA (Stereolithography) and later his company released the first commercially available 3D printer, the SLA-1. (Protolabs 2023)

The commercialization of 3D printers, the accessibility of them and the community built around them has brought in a wave of startups, projects and products that were developed at a small scale and utilized 3D printing. The printer that the first modern desktop 3D printers are based on was a community designed and built 3D printer that was supposed to be able to print and duplicate itself (RepRap 2023).

The RepRap project, short for Replicating Rapid Prototyper, was launched in 2005 by Adrian Bowyer. The goal of the project was to develop a machine that could build most of its own parts, making such technology much more accessible and affordable. The RepRap 1.0 Darwin machine, which could do what Adrian envisioned for the project, could build several of its own parts for assembly. (Protolabs 2023). This kind of accessible thinking behind these early community projects have opened up the possibility for more users to use 3D printing technology, and have been the root for most Desktop 3D printers, and community websites related to 3D printing.

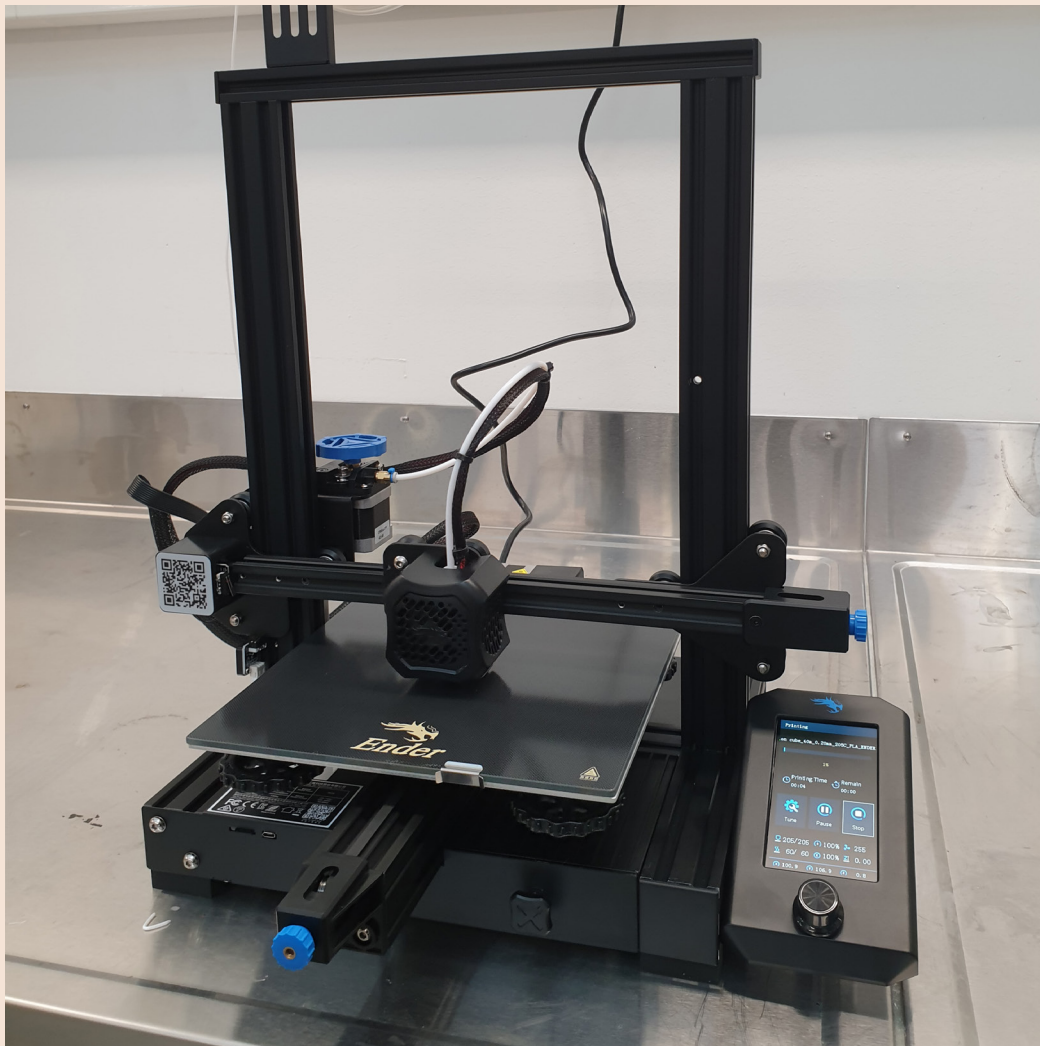
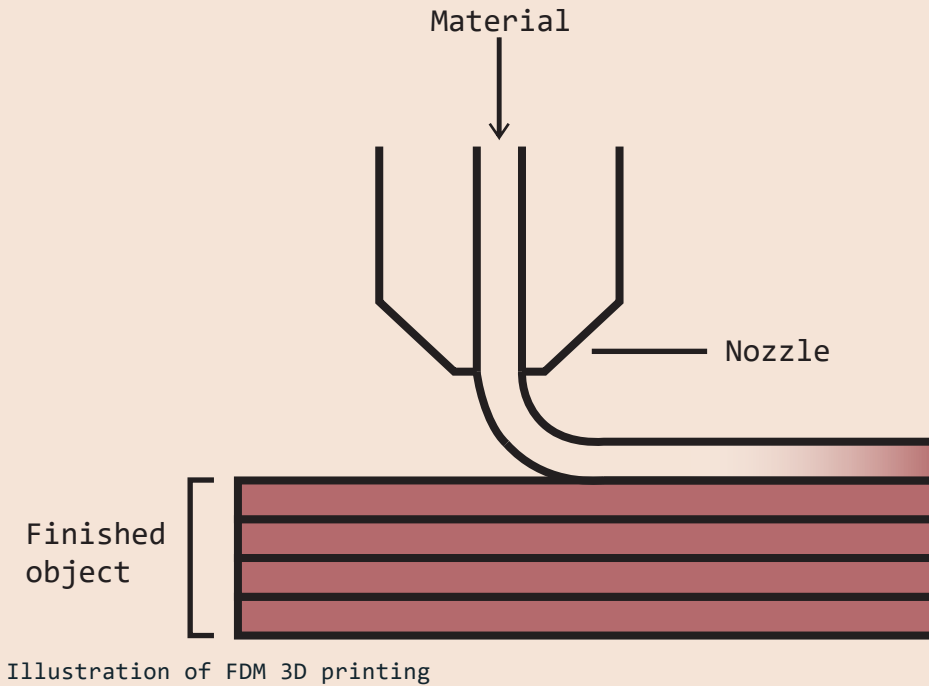

Image 2. A lot of the hobbyists FDM 3D printers are based off of the source code and design of the RepRap project.



The open design concept, as demonstrated in the RepRap project, revolutionized the software industry and is poised to revolutionize the product design industry as well (Kadushin 2010). The accessibility is not seen only on the average consumer scale but also in high education research fields. Research based practices have utilized 3D printing for very specific tasks and machines. The potential cost and time to acquire machines for highly specific tasks is overcome by using accessible and cheap 3D printers and open source hardware. (Głażewska 2020)

Nowadays 3D models created by amateurs to professionals can be found on the internet, the majority in open access and some for a small fee. The 3D models can be downloaded for free on sites like Thingiverse.com or Printable.com. Small businesses and startups have emerged and been able to manufacture items at a small scale with the help of additive manufacturing. Communities around products and 3D printers have developed, where the users develop parts and add-ons to the products for specific tasks or specific needs. One of the most well known modern desktop 3D printer brands is called Prusa Research, or more commonly as Prusa. Prusa was a startup founded by Josef Průša and has grown to be one of the most recognizable 3D printer brands known in the 3D printing space. Prusa has all the plastic parts on their “i3” printer 3D printed using FDM printers, they also give out the 3D models for the parts to download and print for free if parts on your Prusa printer have broken or you might want to print the parts for yourself. This practice of 3D printable parts on their machines “upholds the original idea of the Reprap project” (Prusa Research. n.d.).



### 2.1.1 Fused Deposition Modeling (FDM)

There are many types of 3D printers in the world, but most desktop 3D printers are known as Fused Deposition Modeling (FMD) printers. FDM is the most favored 3D printing method according to the 2023 Trend Report by Protolabs (Protolabs 2023). Fused Deposition Modeling is an additive manufacturing method most commonly used in the desktop 3D printers available today, where material is pushed through a nozzle to create 3D objects layer by layer. Most commonly FDM uses thermoplastics in the form of a filament. The most commonly available filament material is PLA plastic. The accessibility, reasonable efficiency, simplicity and popularity of FDM makes it the most used additive manufacturing method of today (Carolo 2024). FDM 3D printing has been widely applied in many fields, especially in ones where rapid prototyping, rapid testing and highly specific custom objects are needed in a short span of time. FDM 3D printing has restrictions in its manufacturing capabilities that other forms of additive manufacturing may not have.



Image 3. Clay 3D printing in progress, posted on Thingiverse by the user Lauhaus.

### 2.1.2 3D printing Ceramics

To be able to 3D print with clay there is a need for a specialized printer capable of extruding clay material. The way the clay could be extruded differs, but the most common way is with pneumatics or a motor driven auger or piston. (Lawless 2023) Clay printing has much different physics and limitations than the conventional FDM 3D printer. Compared to most 3D printer plastics, clay takes a lot longer to dry and acquire a hard and rigid state, where it can maintain its own shape and hold its own weight. These different attributes should be considered when designing a print for a clay 3D printer. Ceramic 3D prints tend to have a need to be post-processed, i.e. dried and then fired in a kiln.

Ceramic 3D printing has a lot of innovative and new applications. It has been adapted in the medical field and the construction industry (Lawless 2023). The properties of ceramics make them great thermal insulators and their hardness and wear resistance open potential use cases in the space industry as well (Abdelkader, Petrik, Nestler, Fijalkowski 2024).

Jonathan Keep (2020, 3) states in the “A Guide to Clay 3D printing” published 2020 that ceramic 3D printing will not overshadow traditional ceramics work. In the future 3D printing will just be considered to be a part of the ceramic tradition (Keep 2020, 3).

### **2.1.3 3D Printing as a Tool for Access**

3D printing has opened the ability for the average consumer to create highly customizable, rather durable plastic objects. With only a 200€ printer and filament you can potentially create more value than originally invested. Compared to the time, effort and money it takes to find some plastic objects, e.g. a replacement part for a stand, the traditional way would be time consuming and costly, and possibly impossible if such replacement parts are not available, or in production.

The customizability of 3D printed objects serve as a great tool for highly personal needs, such as for disabled people. Everyone's needs are different and unique, but with 3D printing there is a potential to create gadgets, tools and objects to help people with their totally unique needs and requirements.

## 2.2 Community Around 3D Printing

The original RepRap printers were community designed and created. The same phenomenon has carried over to the modern day mainstream 3D printing scene. The 3D printing scene has been shaped by a combination of counterculture and institutional support. Fordyce, Heemsbergen, Mignone and Nansen (2015) suggest in their publication about 3D printer makerspaces and related counterculture communities that: “The social practice of 3D printing arises from a twin tradition of industrial design and countercultural garage-workshops.” (Fordyce, Heemsbergen, Mignone, Nansen. 2015, 192). The communities that have developed around 3D printing are inherently open and communally contributory. Hackerspaces and peer-to-peer learning communities have been a big part of the world of 3D printing, and such spaces for product development have been the antithesis of many other successful technological advancements, e.g. the Homebrew Computer Club that was integral in the development of the Apple computer (Fordyce, Heemsbergen, Mignone, Nansen. 2015, 192). After the expiration of many patents related to 3D printing, filed in the 1980s, everything was released to the public domain, many regarding Fused Deposition Modeling also known as Fused Filament Fabrication (Ultimaker n.d.). The release of many patents opened up the access for communities-turned-companies to develop and profit on these technologies, rather than only large corporations (Fordyce, Heemsbergen, Mignone, Nansen. 2015, 192). Sentiments for the desire for an easy communal peer-based 3D model/STL sharing platform was expressed in the 2015 survey done for the publication by Fordyce, Heemsbergen, Mignone and Nansen (Fordyce, Heemsbergen, Mignone, Nansen. 2015). Today there are a number of peer-to-peer sharing platforms on the internet. The open communal aspect of 3D printing has been a driving factor in the development and current day space of 3D printing.

### 2.2.1

### Open

### Source

Open source is a term for code that is open and accessible to anyone to inspect, modify and enhance. Open source code is made available, unlike other code most commonly under the control of a company. Open source is usually created and maintained by decentralized contributors, often as just a hobby (Kuznetsov, Paulos 2010. 296). The world as we know it today has been molded with open source and it has been a huge driver of innovation. The original software for the web servers used in our daily lives are based on open source software. (Opensource.com. n.d. ) Linux, an open source operating system, powers approximately over 65% of the world's internet servers (Głażewska 2020). Opensource.com proposes for people to approach life in “the open source way” in all aspects of life, not only in software. “Expressing a willingness to share, collaborating with others in ways that are transparent (so that others can watch and join too), embracing failure as a means of improving, and expecting—even encouraging—everyone else to do the same.” (Opensource.com. n.d.).

Many different types of open source licenses are available that allow for the licensed content to be used, shared and modified freely. Some allow even commercial use of the content, as long as original creators and sources for the content are credited.

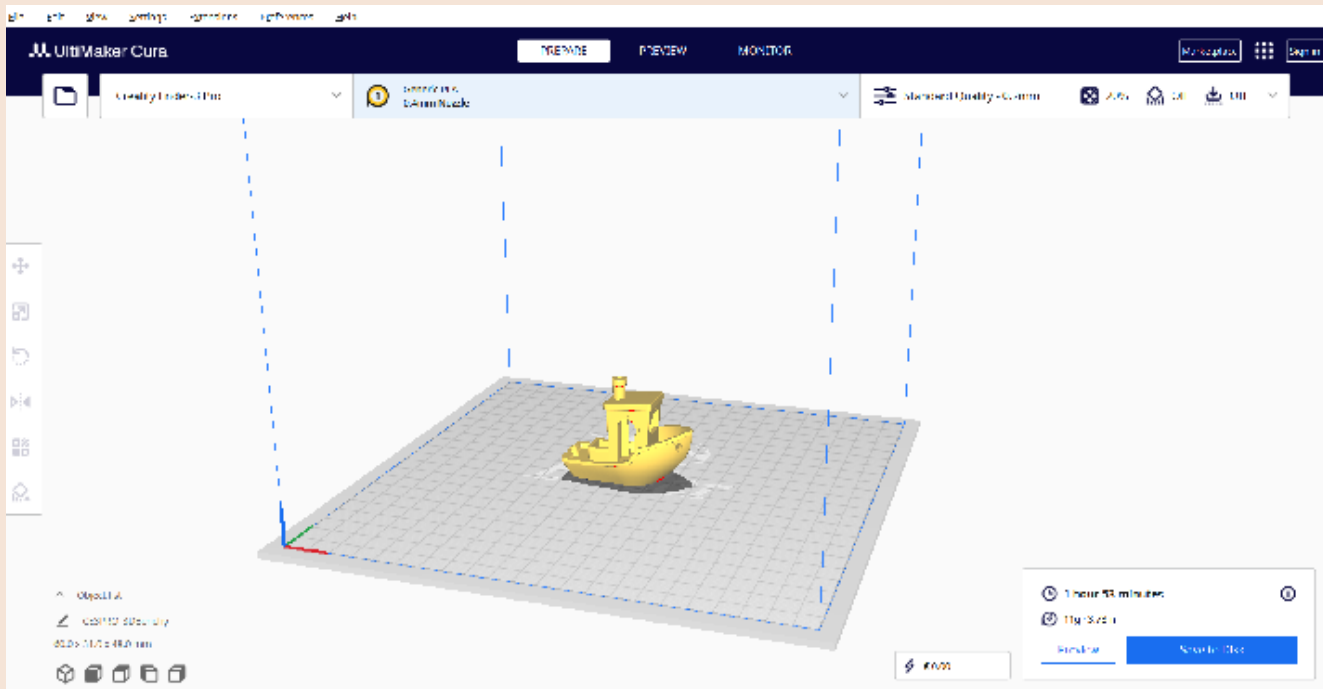

Image 4. A screenshot of the Ultimaker Cura slicer.

### 2.2.2

## Slicers

Slicers are the processing softwares that make commands based on 3D models that most common FDM 3D printers use to do the printing operations, like movement and amount of extrusion. Many of the most used slicers for FDM 3D printers are open source or are based on open source software. Prusa maintains their slicer called PrusaSlicer. PrusaSlicer is an advanced fork of the open source slicer called Slic3r (Wikipedia n.d.). The most known slicer in the hobbyist space is called Cura, which was created by David Braam who was later employed by Ultimaker, a community-turned-company. Cura is maintained by Ultimaker. (Wikipedia n.d.) There are many other slicers available, a considerable portion of them derived from existing open source slicers.

### 2.2.3

## Open

## Design

Open design, derived from open source, differs from the accessibility of code and software. Instead, the emphasis of open design is on making the design processes, resources and outcome openly available for collaboration and improvement. The evolution of product design and development is inevitable due to the internet's disruptive nature and the easy access to CNC machines (Kadushin 2010), such as the 3D printer. Maybe open design will one day see such prevalence like open source does in Linux.

### 2.2.4

## DIY

Humans have always relied on the ability to create and repurpose. People have repaired clothes, tools and houses by themselves without relying on professionals for ages. A core value in do-It-Yourself (DIY) is self-reliance. "Modern societies oppose the principle of self-reliance with mass- production and consumer economy. Tangible things can be bought. Professionals can be hired to build and repair. Artists can be employed to decorate or customize." (Kuznetsov, Paulos 2010. 295). DIY is much more communal now than before. Over the years DIY has evolved to be a more relevant phenomenon and has gained popularity through social networks and online sharing tools (Kuznetsov, Paulos 2010. 295). The peer learning of open source and makerspaces are rooted in the DIY culture. People who interact with DIY communities often share projects, ask questions and gain inspiration for their own works. In the study done by Kuznetsov and Paulos (2010) they highlight four themes that differentiate DIY communities from other well studied communities. The themes are: Low barrier of entry, learning, creativity and open sharing. These are the same themes that can now be witnessed in the 3D printing community today



### 2.2.4.1 The “IKEA Effect”

The “Ikea effect” is a phenomenon named after the Swedish furniture and household store chain Ikea. The phenomenon describes how people who have created or participated in the creation process of a product tend to value the price of the product way higher than a product they have not been a part of creating. The self imbued value comes from the feeling of competence and the feeling of being in control when successfully constructing products, even though the users are not really in control, for they are following assembly instructions. (Norton, Mochon, Ariely. 2011. 18). The willingness to pay more is subconscious rather than conscious behavior. When asked if people are willing to pay more for pre-assembled products compared to products that they have to assemble themselves, people say they would pay more for pre-assembled products. So the “Ikea effect” is an retrospective effect, the value of the product is perceived more highly after it has been assembled by the user. (Norton, Mochon, Ariely. 2011. 20).

When it comes to DIY projects to experience the “Ikea effect”, the end result must be a success. Otherwise, the perceived value could be lower than an end result achieved through struggle and trial and error. The “Ikea effect” comes from the feeling of competence. (Norton, Mochon, Ariely 2012) An argument could be made that the mere existence of the free to access materials of open source projects is not enough for some users to achieve fulfillment through DIY projects, for they might not feel competent to carry out some projects. Some projects may have concepts not understood and require skills not commonly held by most of possible users. Therefore, making the accessible material easily understandable and approachable, could be the way to allow more access to technologies and possibilities otherwise unavailable because of financial constraints or limited availability. Proper instructions and clear documentation is a great way to provide fulfillment through DIY projects.

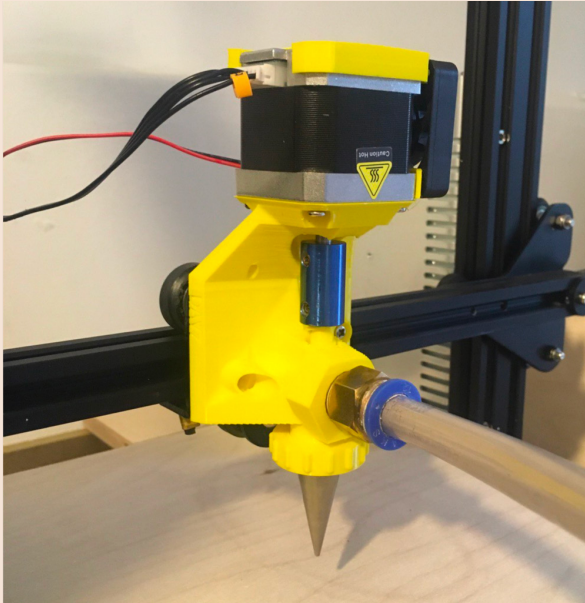

Image 5. Clay extruder attached on to an Ender 3 printer posted by davidsfeir.

### “Paste extruder for ender 3 (de-airing)”

Posted on Thingiverse August 15, 2023  
by the user: d a v i d s f e i r

The extruder is very affordable and the design of it is very simple and effective. Minimal amount of 3D printed parts are needed, and the parts are relatively small in size, making it a very light extruder. The extruder uses a cake decorators nozzle as the extruder nozzle. The cooling fan of the original hot end of the 3D printer is used to cool the motor. An auger is 3D printed, which allows for a custom auger profile.

### “Bricoleur Clay Extruder, Open Source”

Posted on Thingiverse March 14, 2016  
by the user: L a u h a u s

The extruder is approximately the same price as the first extruder. Consisting of only two 3D printed parts, it is very easy to make. For the auger, the extruder uses a wood screw, making intricate and small prints possible, when also making it really affordable. The container for the clay is not contained in the instructions and downloadable files. However, the way in which the container is mounted on to the 3D printer, as seen in the image, is a really clever solution.

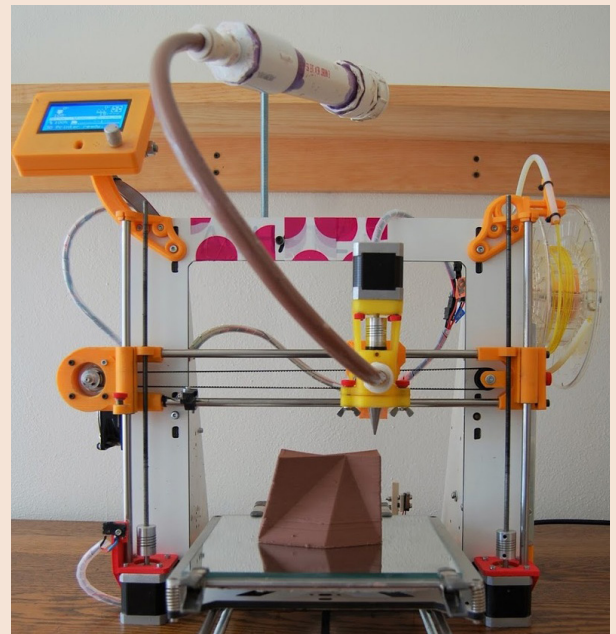

Image 6. Custom clay 3D printer posted on Thingiverse by Lauhaus.



Image 7. A extruder utilizing empty silicon gun cartridges and bicycle spokes.

## “Cheap de-airing clay extruder”

Posted on Thingiverse March 25, 2021  
by the user: [P i o t r W a s n i o w s k i](#)

Piotr’s extruder is a great sleek looking assembly, with the container for the clay attached right on to the extruder. There are around ten 3D printed parts in the full assembly. The extruder uses pressured air and an auger. Piotr says that because of the auger’s proportions it removes air from the clay. The solution for the clay container is very clever, using an empty silicon gun cartridge and bicycle spokes.

## “CERA-1 Clay 3D Printer Extruder”

Posted on Thingiverse March 31, 2020  
by the user: [B r y a n C e r a](#)

Cera-1 is a clay extruder designed by Bryan Cera. It is designed to be mounted on a custom 3D printer. It uses a piston to push the clay out of the container into an auger which pushes the clay through the nozzle. The capacity of clay is huge. Attaching this extruder to the x-carriage of a regular desktop FDM printer, would likely not work. The extruder has a simple and an effective design.



Image 8. A render of the extruder designed by Bryan Cera.

### **03 Development and Design Process**

The development and design process of this extruder did not follow a clear path. First, ideas were quickly tested for validity by creating minimal tests and prototypes, before the final direction for the thesis was found. Once an idea was settled on, sourcing of parts and 3D modeling could begin. Secondly, designs were made inside of a 3D modeling software so quick editing and implementation could be done. New parts could be 3D printed and tested ensuring a swift turnaround time.

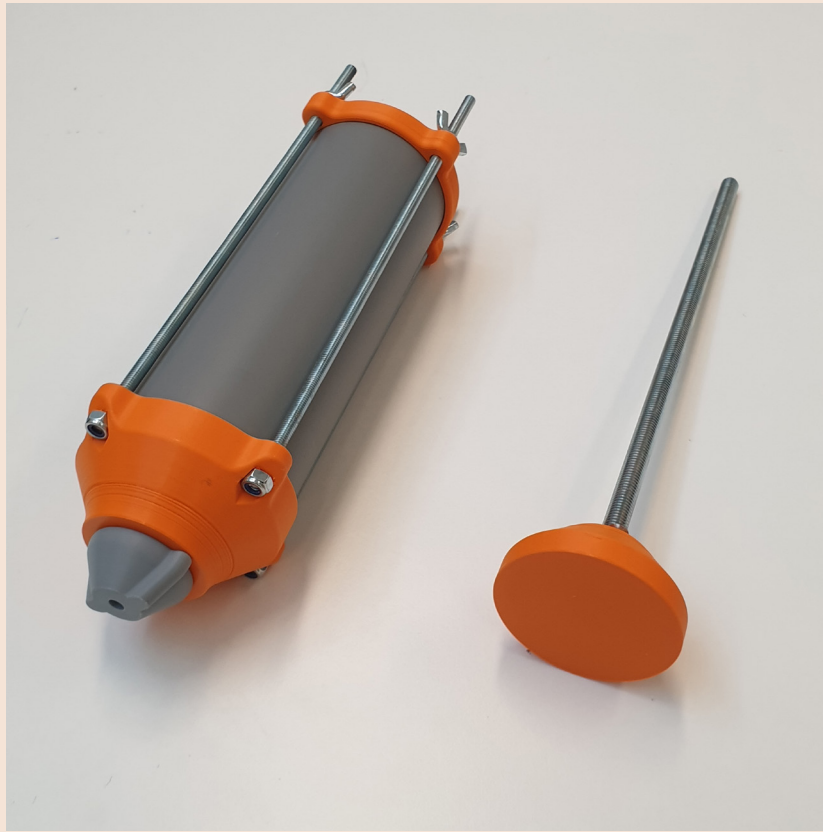

Image 9. A clay extruder made of 3D printed parts, sewage pipe and threaded rod.

### 3.1

### Ideation

The ideation began by bouncing around concepts for the extruder, and for a specific direction I wanted to take the project into. First I played with the idea to make the extruder as cheap as possible, with really cheap hardware store components e.g. sewage pipe. It would have been a rather cheap extruder but there were obstacles that the early designs could not handle. The first idea was to use a plunger type system where the reservoir for the clay was attached straight to the 3D printer's x-carriage with a nozzle on the bottom of the reservoir. The weight of the clay and potential differences in motor strengths became a concern, so the idea was scrapped. In hindsight, the idea of attaching the container straight on to the x-carriage could be possible and it has been done before, but the capacity should be reduced for the weight and the power to be sufficient. The small capacity of the clay was unappealing to me.

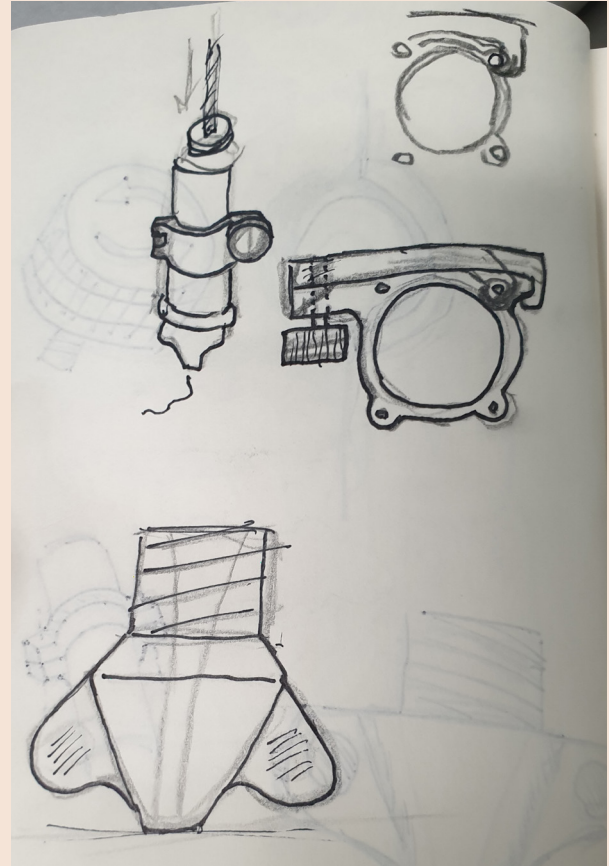

Image 10 and 11. Crude sketches of the parts and assemblies.





Image 12. The first test piece was repurposed for the second idea.



Image 13. Testing of the weight driven system.

The second idea aimed to push the concept of making the machine as financially accessible as possible to its limits. Biggest hurdle that I recognized, after deciding to relocate the heavy clay container off of the printer's x-carriage, was that there was a need for constant pressure to push the clay through a tube into the nozzle of the machine. A really simple solution for pushing the clay to the nozzle was pressurized air, but the cost of pressured air compressors was not that financially accessible. I was driven to come up with a really cheap and accessible solution for that problem. I imagined that a gravity and weight powered piston mechanism could be a possible solution. Weights would be an easy and possibly really cheap way to get power on the machine, and gravity would be a constant source of push. The roadblock with this idea occurred when a length of tube was added to the end of the piston, for it to push the clay through it. The amount of weight it would need was exceeding the amount that the construction could withstand safely. In addition, the complexity of the contraption and it not being particularly user friendly drove me away from the idea, so the idea was scrapped.

### 3.1.1 Settling on an Idea

After struggling with the first two ideas, I made the decision to move away from the idea of making the cheapest possible extruder and try to focus my efforts in a different direction. This is when I decided that the extruder that I was to design was meant for a school environment. The extruder being designed for a school environment would exclude the need to make it extremely affordable. However, affordable components would be preferable for other reasons. The means of power for pushing the clay that I ended up going with was pressurized air. Reasoning was that schools and their workshops would likely have pressurized air systems, or money for compressors. Designing the extruder for students opens up an interesting aspect of making the extruder as user friendly as possible. Creating it as a DIY kit for students to assemble, would encourage them to get to know the machine, the technology and the technique of clay 3D printing. 3D printed parts would be easy to print, and the parts being 3D printed would open the possibility to experiment without the fear of breaking expensive machinery. The users could just print a new part if the old one broke, or modify the 3D model for their liking. The extruder could fit on a lot of 3D printers with just a little modification of the attachment bracket onto the 3D printer's x-carriages. Most of the sketching and ideation of the new version were done along with 3D modeling.



## 3.2 Design Drivers

- Minimal amount of parts
- As many of the parts as possible are 3D printed
- Relatively cheap and easy to source parts
- Easy to use
- Easy to take apart for clean up
- 3D printed parts optimized for manufacturing on a 3D printer
- Fits on an available 3D-printer

### **3.3 Designing for Manufacturing on a 3D Printer**

There are a lot of aspects to consider when designing parts to be manufactured on a 3D printer. While 3D printers have the capability to create nearly anything, the possible post-processing costs and time per part, may sky rocket the price. Over time, the time will add up, especially in large quantity manufacturing. The restriction of 3D prints come from the material properties and the method of manufacturing. The possibilities come from the way additive manufacturing differs from other types of manufacturing. Potentially you can create geometries that other more common ways of manufacturing could never achieve, or could with great difficulty. The advantages of additive manufacturing compared to other ways is complexity of parts, customization and volume of production (Pereira, Kennedy, Potgieter. 2019).

### 3.3.1

## Capabilities

Using additive manufacturing, complex and difficult geometries can quickly be created with only one machine. Compared to traditional methods of manufacturing some geometries might be impossible to achieve and might require many large and expensive machines. Also there is the ability to eliminate fusing parts together by printing the assembly in one (Pereira, Kennedy, Potgieter. 2019).

When optimizing for manufacturing on a FDM 3D printer there are a few different sides to consider. First the design of the product and secondly the production. To optimize the design of the product for 3D printing, you have to know the limits of your FDM printer. Some may be pushed to more extremes but for this thesis we are designing the parts to fit into the basic abilities of a standard desktop FDM 3D printer.

FDM 3D printers can potentially use the same amount of material as the final product has in weight. That means that there is potentially zero waste created during this process. This advantage of FDM 3D printing is often lost on users, for they make up for the shortcomings of the printer with excessive amounts of support material. So creating shapes that negate the need for support material is a great way to optimize for 3D printers potentials. With creating geometries that cover for the need for supports, the design and look of the final product may be different than originally imagined. When designing objects for 3D printing, the designers should allow the manufacturing process to guide the design of the final product, similar to how injection molding influenced the designs of its time. Rather than emulating existing plastic products or other manufacturing methods, we should embrace both the unique capabilities of 3D printing and the distinctive appearance and properties of 3D printed parts.



Image 14. Demonstration of overhang in the article “Overhang overview” by Alexander Ahren.

Overhang is a common thing to consider when designing for FDM 3D printing. Often the threshold for successful overhang is around maximum of  $50\text{-}55^\circ$ . When the geometry exceeds  $55^\circ$ , the material tends to not have enough of the lower layer beneath the printed area to support the molten plastic, so it sags, and when cooled could warp. So keeping integral overhanging geometries to a maximum of  $55^\circ$  is a way to make sure the print is successful consistently and comes out looking good. A  $90^\circ$  overhang, meaning a flat floating bottom surface, is possible in specific scenarios. It is possible only when the floating surface is supported from both ends. This is called bridging. Bridging can be done only when there is a straight shot to the other supporting geometry. The bridge cannot create curved moves, for it has nothing to stick onto and keep its curved shape. The extruded plastic will be pulled tight when it meets the other support, leaving the bridged part straight not curved. There are ways of using bridging to make some geometries come out cleaner, and potentially making “floating” holes into countersink geometries possible.

The orientation of the print is a big thing to consider as well. Some geometries are hard or impossible to be printed cleanly in a certain orientation because of the layer by layer way of printing. So placing certain critical geometries strategically in different places and orientations may allow you to print very complex parts as well. Round details, threads and holes are best printed vertically, so the quality stays consistent and threads working.

When designing strong parts the layer direction must be considered. Vertically printed thin structures are prone to breaking off because of how the layer lines are going crosswise to the height of the print. The small surface area of the layers on layers gives poor layer adhesion making them weak points in the prints. 3D prints are weakest along the horizontal axis parallel to the printed layers. To make strong thin parts the parts need to be printed horizontally. In the horizontal direction the layers are the strongest, because there is more surface area between layers and the plastic is much more resilient in the axis across the layers parallel to the print bed.

Merging parts to be printed as one print is a capability of 3D printing, but all of the aspects and restrictions of FDM 3D printers should be considered, e.g. the orientation and the aspect of parts breaking and wearing. Parts that tend to break or need replacement might be better to print separately, so when there is a need to print a replacement part you don't need to print the whole assembly again. You don't need to use unnecessary material to reprint the whole part, you can just print the one small spare part, saving time and material.

The objects need a flat surface with enough surface area on the part which will be against the 3D printer's bed. Too little surface area might raise the problem of the print not sticking to the print bed and the print coming off the bed in the middle of the print. Tall prints can create a lever effect to the bottom of the print where it is needed to be stuck on the print bed. If the print sticks to the nozzle in any way an insufficient amount of surface area might just let go and come off. But the proper amount of surface area allows for tall, wide and complex parts to be printed reliably.

Tiny and sharp corners, especially corners smaller than  $90^\circ$ , tend to warp. There is too much melted plastic being extruded into the small thin tip of the corner so it warps and may cause a crash during the print. So a good protocol is to avoid small sharp corners and use fillets instead.

When considering the production aspect you need to think of ways to make the production cost less: in print time, material costs and post processing time. If you want to optimize these aspects as best as possible, the best place to start is with the need to eliminate post processing. Post processing such as surface finishing or support removal. All of this takes extra time. Surface finishing, such as lacquer, introduces a new material onto the plastic, which alone can be recycled but after finishing it can no longer be recycled due to the lacquer coating on top. The feel of the product is smoother, but the potential "ecological" benefits are lost.

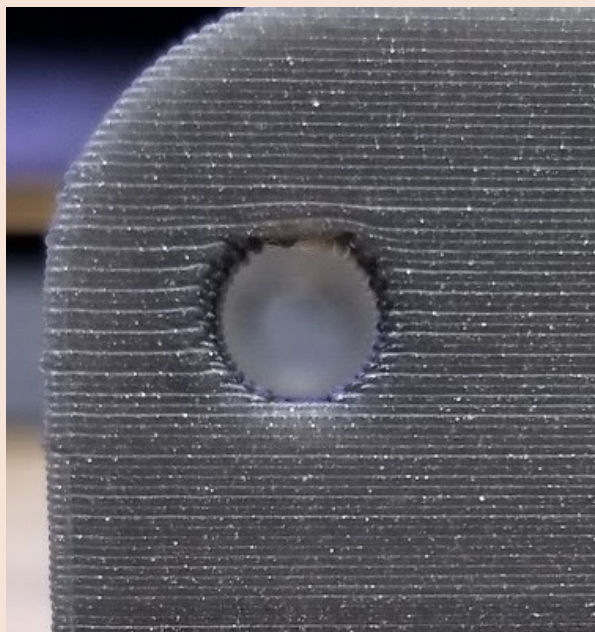

Image 15. Demonstration of a horizontal printed hole.

If the desired end result needs clean and accurate sized holes on your 3D printed parts, the best way for it is to orient the print or to have the holes be parallel, or close to parallel, to the vertical axis. Because of the nature of FDM 3D printing, where the layers of the printed objects are laid horizontally, vertical holes come out clean because they are extruded from the top side looking down, making clean circles. When making vertical holes a regular FDM printer struggles to make them clean. They can be made, but usually the dimensions and tolerances are off, and the top side of the holes tend to sag. Making a hole horizontally layer by layer the quality is dictated by the layer height of the print and the overhang on top of the hole. Some try to fix the top of the hole with support material. A way of going around this problem when creating horizontal holes on prints, without using supports, you can compensate for the overhang sag of the material by creating a teardrop shaped hole, where the top of the teardrops overhang is the maximum of your printer, usually  $55^\circ$ . The tolerance and quality of the bottom of the horizontal hole is still determined by the layer height, but this tends to be the lesser problem when it comes to horizontal holes in prints. Printers are usually able to print small horizontal holes successfully, but when the diameter of the hole grows the overhang problem becomes worse and the problem with the quality is negated. The layer height compared to the hole's size gets much less significant the bigger the hole gets.

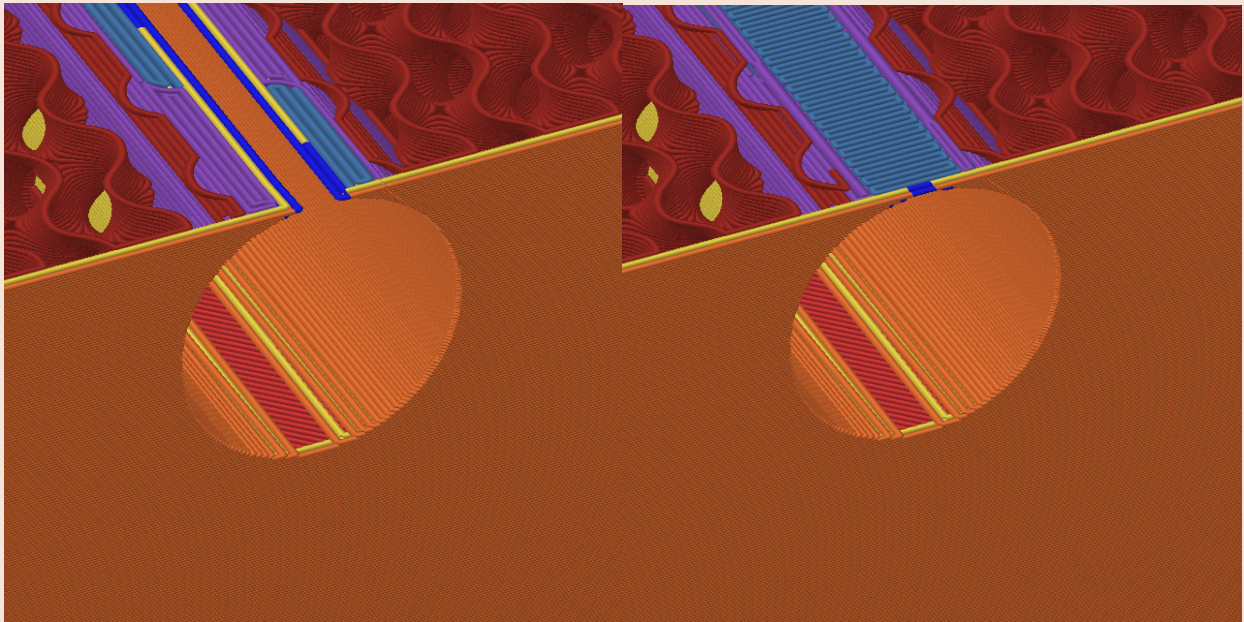

Image 16 and 17. The slicers create bridging above the hole. Depending on the size of the hole this may result in unusable holes.



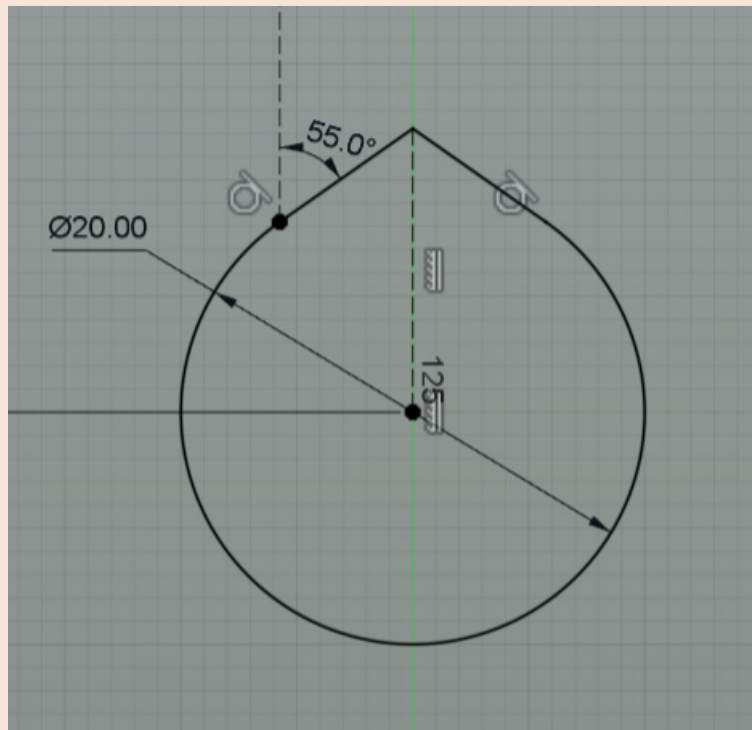

Image 18. You can use your printers maximum angle to make the teardrop.

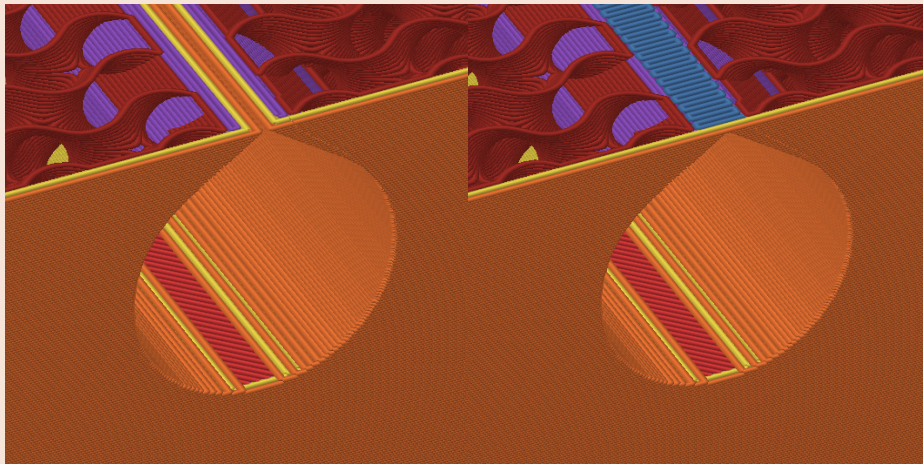

Image 19 and 20. The holes come out with same perimeter operation as the walls.

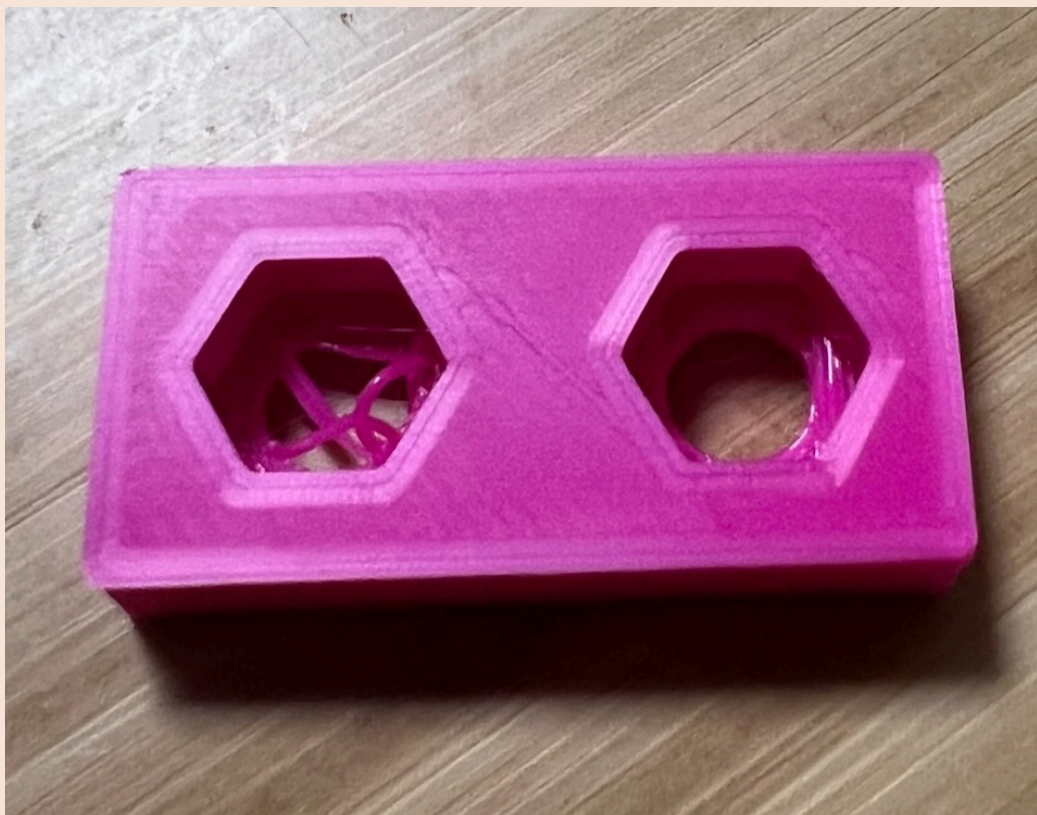

Image 21. Demonstration of countersinks with floating holes.

There is a workaround method for printing countersinks with floating holes. This opens up more possibilities in designing parts for FDM 3D printing so you are not restricted by non-floating holes. To print floating holes without the need for support, you can create targeted bridges around the hole to act as supports. In the 3D model inset straight rectangles around the hole, so on a few layers below where the hole will be printed there will be self inserted bridges for support. This feature is not available in slicers at the moment, but I could imagine it being relatively easy to implement.

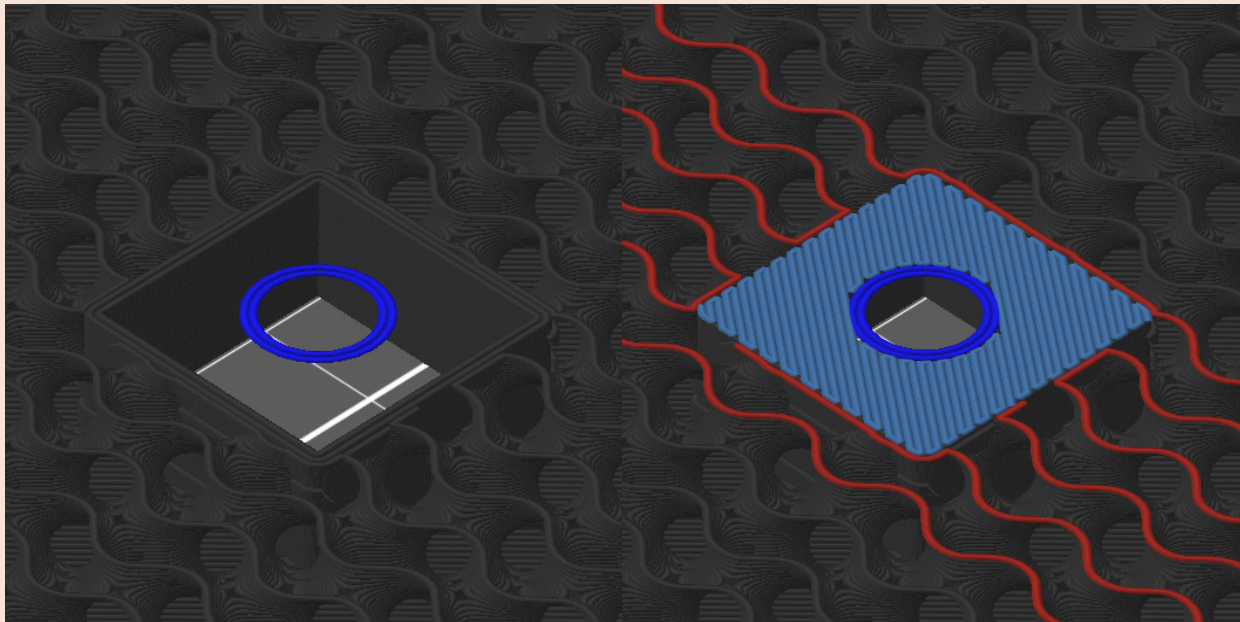

Image 22 and 23. Without support the hole will be printed in the air.

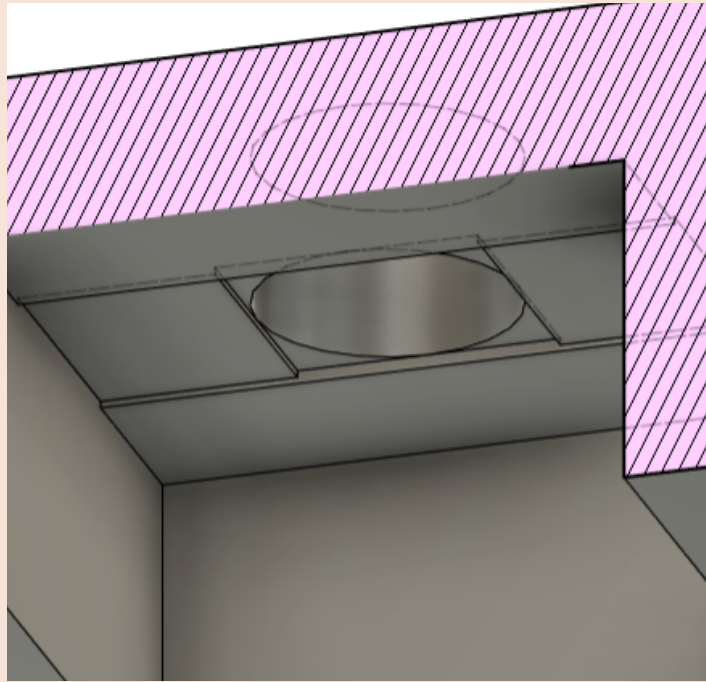

Image 24. Adding steps around the hole.

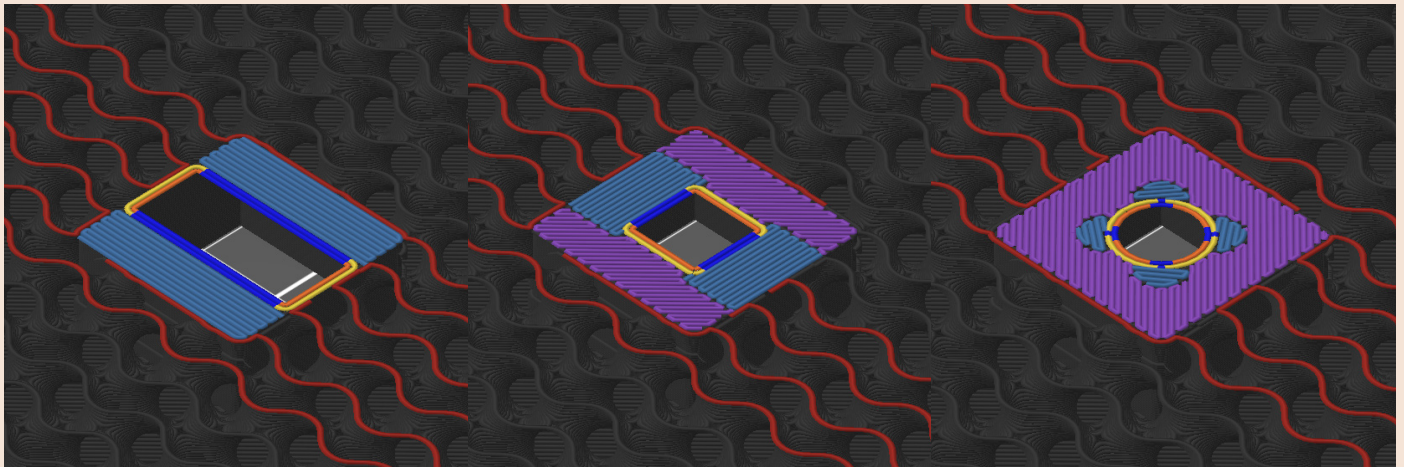

Image 25, 26 and 27. The workaround creates strategically placed bridges to support the perimeter of the hole.



To get a clean print straight off the printer you can also add a small 0.5mm chamfer to the bottom edge of the print, that is against the print bed. This can compensate for a common calibration issue a lot of common 3D printers have, the Elephant's foot. Elephant's foot is the phenomenon of excess material that is protruding over the side of the print on the first layer. This can change the dimensions of the bottom surface. The elephant's foot appears when the first layer extrudes extra material during the printing of the first layer, to guarantee a good bed adhesion for the prints. This can be prevented by calibrating your printer's first layer settings properly to compensate for the correct size elephant's foot. The chamfer that can be added to the 3D models works to compensate for the lack of perfect calibration. The chamfer has no downsides for being on the model even though the printer was calibrated well, it just moves in the first layer a half a millimeter.

### 3.3.4

### Potential

With new innovative ideas concerning 3D printing and slicers popping around the internet, the potentials of FDM 3D printing are pushed further. The open source and open sharing communities quickly test and develop new ideas with the help of tens to thousands of people.

A promising idea is in development in the FDM 3D printing space since 2022, and it could negate the need for supports on FDM prints nearly completely. It has been named “Arc overhang” and was originally developed by Steven McCulloch. Instead of requiring support or bridging on certain  $90^\circ$  (i.e. horizontal) overhangs, arc overhang creates arcs coming out of the supporting geometry on a planar plane. Positioned one next to another, only slightly overlapping, creating a rigid surface seemingly floating in mid air. If you consider how long printing supports take and how much waste is created, arc overhangs become a considerable viable option. (CNC Kitchen. 2022) This is a great addition to existing slicers of today, and once properly implemented would allow more freedom in the design of FDM 3D printed products and reduce waste.

Potentially other kinds of post processing scripts have and are being developed by individuals. Some may have a great impact on the design capabilities for average FDM printers. Like the arc overhang helps reduce more unnecessary supports, other innovations may allow even further pushing the potential of the technology.

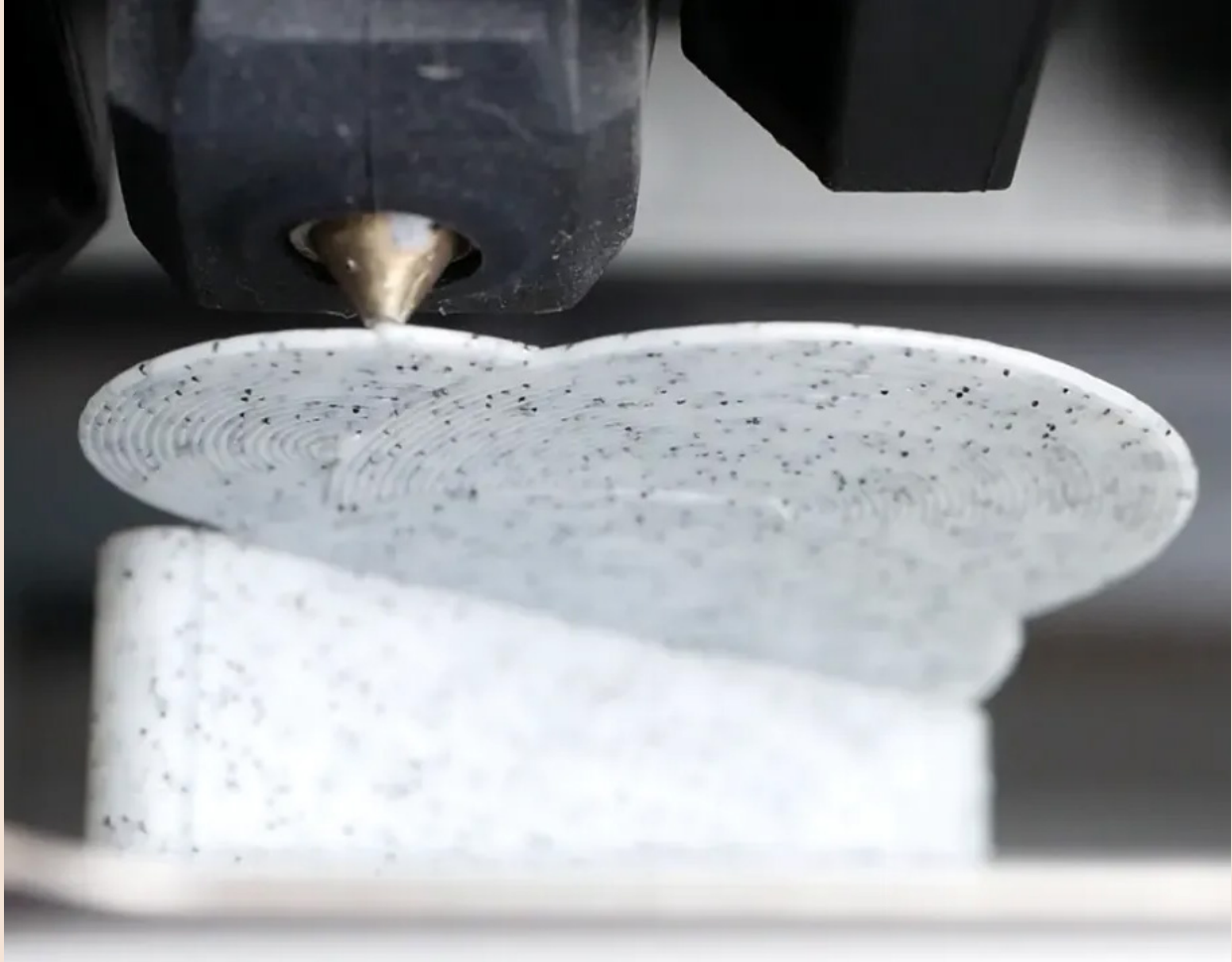

Image 28. Arc overhangs demonstrated on a video by CNC Kitchen.

### **3.4 Design Language Led by the Manufacturing Process**

Couple of the parts designed for the first prototype were greatly influenced by the manufacturing processes. The shape, angles and orientations of geometries were adapted to suit the FDM printing method. Physics of the material, and properties of the manufacturing process had to be considered to come up with an apt solution.

The bottom of the clay container was created as a one piece. Firstly, the bottom part of the container was considered to have the pipe gland be a separate part. But with making the pipe gland and the bottom of the container one single component, the pipe gland could be used as a supporting structure for printing, on the bottom of the part. With other strategically placed supporting geometries, the part could be printed with the place for O-rings oriented upwards, and the threads for the pipe gland be oriented in a way that ensures a clean print. The workaround method for floating holes was also applied on the component. This allows the holes for an M6 threaded rod to go through the component, making the aesthetic clean with the nuts being hidden and positioned away from the bottom of the component.



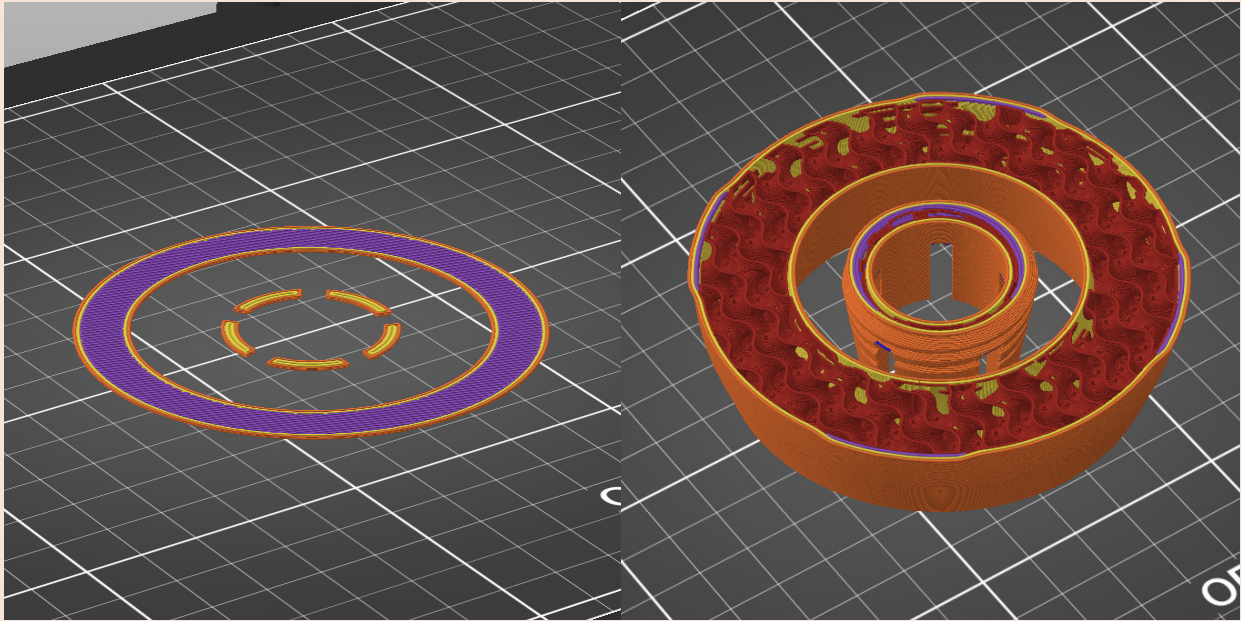

Image 29 and 30. The pipe gland is printed vertically and it acts as the support for the upper part of the part. An outer ring acts as makeshift support.

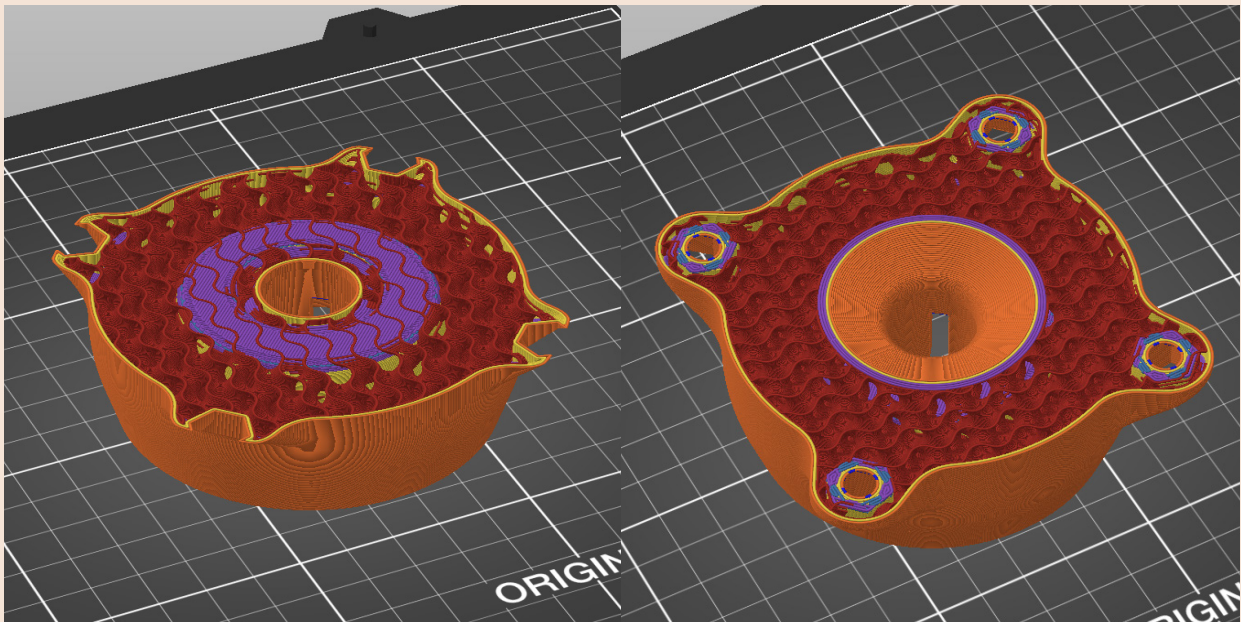

Image 31 and 32. The geometries meet eventually. The floating hole workaround is used in the ears for the threaded rod.



Image 33. The parts can be used straight off of the printer, for there is no post processing needed.

In the same way as the pipe gland was utilized as a support structure, the same approach was used in a component for the extruder. The orientation of the component had to be very specific for the intricate details to come out clean. The threads for the nozzle and pipe gland had to be clean but were oriented in a different direction. There could not be a 90° angle between the threads of the nozzle and the threads of the pipe gland. If there was, the other one had to be printed horizontally, which would leave the threads basically unusable or unprintable. Also there needed to be room for the pipe glands nut to be rotated when needed. The pipe glands end was used as the initial reference point for the design, and the side was protruded to meet the same plane, so it could work as a supporting geometry. The pipe glands teeth surface area was insufficient to ensure bed adhesion alone for the whole complex part. In addition, there was a 50-55° incline added to the bottom of the geometries that the screws that hold the extruder assembly together, to ensure that the geometries were supported and able to be printed clean. The final design of the component was dictated by the orientation and restrictions that FDM technology has.



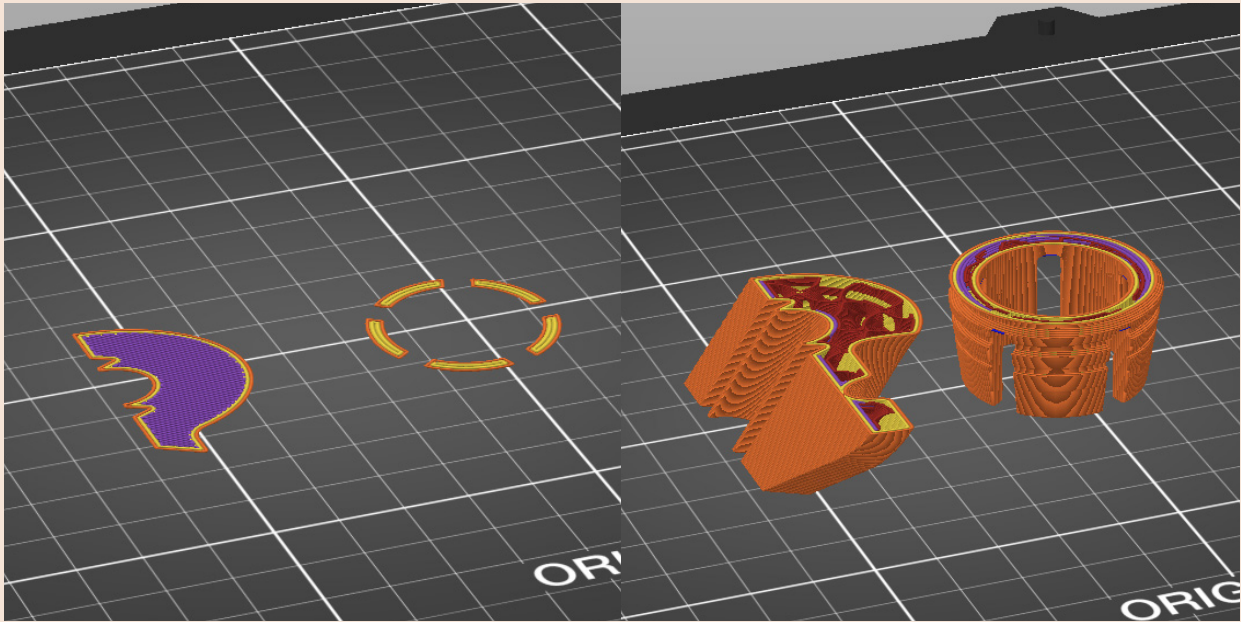

Image 34 and 35. The pipe gland was printed vertically for the threads to print well, The end of the part was angled and used as a supporting geometry.

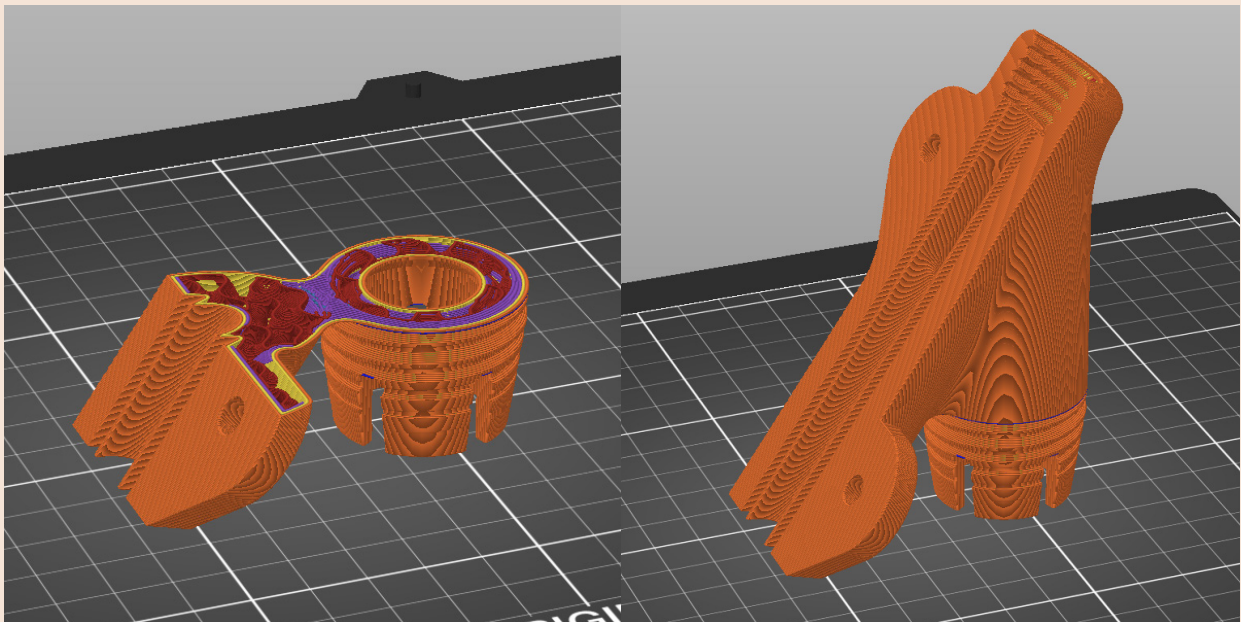

Image 36 and 37. The two geometries meet to create the full part, which is well supported at multiple points.



Image 38. The resulting part is a sleek and functioning component ready to be used straight off of the printer.

### 3.6

### Prototype

The Pressurised tank consists of 3D printed parts pressed on the end of an acrylic tube using M6 threaded rod. The 3D printed parts were made more airtight with printing thick walls and using the “ironing” feature in the slicers. There are O-rings the size of the acrylic tube in between the plastic and acrylic. On the end cap there are threaded holes printed into the part and they are insulated using the same thread tape as normal pneumatic fittings. The nut for the container’s pipe gland is wide and ribbed for added grip and leverage. The Cap of the container can be closed using wing nuts that thread to the end of the M6 threaded rods. The container consists of only four 3D printed parts, normal standardized screw components and pneumatic components sourced from the hardware store, and standard sized o-rings and acrylic pipe.

The extruder assembly consists of five 3D printed parts, a wood drill bit as the auger screw fitted onto the 3D printer’s extruder motor axis with a 3D printer axle fitting, and standard screws and nuts. The 3D printed bracket for the extruder components is attached to the x-carriage using existing holes located on the x-carriage. There is a bearing added over the wood drill, believed to provide stability. The extruder housing was attached to the printed extruder bracket with hex bolts. The clay extruder assembly was mounted onto a Creality Ender 3-V2 3D printer, that was provided by Metropolia University of Applied Sciences and the Industrial Designers 3D printing workshop, to be used for this thesis.

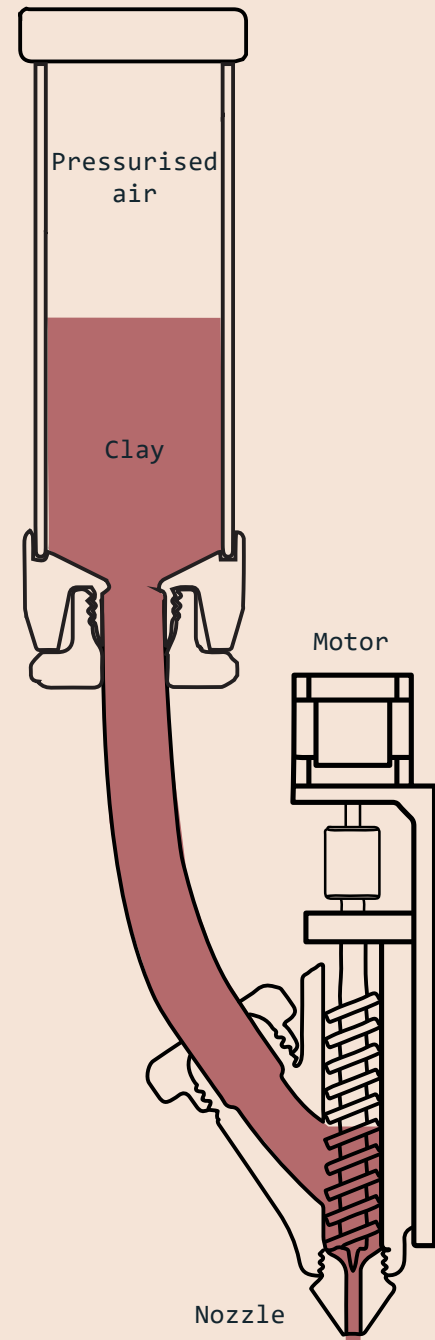



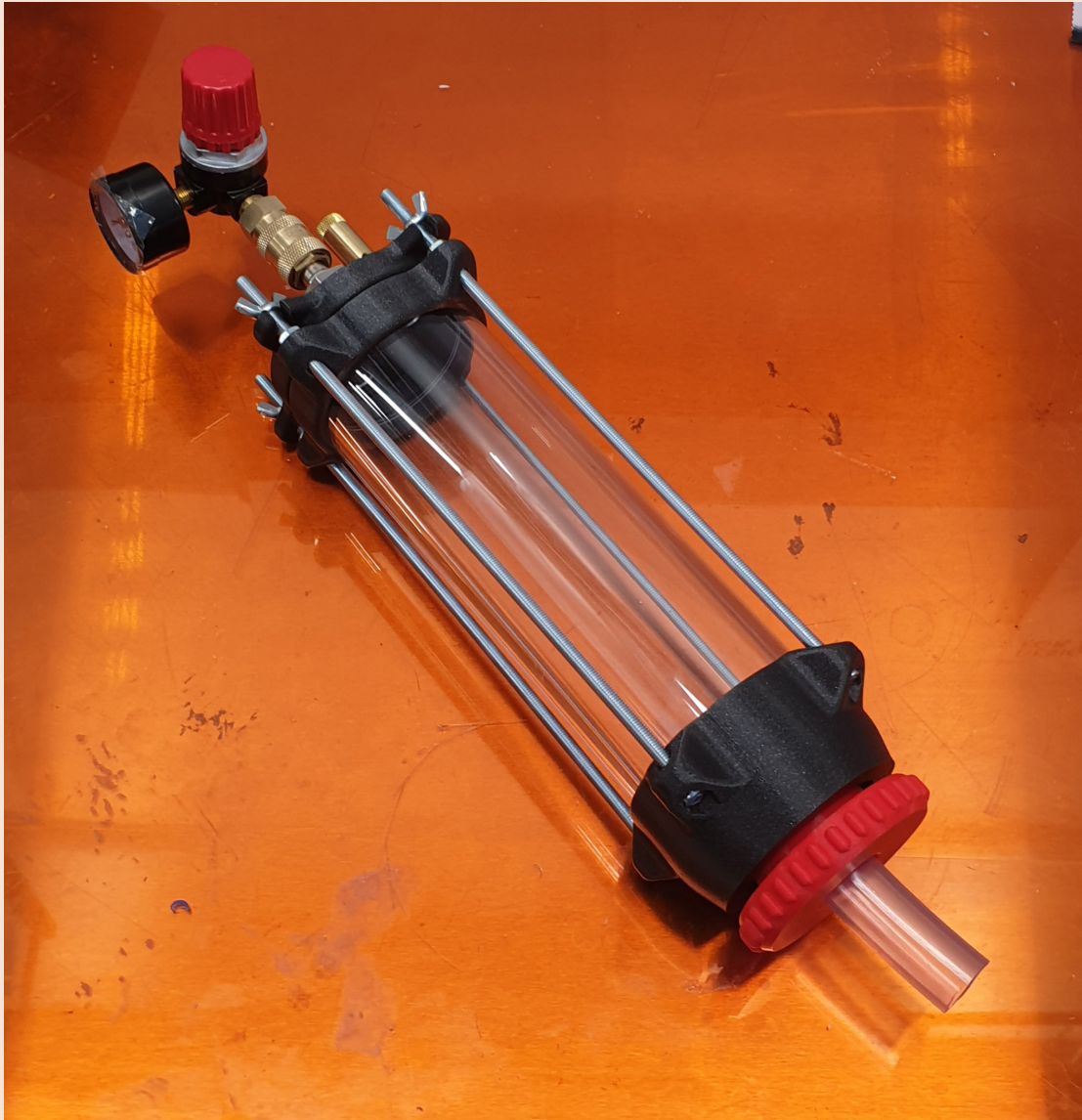

Image 39. The pressurised clay container looks very sleek. The knob for the pipe gland has a big diameter for good leverage.



Image 40. The extruder attached to the 3D printer looks clean and professional. The nozzle is also 3D printed allowing customized nozzle shapes.



After making sure the 3D printer worked as intended, unnecessary components were taken off. All of the components on the x-carriage except the bracket itself were taken off of the printer and disconnected from the motherboard. The entire bed of the printer was taken off of the y-carriage, for the heating element was not needed. A new bed was fitted onto the y-carriage, a simple piece of plywood works well enough. Preferably, it should be a material that can withstand moisture, as the clay may contain some. To be cautious the power supply and motherboard were moved away from the bottom of the printer, in case there was moisture or water dripping from the clay.

To get the prototype printing the firmware of the 3D-printer had to be modified a little. Thanks to the open source communities around the Creality 3D printers it was relatively easy to do. The process of modifying firmware is very well documented on the internet and clear tutorial videos can be found on Youtube. The rotation direction of the extruder motor had to be reversed in the firmware. This was for the wood drill bit to rotate the right way and work as an auger. Also the firmware had restrictions to prevent the rotation of the extruder motor if the nozzle temperature was below a certain temperature. But the clay printing would not require any heating, so the heating elements were removed. A small modification to the firmware was enough to remove the restriction. The nozzle is offset from the original printer's nozzle position, so it had to be compensated for in the firmware. Subsequently the print volume had to be adjusted, the depth and the height to be reduced, the width stayed pretty much the same.

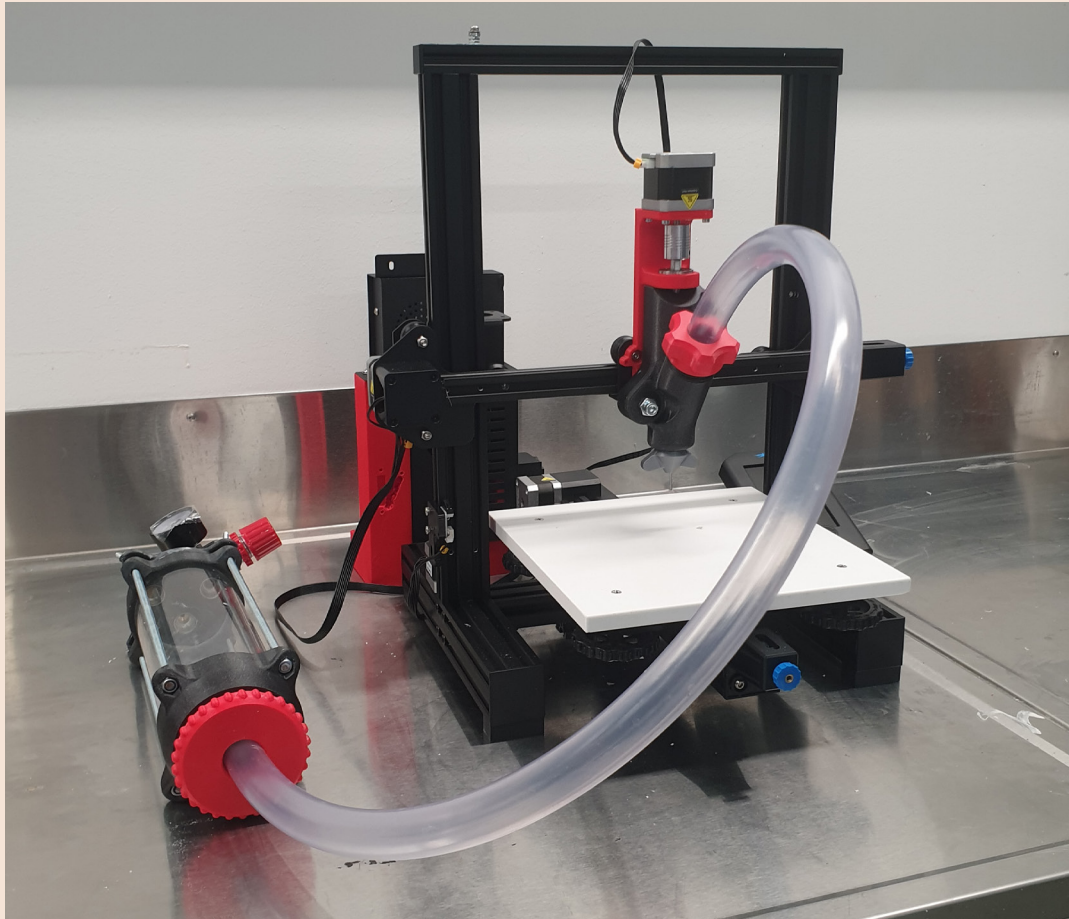

Image 41. The clay printing components fitted on to the printer. Ready for tests.

### 3.7

### Testing

Filling clay into the capsule was a pretty painless task, but a need for some improvements was recognized when doing the operation a couple of times. The removal of the lid of the container was a cumbersome task, having to rotate all of the wing nuts off of the threaded rods. After filling the container with clay the cleaning of the airtight contact surfaces of the O-rings was a must. Furthermore, if the clay is not properly compacted and pushed down into the container, and left with a level surface, the pressurized air used could bore a hole through the middle of the clay, leaving a significant amount of clay in the capsule. Air pockets could accumulate inside of the clay as well if the capsule was not filled properly. The air pockets could later cause problems at the extruder. The pneumatic components worked as intended. The new bed worked great as the printing surface, it was as easy to level as the Ender 3-V2 is leveled normally. The wood drill had to be rotated with speeds that were not safe for the extruder motor to maintain for a prolonged period of time. The extruder motor heated up a lot even during short test prints. The pneumatic system worked great and was able to push the clay along the tube to the extruder at a relatively good pace. The 3D printed integrated pipe gland held the tube in well enough even under pressure.

Finding the right settings for the extruder to print properly takes time and effort. Because of the time constraints for this thesis, the proper calibration settings were not achieved. But some key improvements were recognized, and they will be further improved and iterated on in the second version of the extruder.

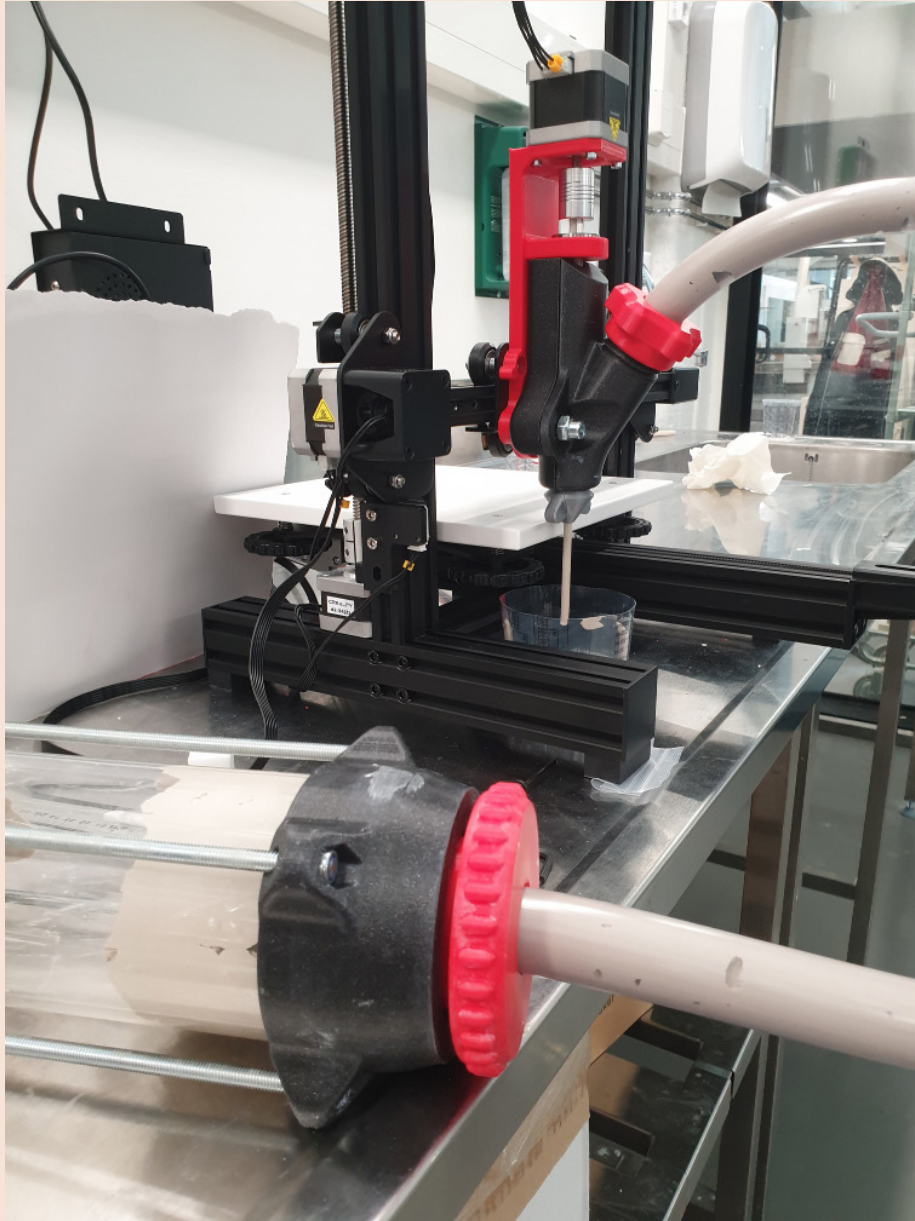

Image 42. The first extrusions of the printer.

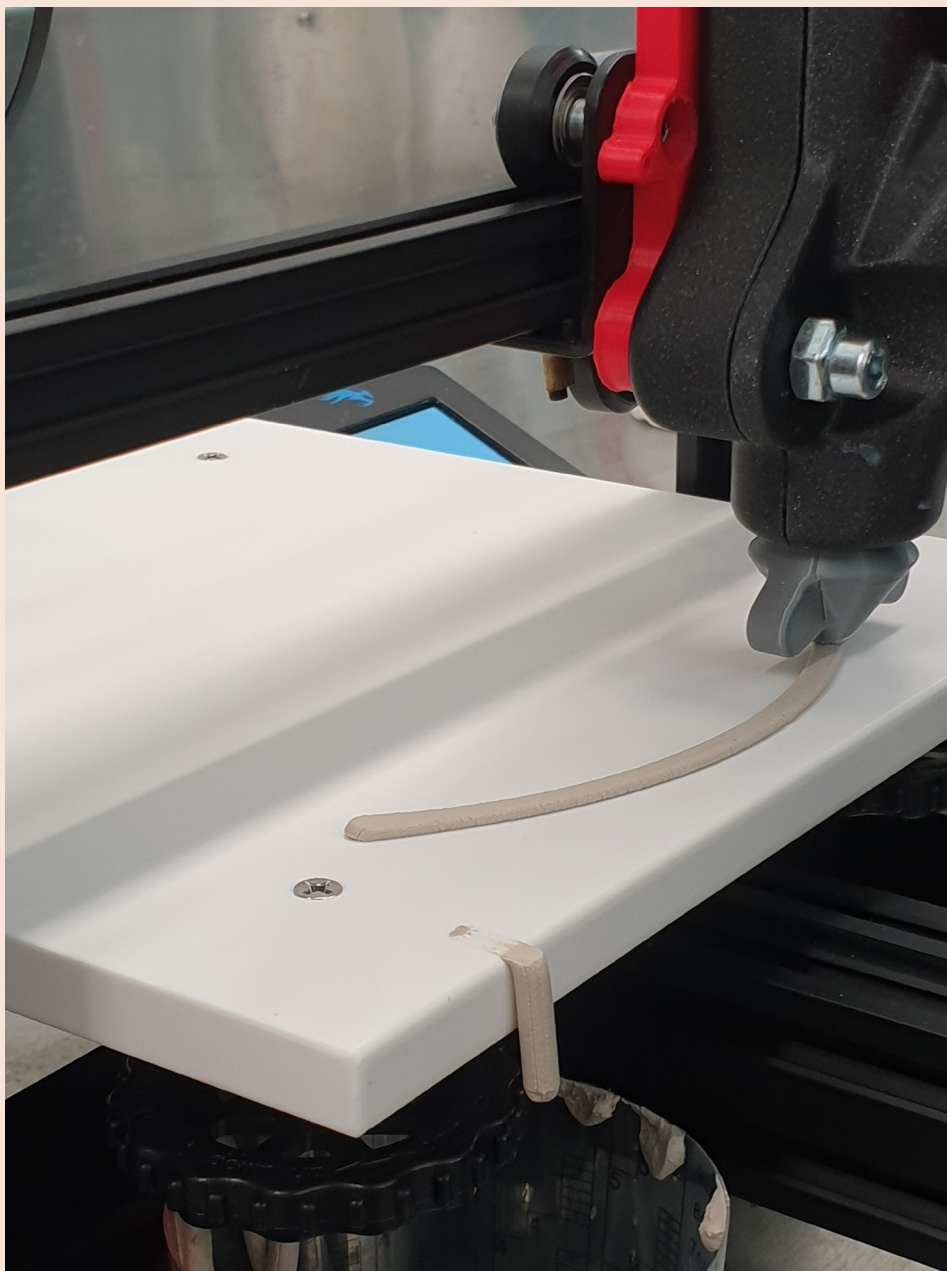

Image 43. The first printed line on the printer with clay.





Image 44. The first test print was really promising. The layers look good. With little optimisation to the settings proper printing will be possible.



Image 45. The first test print after drying.

**04**

**End**

**Result**

The results of this thesis demonstrate that intended adjustment of the design based on the capabilities and restrictions of the manufacturing method, in this case 3D printing, can create clean and consistent parts. The potentials of FDM 3D printing are utilized. Through clever workarounds and design choices many complex shapes can be printed with no support material, thus minimizing waste. Affordable and working prints can easily be manufactured at home with desktop FDM printers, allowing for a more accessible technology. The sleek aesthetic of the extruder makes it look professional, but is still affordable. The affordability and transparency of the manufacturing and assembly encourages experimentation.

The time constraints of this thesis limited further development and testing. Therefore, no further iterations will be made, but only discussed in this thesis. Nevertheless, there are a lot of improvements to make for the second prototype.



## 4.1 Iteration, Development and Improvements

The clay container was cumbersome to handle, and opening it was an annoying task. Designing a functional way to open and close the lid with minimal effort would be desirable to minimize possible errors. While three threaded rods for the whole container might be sufficient, the design of the lid opening will determine if three threaded rods is enough. Additionally, the clay container needs a stand, or needs to be mounted on to the printer, possibly in a similar manner as it was in the printer posted in Thingiverse by Lauhaus. Mounting the container properly could allow the tube to be made shorter, reducing resistance and allowing the clay to move faster. Also, the outlet valve for the pressured air is not great. A more traditional type of a valve would probably work better at indicating the user of its use.

The extruder needs to be modified to enhance safety and ease of use. Reducing the number of parts is beneficial, and removing the 3D printer axel connector from the extruder motor simplifies the sourcing of parts and reduces the necessary tools for use. The connector can be hard to come by due to it being highly specific for 3D printing. The axel connector could be 3D printed and the connecting part could be integrated into a 3D printed auger. Having the auger be 3D printed allows for custom auger profiles, and can be made much more efficient. Correctly orienting the auger negates the need to modify firmware. Lowering the amount of teeth the auger has lowers the speed that the motor needs to spin, making it much cooler when being used. Also the original fan of the 3D printer could be integrated back onto the motor to help cool it even more. Removing the bearing that was attached to the wood drill could be removed as well, lowering the part count. 3D printing knobs in place of the hex bolts allows the extruder to be disassembled without tools. Offsetting the nozzle to be right in the same spot as the original nozzle removes the need to compensate for it in the firmware.

Other little additions that could enhance the use of the printer include a mallet for compacting the clay level into the container and clips to hold paper on the printer bed to help remove prints.

## 05 Conclusions and Thoughts

In the end, the outcome of this thesis is nowhere near as great and grandiose as I was hoping for. The time constraints left the project feeling unfinished for me. It would be really fun and interesting to develop the project further. I wish I would have had the time to print more with clay and design prints with Rhino Grasshopper. Despite all this the thought of enabling users to learn and experiment with my creation drives and inspires me.

Nevertheless, the parts that have been created for the prototype look coherent and professional. The staff at the Metropolia Industrial Design department complimented the looks of the parts and noted that they do not look 3D printed, rather something produced through more traditional manufacturing methods. I found this interesting, because the idea of the thesis is to optimize and utilize the possibilities and capabilities of a FDM 3D printer to make 3D printed parts, in a sense making the parts “as 3D printed as possible”. By making deliberate design decisions the look and feel of the 3D prints are coherent and the surface finish is clean, making the printed parts not look 3D printed at all.

Maybe steering away from the conventional expectations in design makes the parts look like a completely different manufacturing process? Does the “3D printed look” come from the 3D prints mimicking more traditional means of manufacturing? Maybe this kind of utilization of the manufacturing method is not common for FDM 3D printed parts. Even though there was no attempt at hiding the fact that the parts were 3D printed, they still “deceived” viewers, although this was not the intention.

What I hope readers take away from this thesis is that we are at a brink of a new mainstream manufacturing method. We should explore and embrace the possibilities and take advantage of them. Not let old conventions lead the designs. When 3D printing, weigh the intentions of what you're doing and why. 3D printing contributes to the production of plastic and so the production of plastic waste. So the materials matter, the amount of waste you create matters, the intentions and longevity of your creations matter.

Minimizing waste and making well intended and well designed parts is a way of making 3D printing more ecological and sustainable. Allowing access and encouraging experimentation is a path to innovation and in general a greener production method.

# Sources

Abdelkader, M. Petrik, S. Nestler, D. Fijalkowski, M. 2024. Ceramics 3D Printing: A Comprehensive Overview and Applications, with Brief Insights into Industry and Market. *Ceramics* 2024, 7, 68-85.

Carolo, Lucas 2024. What Is FDM 3D Printing? – Simply Explained. All3DP. <<https://all3dp.com/2/fused-deposition-modeling-fdm-3d-printing-simply-explained/>> (Accessed 10.3.2024)

CNC Kitchen. 2022. <<https://www.cnckitchen.com/blog/arc-overhangs-a-new-way-of-printing-without-supports>> (Accessed 29.4.2024)

Fordyce, Robbie. Heemsbergen, Luke. Mignone, Paul. and Nansen, Bjorn. 2015. 3D printing and university makerspaces: Surveying countercultural communities in institutional settings. *Digital Culture & Education*, 7(2), 192-205.

Głażewska, Magda 2020. Open-Source: The Future of Product Design. Medium. <<https://medium.com/@magdagaewska/open-source-the-future-of-product-design-e0579aa81e41>> (Accessed 10.3.2023)

Kadushin, Ronen 2010. Open Design manifesto. <<https://www.ronen-kadushin.com/open-design-manifesto>> (Accessed 10.3.2024)

Keep, Jonathan 2020. A Guide to Clay 3D Printing

Kuznetsov, Stacey. Paulos, Eric. 2010. Rise of the Expert Amateur: DIY Projects, Communities, and Cultures. *NordiCHI 2010: Extending Boundaries - Proceedings of the 6th Nordic Conference on Human-Computer Interaction*. 295-304.

Lawless, Ross 2023. Ceramic 3D Printing: Clay 3D Printing Simply Explained. All3DP. <<https://all3dp.com/2/ceramic-3d-printing-clay-simply-explained/>> (Accessed 11.3.2024)

Norton, Michael I. Mochon, Daniel. Ariely, Dan. 2011. The “IKEA Effect”: When Labor Leads to Love. *Journal of Consumer Psychology*, Volume 22, Issue 3, 453-460.

Norton, Michael I. Mochon, Daniel. Ariely, Dan 2012. Bolstering and Restoring Feelings of Competence via the IKEA Effect. International Journal of Research in Marketing, Volume 29, Issue 4, 363-369.

Opensource.com <<https://opensource.com/resources/what-open-source>> (luettu 10.4.2024)

Pereira, Tanisha. Kennedy, John. Potgieter, Johan. 2019. A comparison of traditional manufacturing vs additive manufacturing, the best method for the job. Procedia Manufacturing. 30. 11-18.

Prusa Research. Printable parts for Original Prusa.  
<[https://help.prusa3d.com/article/printable-parts-for-original-prusa\\_1824](https://help.prusa3d.com/article/printable-parts-for-original-prusa_1824)>  
(Accessed 10.3.2024)

Protolabs 2023. 3D Printing Trend Report 2023.

RepRap. 2023 <<https://reprap.org/wiki/RepRap>> (Accessed 10.3.2024)

Ultimaker <<https://ultimaker.com/learn/the-complete-history-of-3d-printing/>>  
(Accessed 10.3.2024)

Wikipedia. Cura (software) <[https://en.wikipedia.org/wiki/Cura\\_\(software\)](https://en.wikipedia.org/wiki/Cura_(software))>  
(Accessed 10.4.2024)

Wikipedia. Slic3r <<https://en.wikipedia.org/wiki/Slic3r>> (Accessed 10.4.2024)

# Image Sources

Cover picture, image 1 and 2. Lilja Nikkilä

Image 3. Lauhaus, Bricoleur Clay Extruder, Open Source. <<https://www.thingiverse.com/thing:1413969>>

Image 4. Ultimaker Cura. Screenshot taken by Lilja Nikkilä.

Image 5. davidsfeir. Paste extruder for ender 3 (de-airing). <<https://www.thingiverse.com/thing:6167748>>

Image 6. Lauhaus, Bricoleur Clay Extruder, Open Source. <<https://www.thingiverse.com/thing:1413969>>

Image 7. Piotr Wasniowski, Cheap de-airing clay extruder. <<https://www.thingiverse.com/thing:4805607>>

Image 8. Bryan cera, CERA-1 Clay 3D Printer Extruder. <<https://www.thingiverse.com/thing:4251952>>

Image 9-13. Lilja Nikkilä

Image 14. Ahren Alexander, Overhangs overview. <<https://medium.com/@ahrengantri/overhangs-overview-e1c5b6c9563b>>

Image 15. Michelle Drennan, Printing the Most Circular Circle along the Z-axis. <<https://re3d.zendesk.com/hc/en-us/community/posts/360057694271-Printing-the-Most-Circular-Circle-along-the-Z-axis>>

Image 16-20. Lilja Nikkilä

Image 21. Aaron Patterson, 3D Printing a Countersink with a Floating Hole. <<https://cohost.org/tenderlove/post/755788-3d-printing-a-counte>>

Image 22-27. Lilja Nikkilä

Image 28. CNC Kitchen, Revolutionary Arc Overhangs are now in PrusaSlicer\*. <[https://www.youtube.com/watch?v=TGa\\_KvKLD8R](https://www.youtube.com/watch?v=TGa_KvKLD8R)>

Image 29-45. Lilja Nikkilä