



VAASAN AMMATTIKORKEAKOULU  
UNIVERSITY OF APPLIED SCIENCES

Sharmin Yasmin

# FINGERPRINT DOOR LOCK SYSTEM USING ARDUINO

School of Technology  
2023

## **ABSTRACT**

Author	Sharmin Yasmin
Title	Fingerprint Door Lock System Using Arduino
Year	2023
Language	English
Pages	38
Name of Supervisor	Jani Ahvonen

---

This thesis presents the design and implementation of a fingerprint door lock system using Arduino Uno microcontroller.

The system uses a fingerprint sensor module to authenticate users and control an electronic door lock for secure access. The hardware components used in this system include Arduino Uno, fingerprint sensor module, a relay module, solenoid door lock and an adapter. The software components include a program for interfacing the fingerprint sensor with Arduino. The system was tested for functionality, security, and usability. The result shows that the system is capable of accurately identifying authorized users and granting them access while preventing unauthorized access.

---

Key words            Microcontroller, Arduino, authenticate, relay

## CONTENTS

ABSTRACT.....	2
LIST OF FIGURES .....	4
LIST OF TABLES .....	5
INTRODUCTION .....	6
1. LITERATURE OVERVIEW.....	7
2. METHODOLOGY.....	8
3. DESCRIPTION OF THE HARDWARE COMPONENTS.....	9
3.1 Hardware Block Diagram .....	9
3.2 Arduino Uno.....	9
3.3 Fingerprint Sensor Module .....	12
3.4 Solenoid Door Lock .....	15
3.5 Relay Module .....	17
3.6 Adapter .....	18
4. SOFTWARE COMPONENTS .....	21
4.1 Explanation of The Code .....	21
5. WORKING PROCEDURES.....	25
5.1 Testing The System .....	29
6. EVALUATION OF THE FINGERPRINT DOOR LOCK SYSTEM .....	30
6.1 Advantages.....	30
6.2 Disadvantages .....	31
6.3 Cost Calculations.....	32
7. SAFETY MEASURES .....	34
8. CONCLUSION .....	35
9. REFERENCES.....	38

## LIST OF FIGURES

<b>Figure 1.</b> Flow Diagram.	8
<b>Figure 2.</b> Hardware block diagram.	9
<b>Figure 3.</b> Arduino Front (Arduino, 2022).	10
<b>Figure 4.</b> Arduino Back (Arduino, 2022).	11
<b>Figure 5.</b> Arduino pinout diagram (Arduino, 2022).	11
<b>Figure 6.</b> Front view of the fingerprint sensor (Farnell, 2023).	14
<b>Figure 7.</b> Back view of the fingerprint sensor (Farnell, 2023).	14
<b>Figure 8.</b> Connection diagram of the fingerprint sensor (Farnell, 2023).	15
<b>Figure 9.</b> Solenoid door lock (Farnell , 2023).	16
<b>Figure 10.</b> Relay module (Farnell, 2022).	18
<b>Figure 11.</b> Adapter (Farnell, Power & Line Protection> Power Supplies, 2022).	19
<b>Figure 12.</b> Snippet of code 1.	21
<b>Figure 13.</b> Snippet of code 2.	22
<b>Figure 14.</b> Snippet of code 3.	23
<b>Figure 15.</b> First step connection of my system.	26
<b>Figure 16.</b> Second part connection of my system.	27
<b>Figure 17.</b> Final connection of the system.	28
<b>Figure 18.</b> Power feeding to the system from the testing station.	29

## LIST OF TABLES

Table 1. Technical information of Arduino board	P-12
Table 2. Technical information of fingerprint sensor	P-13
Table 3. Technical information of fingerprint sensor	P-16
Table 4. Technical information of relay module.	P-18
Table 5. Technical information of Adapter.	P-19,20
Table 6. Cost calculation of the system.	P-32,33

## **INTRODUCTION**

Lock systems have been around for centuries, and traditional lock systems are still being used today. However, these systems are no longer considered secure and convenient as they are prone to various vulnerabilities. The rise of technology has led to the development of advanced door lock systems that are more secure and convenient than traditional lock systems. Biometric door lock systems are one such technology that uses a person's unique physical traits for authentication purposes. Fingerprint door lock systems are becoming increasingly popular due to their security and convenience. This thesis presents the design and implementation of a fingerprint door lock system using Arduino Uno microcontroller.

## **1. LITERATURE OVERVIEW**

The use of biometric authentication systems for access control has become increasingly popular in recent years due to their high security and convenience. One of the most widely used biometric technologies is fingerprint recognition, which is based on the unique pattern of ridges and valleys on an individual's fingertip.

Several studies have been conducted on fingerprint recognition systems, and various techniques have been developed to improve their accuracy and reliability. One study by (Jain, Chen, & Demirkus, 30 November 2006) analyzed the performance of different fingerprint recognition algorithms and found that the minutiae-based approach, which extracts and matches minutiae points on the fingerprint, is the most reliable and accurate technique.

The use of Arduino boards in various projects, including biometric authentication systems, has also gained popularity due to their ease of use and affordability. Another study which achieved high accuracy and reliability was by (Martin, 2018).

In addition, several studies have investigated the security of fingerprint recognition systems and potential vulnerabilities, such as spoofing attacks. A study by (Chugh, Cao, & Jain, 2017) proposed a new approach to detect and prevent spoofing attacks in fingerprint recognition systems using machine learning techniques.

Overall, the literature suggests that fingerprint recognition systems are a reliable and secure method of access control, and the use of Arduino boards and machine learning techniques can improve their accuracy and security.

## 2. METHODOLOGY

The methodology section describes the design and implementation of the fingerprint door lock system using Arduino Uno microcontroller. The system consists of hardware and software components. The hardware components include Arduino Uno, fingerprint sensors module, relay module, solenoid door lock, some jumper wires, and an adapter. The software components include a program for interfacing the fingerprint sensor with Arduino. The system was designed and implemented using the Arduino IDE software, and the programming language used was C++.

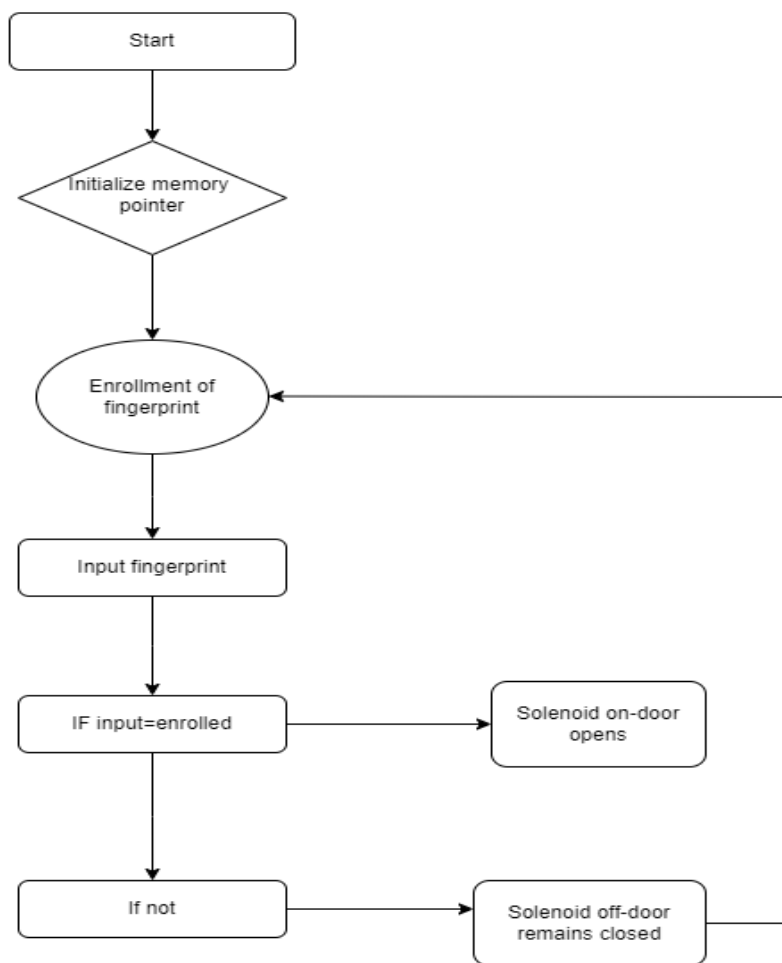
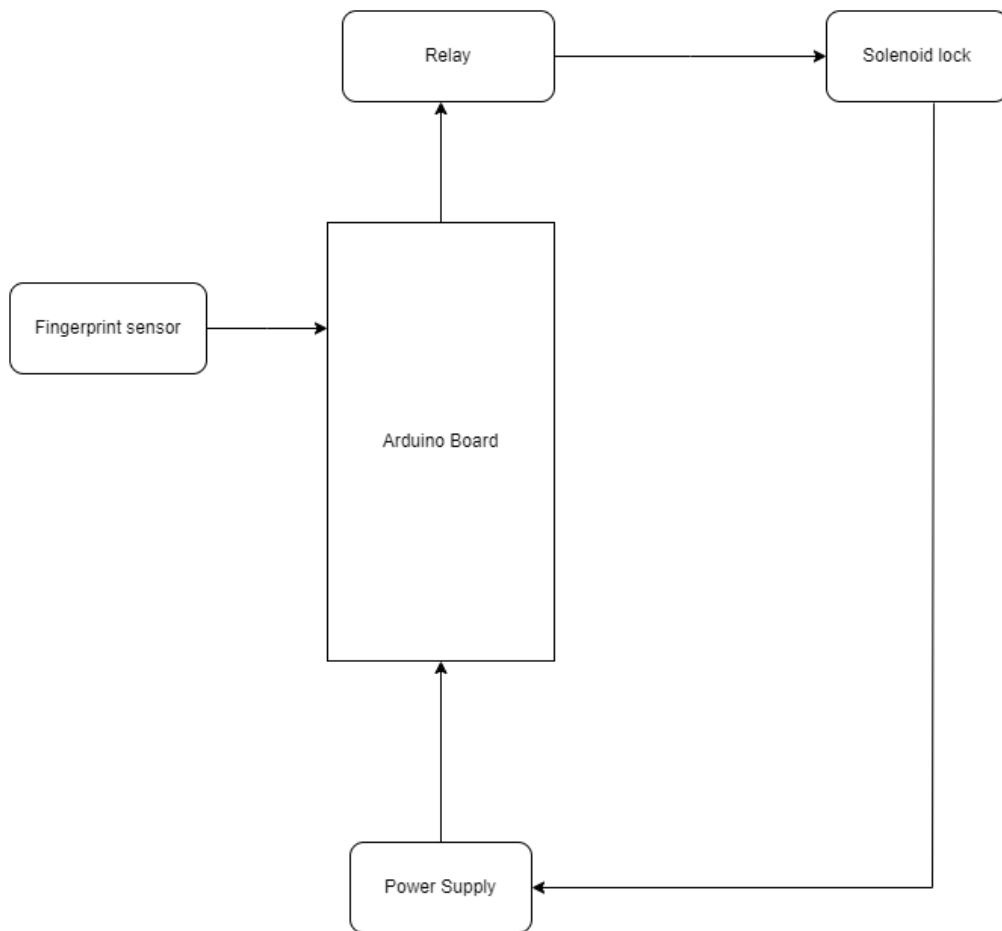

Figure 1. Flow Diagram.



### 3. DESCRIPTION OF THE HARDWARE COMPONENTS

#### 3.1 Hardware Block Diagram

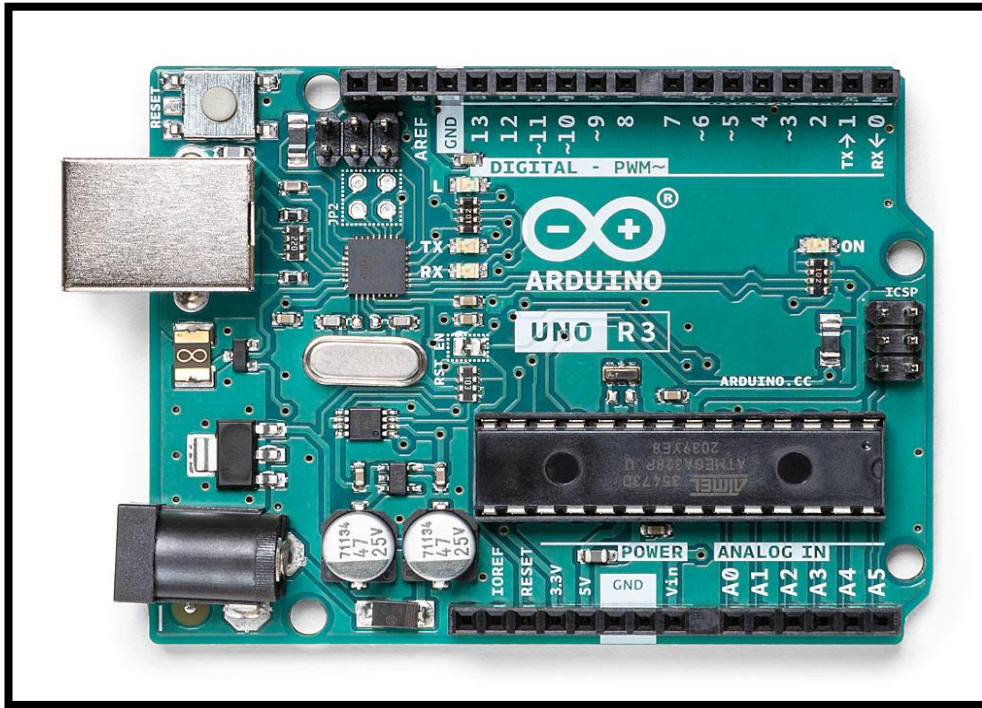

**Figure 2.** Hardware block diagram.

#### 3.2 Arduino Uno

The Arduino UNO is the best board to get started with electronics and coding. In the beginning with the platform, this UNO is the most robust board that can be started playing with. The UNO is the most used and documented board of the whole Arduino family.

This microcontroller is the central processing unit of the system. It controls all the other components and processes fingerprint data.



**Figure 3.** Arduino Front (Arduino, 2022).

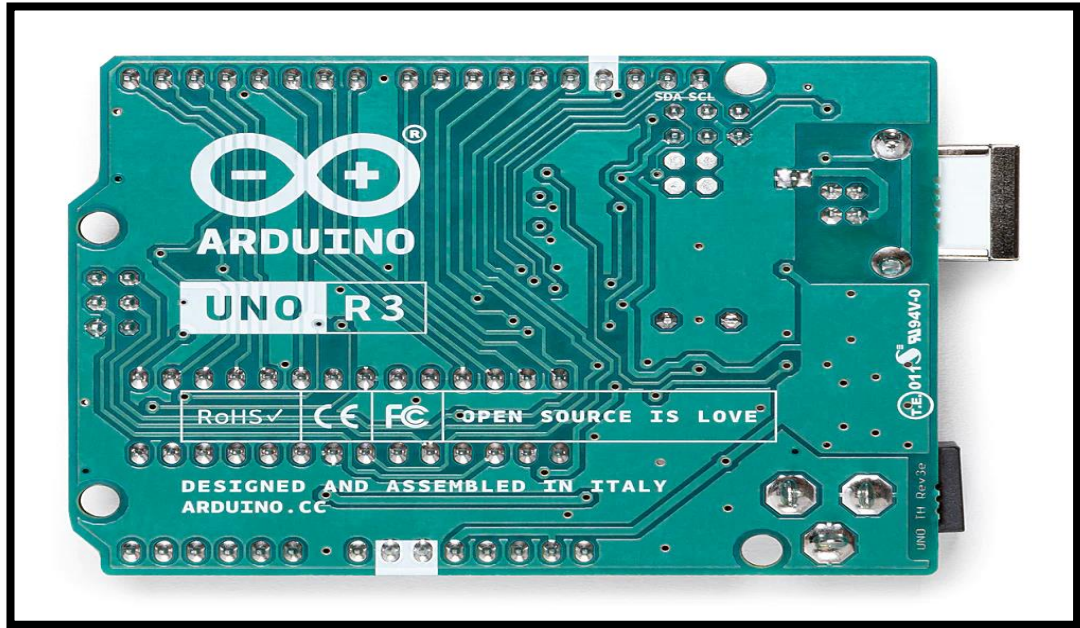

Figure 4. Arduino Back (Arduino, 2022).

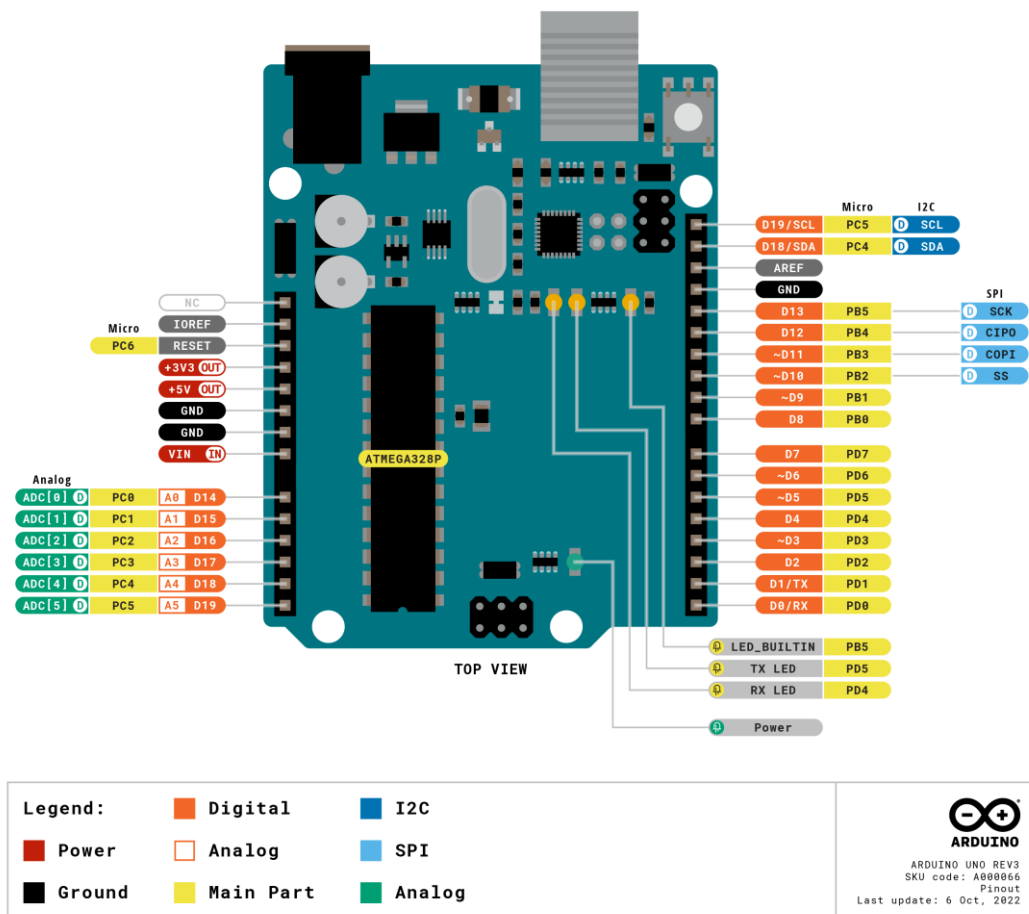

Figure 5. Arduino pinout diagram (Arduino, 2022).

The technical specifications of Arduino are shown in Table 1 (Arduino, 2022).

Specification	Values
Microcontroller	ATmega328P
Operating Voltage	5V
Input Voltage (recommended)	7-12V
Input Voltage (limit)	6-20V
Digital I/O Pins	14 (of which 6 provide PWM output)
PWM Digital I/O Pins	6
Analog Input Pins	6
DC Current per I/O Pin	20 mA
DC Current for 3.3V Pin	50 mA
Flash Memory	32 KB (ATmega328P) of which 0.5 KB used by bootloader
SRAM	2 KB (ATmega328P)
EEPROM	1 KB (ATmega328P)
Clock Speed	16 MHz
LED_BUILTIN	13
Length	68.6 mm
Width	53.4 mm

### 3.3 Fingerprint Sensor Module

SEN0188 fingerprint sensor was used in this thesis project. It can be easily integrated into various biometric projects. It is compatible with Arduino development boards and can be used to implement secure access control systems, attendance management systems, and other biometric applications. The sensor module is equipped with a high-resolution optical scanner that can capture fingerprints with high accuracy and speed.

The SEN0188 fingerprint sensor module has a compact design and is easy to install. It communicates with Arduino boards via a serial interface and can store up to 1000 fingerprint templates in its internal memory. The module also features a

built-in LED indicator and buzzer that provide real-time feedback during fingerprint scanning.

Overall, SEN0188 is a versatile and reliable fingerprint sensor module that can be used in a variety of biometric projects. Its ease of use and compatibility with Arduino boards make it an ideal choice for hobbyists and professionals alike.

The technical specifications of the sensor are shown in Table 2 (Farnell, 2023).

Parameter	Value
Power supply	DC 3.8V-7.0V
Operating current	65mA (Typical)
Interface	UART (TTL logical level)
Baud rate	(9600*N)bps, N=1~12(default N=6, 57600bps)
Image acquisition time	<1S
Storage capacity	1000
FAR	<0.001%
FRR	<1.0%
Average searching time	<1s (1:500, average)
Matching mode	Comparison mode (1:1) and search mode (1:N)
Character file	256 bytes
Template file	512 bytes
Security level	5(1,2,3,4,5(highest))
Working environment	Temp: -20°C - +60°C; RH: 40%-85%
Storage environment	Temp: -40°C - +85°C; RH: <85%
Touch area dimension	14.5*19.4 mm
Outline dimension	542020.5 mm



**Figure 6.** Front view of the fingerprint sensor (Farnell, 2023).



**Figure 7.** Back view of the fingerprint sensor (Farnell, 2023).

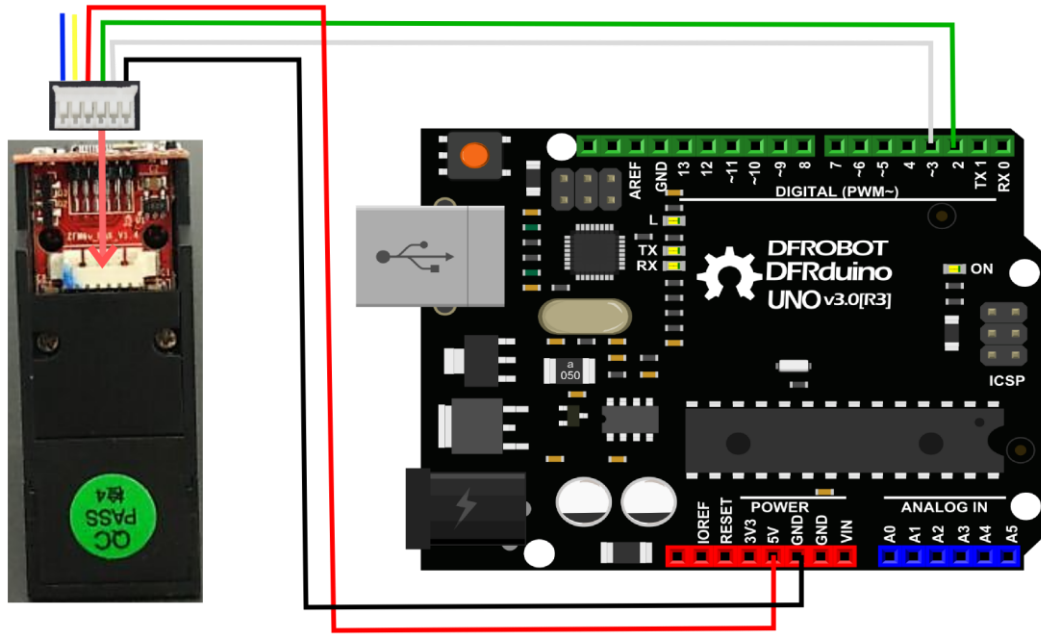

**Figure 8.** Connection diagram of the fingerprint sensor (Farnell, 2023).

### 3.4 Solenoid Door Lock

The MP001161 Solenoid Lock is a compact and powerful locking mechanism designed for various applications that require secure access control. It operates at 12V DC and consumes 18W of power, making it suitable for a range of electronic locking systems.

This solenoid lock is known for its reliability, durability, and efficient performance. It features a solenoid coil that, when energized, generates a magnetic field, allowing the lock to engage or disengage. The lock mechanism is designed to securely hold or release a latch or bolt, providing a reliable locking and unlocking mechanism.



**Figure 9.** Solenoid door lock (Farnell, Automation & Process Control> , 2023).

Technical information about the solenoid door lock is shown in table 3 (Farnell, Automation & Process Control> , 2023).

Parameter	Value
Insulation Resistance	500V DC, $\geq 50M\Omega$
Dielectric Strength	700V AC 50/60Hz
Insulation Level	Class B (130°C)
Wattage	18W (12V DC, $R=8\Omega\pm 10\%$ )
Stroke-Force	6mm pull: $\geq 250gf$ (12V DC)
Work Cycle	Passing 0.05 seconds, breaking 0.15 seconds, max. power-on time, 10 seconds (ED 25%)
Temperature Rise	$\leq 80^\circ C$ (12V DC, 0.05 second break 0.15 seconds, no load)
Response Time	$\geq 50mS$ (12V DC, $S=10.5mm$ , no load)
Leading Strength	1Kgf-30 seconds
Life	$\geq 500,000$ times (12V DC, pass 0.05 seconds, break 0.15 seconds once, load (institution))



### 3.5 Relay Module

The module is used to control the electronic door lock. It is activated by the Arduino Uno if the fingerprint data matches one in the database.

The 103020010 latching relay module is an electronic module that uses a latching relay to control the switching of an electrical circuit. The module is compact and easy to use, making it a popular choice for various applications that require remote control of electrical circuits.

The module typically consists of a latching relay, a control circuit, and an interface for connecting to an external control device, such as a microcontroller or a switch. It operates on a low input voltage and provides a high output voltage, making it ideal for use in battery-operated devices.

This module is based on 2-Coil Latching Relay. In contrast to the ordinary relay, this latching relay does not need continuous power to keep the state, only a rising/falling pulse is needed to change the work state. Even the power can be removed when the work state does not need to change, making this module especially suitable for low power projects.



**Figure 10.** Relay module (Farnell, Embedded Development Kit Accessories, 2022).

The technical specifications of the relay module are shown in Table 4 (Farnell, Embedded Development Kit Accessories, 2022)

Parameter	Value	Unit
Working Voltage	4.7 - 5.3	VDC
Set/Reset Voltage (Max)	4.0	VDC
Coil Resistance	151 - 183	$\Omega$
Switching Voltage (Max)	35	VAC/DC
Switching Current (Max)	3	A
Set Time (Latching)	4.5	ms
Reset Time (Latching)	3.5	ms

### 3.6 Adapter

The MP007780 adapter is an AC-DC adapter that provides a 12V output with a maximum current of 2A. It is designed to convert AC power from a wall outlet into DC power that can be used to power electronic devices. The adapter has a compact and lightweight design, making it easy to carry and store. It has an input voltage of 100-240V AC, making it compatible with different power systems worldwide. The output connector is a standard 5.5mm x 2.1mm barrel plug, which is widely used in many electronic devices. The adapter is ideal for powering low-power electronic devices such as Arduino boards, LED strips, CCTV cameras, and other similar devices. It has over-current and short-circuit protection, which helps to ensure the safety of the connected devices.



**Figure 11.** Adapter (Farnell, Power & Line Protection> Power Supplies, 2022).

The technical specifications of the adapter are shown in Table 5 (Farnell, Power & Line Protection> Power Supplies, 2022).

Model	MP007778	MP007779	MP007780	MP007781
Output				
DC Voltage	5V DC	9V DC	12V DC	24V DC
Rated Current	3Amp	2.5Amp	2Amp	1Amp
Current Range	0Amp to 3Amp	0Amp to 2.5Amp	0Amp to 2Amp	0Amp to 1Amp
Rated Power	24 Watt	24 Watt	24 Watt	24 Watt
Ripple & Noise	240mVp-p max	240mVp-p max	240mVp-p max	240mVp-p max
Output Regulation	±5%	±5%	±5%	±5%
Output Connector	2.1mm × 5.5mm × 12mm C+ve	2.1mm × 5.5mm × 12mm C+ve	2.1mm × 5.5mm × 12mm C+ve	2.1mm × 5.5mm × 12mm C+ve
Input				
Voltage Range	90V AC to 264V AC	90V AC to 264V AC	90V AC to 264V AC	90V AC to 264V AC
Frequency Range	47Hz to 63Hz	47Hz to 63Hz	47Hz to 63Hz	47Hz to 63Hz
Input Current	1.2Amp Max	1.2Amp Max	1.2Amp Max	1.2Amp Max

Inrush Current	40Amp Max	40Amp Max	40Amp Max	40Amp Max
Standby Power	0.1W Max	0.1W Max	0.1W Max	0.1W Max
Leakage Current	0.25Amp Max	0.25Amp Max	0.25Amp Max	0.25Amp Max
Input Connector	Euro	Euro	Euro	Euro
Environment				
Storage Temperature	-20°C to +80°C	-20°C to +80°C	-20°C to +80°C	-20°C to +80°C
Operating Temperature	0°C to 40°C	0°C to 40°C	0°C to 40°C	0°C to 40°C
Cooling	Convection	Convection	Convection	Convection
Temperature Coefficient	0.05 %/°C	0.05 %/°C	0.05 %/°C	0.05 %/°C
Humidity	5%RH to 95%RH (non-condensing)	5%RH to 95%RH (non-condensing)	5%RH to 95%RH (non-condensing)	5%RH to 95%RH (non-condensing)

## 4. SOFTWARE COMPONENTS

The fingerprint sensor interface program is used to interface the fingerprint sensor with Arduino Uno. It captures the fingerprint data and sends it to the Arduino Uno for processing.

The user interface program provides a graphical user interface (GUI) for managing the system. It allows users to add, delete, and modify fingerprints in the database, view system status, and control the electronic door lock.

### 4.1 Explanation of The Code

```
#include <Adafruit_Fingerprint.h> // Include the Adafruit Fingerprint library
SoftwareSerial mySerial(2, 3); // Create a SoftwareSerial object for communication with the fingerprint
sensor

Adafruit_Fingerprint finger = Adafruit_Fingerprint(&mySerial); // Create an instance of the
Adafruit_Fingerprint class

#define RELAY_PIN 4 // Define the pin number for the relay module
#define ACCESS_DELAY 5000 // Define the delay time for granting access

void setup()
{
  // Set up the serial communication with the fingerprint sensor
  finger.begin(57600);
  delay(5);
  // Verify the password of the fingerprint sensor
  if (finger.verifyPassword())
  {
  }
}
```

Figure 12. Snippet of code 1.

```

else
{
    while (1) { delay(1); } // If the password verification fails, enter an infinite loop
}

// Set the RELAY_PIN as an output and turn off the relay initially
pinMode(RELAY_PIN, OUTPUT);
digitalWrite(RELAY_PIN, HIGH);
}

void loop()
{
    // Check if a fingerprint is detected and matches with the stored fingerprints
    if (getFingerPrint() != -1)
    {
        // If a match is found, activate the relay to grant access
        digitalWrite(RELAY_PIN, LOW);
        delay(ACCESS_DELAY);
        digitalWrite(RELAY_PIN, HIGH);
    }
    delay(50); // Add some delay before the next fingerprint scan
}

// Function to capture and verify a fingerprint
// Returns -1 if failed, otherwise returns the ID of the matched fingerprint
int getFingerPrint()
{
    int p = finger.getImage();
    if (p != FINGERPRINT_OK) return -1;
    p = finger.image2Tz();
    if (p != FINGERPRINT_OK) return -1;
    p = finger.fingerFastSearch();
}

```

**Figure 13.** Snippet of code 2.

```

    if (p != FINGERPRINT_OK) return -1;
    // A match is found, return the ID of the matched fingerprint
    return finger.fingerID;
}

```

**Figure 14.** Snippet of code 3.

The code begins by including the necessary libraries and creating a SoftwareSerial object to establish communication with the fingerprint sensor.

An instance of the Adafruit\_Fingerprint class is created using the Adafruit\_Fingerprint(&mySerial) constructor.

The RELAY\_PIN and ACCESS\_DELAY constants are defined. RELAY\_PIN represents the pin number connected to the relay module, and ACCESS\_DELAY is the duration for which the relay remains activated when a fingerprint match is found.

In the setup() function, the code initializes the serial communication with the fingerprint sensor by calling finger.begin(57600). It then verifies the password of the fingerprint sensor using finger.verifyPassword(). If the verification fails, the code enters an infinite loop to prevent further execution.

The loop() function is where the main logic of the code resides. It continuously checks for a fingerprint match by calling the getFingerPrint() function.

Inside the getFingerPrint() function, the code captures an image of the fingerprint using finger.getImage(). If the image capture is successful (FINGERPRINT\_OK), it converts the image to a template using finger.image2Tz(). Next, it performs a fast search for a matching fingerprint in the stored templates using finger.fingerFastSearch().

If a match is found (FINGERPRINT\_OK), the function returns the ID of the matched fingerprint using finger.fingerID. If no match is found, it returns -1.

Back in the loop() function, if getFingerPrint() returns a valid fingerprint ID (not -1), it means a match was found. The code activates the relay by setting the RELAY\_PIN to LOW to grant access. It then waits for the specified ACCESS\_DELAY duration before deactivating the relay by setting RELAY\_PIN to HIGH.

Finally, there is a delay of 50 milliseconds before the code starts another iteration of the loop.

In summary, the code initializes the fingerprint sensor and verifies its password. It then continuously checks for a fingerprint match and, if found, activates the relay to grant access for the specified duration. The `getFingerPrint()` function captures and verifies the fingerprint, returning the ID of the matched fingerprint or -1 if no match is found.



## **5. WORKING PROCEDURES**

Before connecting the components, information about all the components was studied carefully from the datasheets.

Before the connection of the components, the fingerprints were saved and uploaded to the Arduino board. To do so, the Arduino board was connected to the PC with a USB cable. Then the Adafruit fingerprint sensor library was installed. Then the enroll program was uploaded and the serial monitor was opened. After that COM8 was selected. Then my 3 fingers were placed respectively. Those fingers needed to be placed twice for the confirmation. Then the program was uploaded to the Arduino board. Then in the main program, a program was written to control the electronic lock. Necessary functions which are needed to perform the whole system were put in the program. Then the program was uploaded again. Finally, the Arduino was disconnected from the computer.

For the convenience of the connection work, the whole working procedures were divided into 5 steps.

First, the sensor was connected with the Arduino board. But before the datasheets of both the components were studied carefully. The VCC pin of the fingerprint sensor was connected to the 5V pin of the Arduino board. Then the GND pin of the fingerprint sensor was connected to the GND pin of the Arduino board. Next, the TX pin of the sensor was connected to pin number 2 of the Arduino board. After that the RX pin of the sensor was connected to the pin number 3 of the Arduino board.

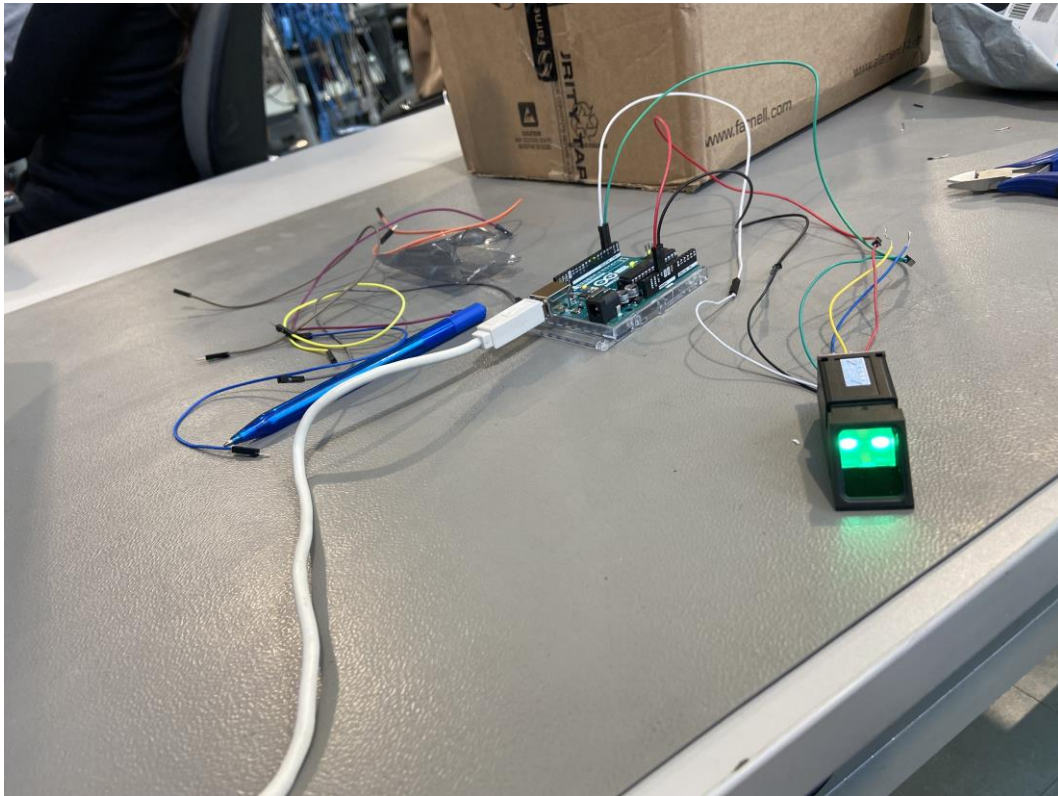

**Figure 15.** First step connection of my system.

So here the first step connection was done.

Second, now the relay is needed to be connected with the Arduino board. The VCC pin of the relay needed to be connected with another 5V pin. Here the breadboard helped for this point. Then the ground pin of the relay was connected to another ground pin of the Arduino board. After that the signal pin of the relay was connected to the digital output pin of the Arduino board.

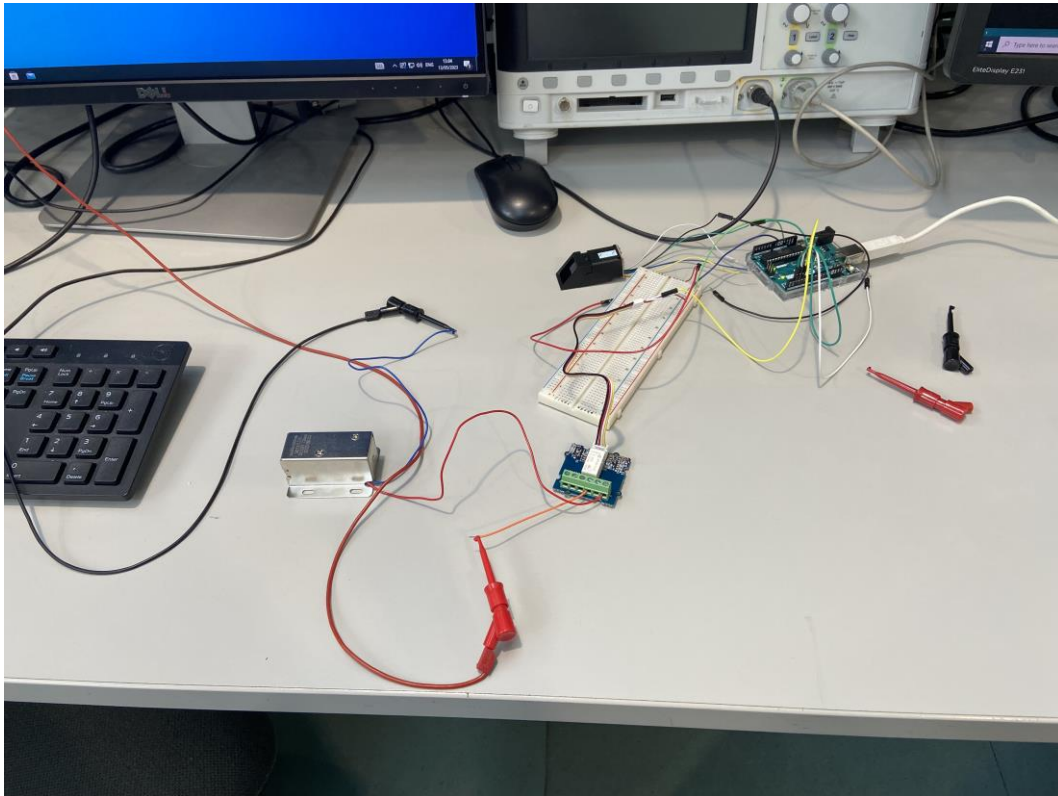

**Figure 16.** Second part connection of my system.

Third, this is the part for the connection of solenoid lock. One wire of the solenoid lock was connected to the common (COM) pin of the relay. Then the other wire from the solenoid lock was connected to the normally open (NO) pin of the relay. Fourth part is the connection of 12V adapter. The positive wire of the adapter was connected to the closed pin (NC) of the relay by me. Then the negative wire of the adapter was connected to the GND pin of the Arduino board.

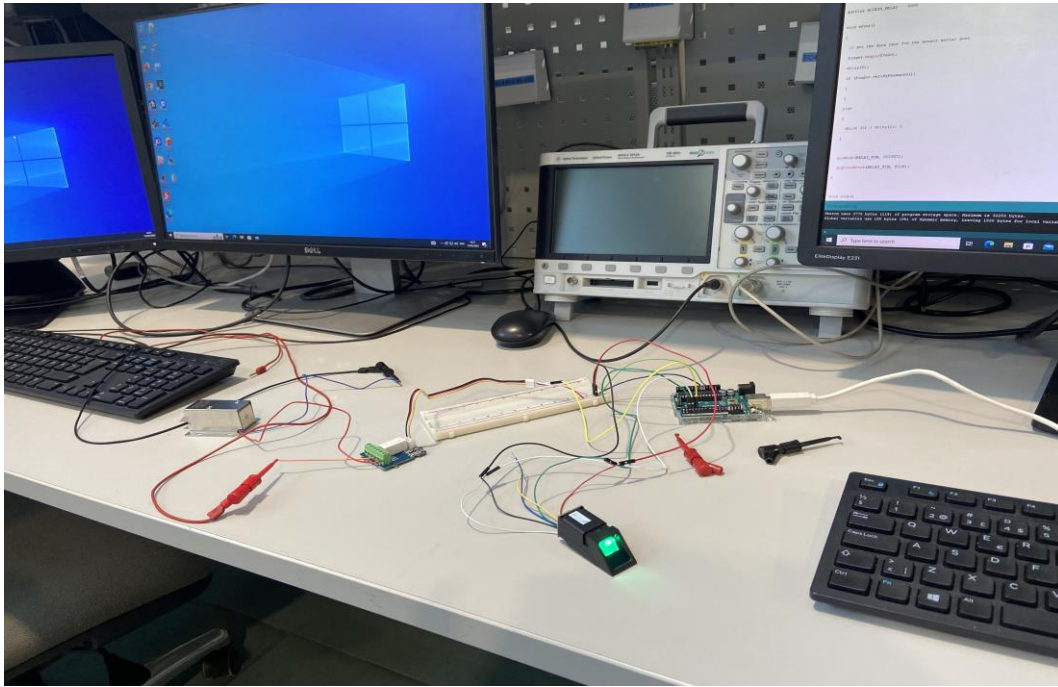

**Figure 17.** Final connection of the system.

Fifth, now it is the time to power up my system. For doing so, the 12V adapter was connected to the testing station of the University lab. As the code was already uploaded from the computer to the Arduino board. So, after the powering up, the system was ready to be tested. A problem during the implementation of the project was finding suitable components and their long delivery time. Difficulties were also encountered in connecting the sensor with the Arduino board.

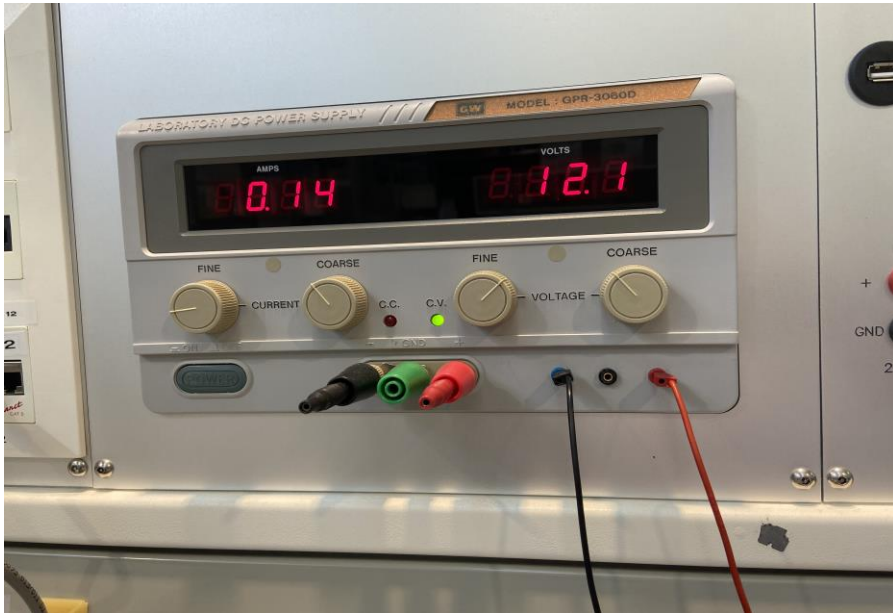

**Figure 18.** Power feeding to the system from the testing station.

### **5.1 Testing The System**

After completing all the connections, the system was powered up using the testing station of the university laboratory. 12V electricity was fed to the system. Then the fingerprint scanner started to illuminate its green light. The lock was in a closed position. So, to test the functionality, the finger was placed on the scanner, the fingerprint of which was already saved in the system. As the fingerprint matched, the lock opened. Then another finger was placed on the scanner which fingerprint was not saved before, then the lock remained lock.

This way the functionality of the system was tested.

## **6. EVALUATION OF THE FINGERPRINT DOOR LOCK SYSTEM**

### **6.1 Advantages**

Fingerprint door lock systems provide a high level of security compared to traditional lock systems. Each person has a unique fingerprint, making it extremely difficult for unauthorized individuals to gain access. It eliminates the risks associated with lost or stolen keys and the potential for unauthorized key duplication.

With a fingerprint door lock system, there is no need to carry keys or remember complex passwords or PINs. Your fingerprint is always with you, making it a convenient and quick method of access. It eliminates the troubles of searching for keys or fumbling with locks.

Fingerprint recognition technology has significantly advanced over the years, leading to highly accurate and reliable identification. Modern fingerprint sensors can capture even small details of a fingerprint, ensuring accurate recognition and minimizing false acceptance or rejection rates.

Many fingerprint door lock systems offer an audit trail feature that keeps a record of access attempts and successful entries. This feature can be valuable for security purposes, allowing to track who accessed the door and at what time. It provides a log of activity, which can be helpful for monitoring and investigation purposes.

Fingerprint door lock systems often have user management capabilities, allowing easy addition or removal of authorized users. It simplifies the process of granting or revoking access permissions, making it suitable for residential, commercial, and institutional settings where access needs may change frequently.

Fingerprint door lock systems are typically built to withstand daily use and harsh environments. They are designed with durable materials and components, ensuring longevity and reliability even with constant usage.

Fingerprint door lock systems can often be integrated with other security systems, such as alarms or surveillance systems, for enhanced security and control. They may also be compatible with smart home automation platforms, allowing integration with other devices and remote access control.

Fingerprint door lock systems come in various designs and styles, offering aesthetic appeal to complement the overall look of your door or property. They can be sleek, modern, and discreet, enhancing the visual appeal of your entryway.

These advantages make fingerprint door lock systems an attractive choice for those seeking a secure, convenient, and technologically advanced method of access control.

## **6.2 Disadvantages**

While fingerprint recognition technology has improved significantly, there is still a possibility of false rejection. Factors such as dirt, moisture, or changes in finger condition (cuts, scars) can impact the accuracy of fingerprint recognition, leading to occasional instances of legitimate users being denied access.

Fingerprint door lock systems can be more expensive compared to traditional lock systems. The technology involved, including the fingerprint sensor and associated hardware, adds to the overall cost of installation and maintenance. This cost may be a deterrent for those on a tight budget.

Installing a fingerprint door lock system may require professional assistance, especially if it involves integration with existing security systems or complex door configurations. The complexity of installation may increase the overall cost and time required to set up the system.

Fingerprint door lock systems typically require a power source to operate. They may rely on batteries or require a constant connection to an electrical outlet. In case of a power outage or battery failure, alternative means of access or backup power sources may be needed to ensure continuous operation.

Some individuals may have concerns about the collection and storage of their biometric data. Fingerprint door lock systems require the storage of fingerprint templates for recognition purposes. While reputable systems employ encryption and secure storage methods, privacy concerns regarding the misuse or hacking of biometric data remain a potential drawback for some users.

Fingerprint door lock systems typically have a limited user capacity, especially in lower-end models. This limitation may become an issue in scenarios where access needs to be granted to many individuals, such as in commercial or institutional

settings. Higher-end systems can accommodate more users but may come at a higher cost.

Like any electronic device, fingerprint door lock systems require regular maintenance and occasional troubleshooting. The sensors may need cleaning to maintain accurate readings, and software updates may be necessary to address security vulnerabilities or compatibility issues. Users should be prepared for occasional maintenance and ensure they have access to technical support if needed.

Fingerprint door lock systems may be susceptible to environmental factors such as extreme temperatures, humidity, or exposure to dust and dirt. It is important to choose a system that is designed to withstand the specific environmental conditions of its installation location to ensure optimal performance and longevity.

While the disadvantages exist, advancements in technology continue to address many of these concerns. It's essential to consider these factors and weigh them against the benefits when deciding whether a fingerprint door lock system is the right choice for specific needs and circumstances.

### 6.3 Cost Calculations

Here is the cost list for this system. All these purchases were kindly supported by the Vaasa University of Applied Sciences.

The cost calculation is shown in table 06.

Components	Description	Quantity	Price (Euro)
Fingerprint Sensor	SEN0188 Fingerprint Sensor, 5 Fingerprint Projects, Arduino Development Board	01	32,09
Nucleo Board	Arduino Uno	01	29,00
Solenoid Lock	MP001161 SOLENOID LOCK, 12VDC, 18W	01	16,74



Relay Module	Relay Module, Latching, 2 Coil, Arduino Board	01	6,99
Adapter	MP007780 AC/DC Power Supply, ITE, 1 Output, 24 W, 12 VDC, 2 A	01	11,96
	Total=		96,78

## 7. SAFETY MEASURES

Electrical safety guidelines were adhered to when working with components such as the Arduino board, fingerprint sensor, solenoid lock, and adapter. It was important to ensure proper grounding, avoid exposed wiring, and use appropriate insulation to prevent electrical shocks or short circuits.

High-quality components were chosen from reputable manufacturers to ensure reliability and safety. It was also verified that the components meet relevant safety standards and certifications.

Attention was paid to proper wiring and connections to prevent loose connections or exposed wires that could pose safety hazards. Appropriate connectors, terminals, and insulation were used to secure and protect the wiring.

In the testing station, a suitable power supply was selected, such as the 12V adapter, that meets the system's requirements and safety standards of the system. Proper voltage and current ratings were ensured.

The system components were enclosed, including the Arduino board and fingerprint sensor, in a suitable enclosure or housing to protect them from environmental factors and prevent accidental contact. The system was securely mounted to ensure stability and prevent dislodging or damage.

The future users will need to be educated in the safe and proper use of the system. Clear instructions will be needed on how to operate the system, avoid tampering, and address any potential risks associated with the solenoid lock or other moving parts.

A schedule needs to be established for maintenance to inspect, clean, and test the system periodically. The user will need to check for any signs of wear, damage, or malfunction and address them promptly to ensure continued safe operation.

The system's design, components, wiring diagrams, and safety considerations have been documented in detail. This information will be valuable for troubleshooting, future upgrades, and ensuring the safety of maintenance personnel.

By following these safety measures, a fingerprint door lock system was built that prioritizes the safety of users, meets regulatory standards, and operates reliably and securely.

## 8. CONCLUSION

In future, the project can be expanded to incorporate advanced security features such as multi-factor authentication, combining fingerprint recognition with other biometric modalities such as facial recognition or iris scanning. This would further enhance the security of the system and make it more difficult to bypass.

The fingerprint door lock system can be integrated into broader smart home systems, allowing users to control access and monitor their doors remotely using mobile apps or voice assistants. Integration with other smart devices such as surveillance cameras or alarm systems can create a comprehensive home security ecosystem.

By connecting the fingerprint door lock system to the cloud, users can remotely manage access permissions, monitor activity logs, and receive real-time notifications. Cloud integration also enables convenient remote unlocking and the ability to grant temporary access to guests or service providers.

The project can be extended to integrate with other Internet of Things (IoT) devices, such as motion sensors, smart lighting, or environmental sensors. This integration allows for automated actions, such as turning on lights when the door is unlocked or adjusting the thermostat based on occupancy.

The fingerprint door lock system can be adapted for use in commercial settings such as offices, hotels, or high-security facilities. It can provide secure access control, attendance tracking, and customizable access privileges for employees or authorized personnel.

The fingerprint sensor technology used in the project can be applied beyond door locks. It can be integrated into various applications such as secure storage lockers, personal safes, vehicle access systems, or even mobile devices for biometric authentication.

As fingerprint recognition technology continues to advance, future iterations of the project can incorporate improved algorithms and sensors to enhance accuracy, speed, and reliability. This would result in faster and more accurate fingerprint recognition, reducing false accept and reject rates.

Future developments can focus on improving the user interface, making it more intuitive and user-friendly. Additionally, allowing customization options for user preferences, such as adjustable sensitivity or personalized settings, can enhance the overall user experience.

AI algorithms can be utilized to continuously learn and adapt to user patterns, improving the recognition capabilities of the system over time. AI can also help detect anomalies or potential security threats, adding an extra layer of intelligence to the system.

Collaboration with security systems providers can open opportunities for partnerships, allowing for the integration of the fingerprint door lock system into existing security infrastructure or providing it as a bundled solution with other security products.

These future potentialities highlight the versatility and scalability of the fingerprint door lock system project, with opportunities to expand its functionality, enhance security features, and integrate it into broader technological ecosystems.

In conclusion, this thesis project has successfully designed and implemented a fingerprint door lock system using the Arduino Uno microcontroller. The system utilizes a fingerprint sensor module for user authentication and controls an electronic door lock for secure access. Through extensive testing and evaluation, the system has demonstrated its capability to accurately identify authorized users and prevent unauthorized access.

The project has highlighted the advantages of using a fingerprint-based authentication system, including increased security, convenience, and user-friendliness. By leveraging the uniqueness of an individual's fingerprints, the system provides a robust and reliable means of access control. Furthermore, the integration of the Arduino Uno microcontroller and other hardware components has allowed for a cost-effective and efficient solution.

Throughout the project, various technical aspects have been addressed, including the hardware setup, software programming, and system integration. The successful implementation of these components has resulted in a fully functional fingerprint door lock system.

Additionally, the project has explored the potential applications and future developments of the system. The integration with smart home systems, cloud-based access control, and compatibility with IoT devices open possibilities for expanding the system's functionalities and enhancing its usability.

It is important to note that while the fingerprint door lock system offers numerous advantages, it is not without limitations. Factors such as fingerprint spoofing and the reliance on a single biometric modality may pose potential vulnerabilities. Therefore, it is crucial to consider additional security measures and continuous monitoring to ensure the system's integrity.

Overall, this thesis project has provided valuable insights into the design, implementation, and potential enhancements of a fingerprint door lock system using Arduino Uno. It serves as a foundation for further research and development in the field of biometric authentication systems, home security, and access control. The project's success highlights the feasibility and practicality of utilizing fingerprint recognition technology for enhancing security and convenience in various settings.

In conclusion, the fingerprint door lock system project showcases the integration of hardware, software, and biometric technology to create a secure and efficient access control solution. The advancements made in this project contribute to the growing field of biometrics and highlight the potential for further innovation in this area.

## 9. REFERENCES

1. Fingerprint Sensor  
Accessed 11.05.2023. <https://www.farnell.com/datasheets/3216194.pdf>
2. Wikipedia
3. A. K. Jain, Y. Chen and M. Demirkus, "Pores and Ridges: High-Resolution Fingerprints Matching Using Level 3 Features," in IEEE Transactions on Pattern Analysis and Machine Intelligence, vol. 29, no. 1, pp. 15-27, Jan. 2007, Accessed 11.05.2023. doi: 10.1109/TPAMI.2007.250596.
4. Martin, M., Štefan, K., & Ľubor, F. (2018). Biometrics Authentication of Fingerprint with Using Fingerprint Reader and Microcontroller Arduino. TELKOMNIKA (Telecommunication Computing Electronics and Control), 16(2), 755. Accessed 12.05.2023. <https://doi.org/10.12928/TELKOMNIKA.V16I2.7572>
5. T. Chugh, K. Cao and A. K. Jain, "Fingerprint spoof detection using minutiae-based local patches," 2017 IEEE International Joint Conference on Biometrics (IJCB), Denver, CO, USA, 2017, pp. 581-589, accessed 12.05.2023. doi: 10.1109/BTAS.2017.8272745.
6. Arduino Uno  
Accessed 11.05.2023. <https://store.arduino.cc/products/arduino-uno-rev3>
7. Video tutorial  
[https://www.google.com/search?q=SEN0188+Fingerprint+Sensor+connection+image&tbm=isch&ved=2ahUKewiJhMrikvP-AhVOWioKHTjYAVwQ2-cCegQIABAA&oq=SEN0188+Fingerprint+Sensor+connection+image&gs\\_lcp=CgNpbWcQAzoECCMQJ1C-KFjDggFgkIoBaABWAHGA-gAF7iAGbGZIBBDY4LjGYAQcGAQgAQtn3Mtd2l6LWltZ8ABAQ&scient=img&ei=v\\_RfZM-moLM6EgwG4sIfgBQ&bih=904&biw=1920#imgrc=iLrV2uDhVorqCM](https://www.google.com/search?q=SEN0188+Fingerprint+Sensor+connection+image&tbm=isch&ved=2ahUKewiJhMrikvP-AhVOWioKHTjYAVwQ2-cCegQIABAA&oq=SEN0188+Fingerprint+Sensor+connection+image&gs_lcp=CgNpbWcQAzoECCMQJ1C-KFjDggFgkIoBaABWAHGA-gAF7iAGbGZIBBDY4LjGYAQcGAQgAQtn3Mtd2l6LWltZ8ABAQ&scient=img&ei=v_RfZM-moLM6EgwG4sIfgBQ&bih=904&biw=1920#imgrc=iLrV2uDhVorqCM)
8. Relay Module  
Embedded Computers, Education & Maker Boards> Arduino> Embedded Development Kit Accessories – Arduino  
Accessed 13.05.2023. <https://www.farnell.com/datasheets/3752244.pdf>
9. Adapter  
Accessed 13.05.2023. <https://www.farnell.com/datasheets/3752244.pdf>
10. Youtube  
<https://www.hackster.io/diyprojectslab/diy-fingerprint-door-lock-system-040249>