Precast Concrete Fabrication Process Improvement Through BIM-Based Paperless System Implementation.

Master Thesis

Master of Science in Construction and Real Estate Management

By

Ahmed Ali

Berlin-Helsinki

30.07.2021

1st Supervisor: M. Arch. Eric Pollock, Metropolia University of Applied Sciences

2nd Supervisor: Prof. Dr.-Ing. Dieter Bunte, Hochschule für Technik und
Wirtschaft Berlin

3rd Supervisor: Sakari Lahti, Trimble Inc. Finland

Thesis Title	Precast Concrete Fabrication Process Improvement Through BIM-Based Paperless System Implementation.
Universities	HTW Berlin University of Applied Sciences Metropolia University of Applied Sciences, Helsinki Finland
Program title	International Master of Science in Construction and Real Estate Management (CONREM)
Thesis committee	
Chairperson	Prof. Dr.-Ing. Dieter Bunte, Professor in the School of Engineering (Faculty 2: Technology and Life) at HTW Berlin university.
First Supervisor	M. Arch. Eric Pollock, Lecturer, School of Real Estate and Construction, Metropolia University of Applied Science.
Second supervisor	Prof. Dr.-Ing. Dieter Bunte, Professor in the School of Engineering (Faculty 2: Technology and Life) at HTW Berlin university.
Third supervisor	Eng. Sakari Lahti, Product Manager - Precast Design & Detailing at Trimble Inc.
Author	Ahmed Ali
Submitted on	30-07-2021
HTW University student ID	S0572513
Metropolia University student ID	1913041



**Hochschule für Technik
und Wirtschaft Berlin**

University of Applied Sciences

Berlin University of Applied Sciences
Wilhelminenhofstraße 75A, 12459 Berlin, Germany
Tel. (030) 5019 - 0
Fax: (030) 5090 134
www.htw-berlin.de



Metropolia University of Applied Sciences
Myllypurontie 1, 00920 Helsinki, Finland
Tel. +358 40 193 7758
www.metropolia.fi



Trimble Inc.
Metsänpojankuja 1, Espoo, Finland
www.trimble.com

Acknowledgement

First, I would like to thank Allah (God) for giving me the strength and power to complete this study.

I would like to thank Metropolia University of Applied Sciences and HTW Berlin for providing me with the opportunity to participate in this Master's program. I have gained fresh knowledge, experience, and wisdom during my time as a student.

I want to express my deepest gratitude to my supervisors, Prof. Dr-Ing. Dieter Bunte, M. Arch. Eric Pollock and Eng. Sakari Lahti for their unwavering support and very insightful comments and suggestions. One of the key reasons for the study's success is their supervision and care.

In addition, I would like to thank Trimble for supervising my master's thesis and providing me with all of the necessary resources and information. Furthermore, I want to thank Donald Jordan for his ongoing advice, consultation, and support throughout the research.

I want to express my gratitude to SWECO company and PNC company for cooperating with me in this research. I want to especially thank Oystein Ulvestad (BIM Developer in SWECO) and Wiktor Rybus (BIM/VDC Coordinator in PNC) for their outstanding effort to contribute to this research by providing me with all the needed data and feedback used in the Randselva case study.

Finally, I must express my heartfelt gratitude to my family and friends for providing me with their unwavering support and continuous encouragement throughout my years of study. Without them, This accomplishment would not have been possible.

Thank you.

Conceptual Formulation



International Master of Science in Construction and Real Estate Management Joint Study Programme of Metropolia Helsinki and HTW Berlin

Date 22.05.2020

Conceptual Formulation

Master Thesis for Mr. Ahmed Ali

Student number: 572513

Topic:

Different BIM approaches for improving the precast construction system

Background

Precast construction is the system when a structural element such as column or beam is produced in a factory or yard inside a fabrication mould with mass production to cover a specific project and then these elements are cured and transported to the construction site for installation and adjustment process (Allen & Iano, 2019). The advantages such as speed, high-quality control, reducing waste of material, and flexibility (VanGeem, 2006), have many European countries such as Finland, merging Building information modelling (BIM) with the precast construction cycle in order to reach its full potential in production, coordination and cost-efficiency.

BIM is defined as a digital representation of a physical and functional representation of a facility. it combines eight different dimensions includes time, cost, quantity takeoff, coordination and safety (Smith, 2014).

Unfortunately, some countries such as Egypt are not achieving the full potential of the system because they are not implementing the BIM uses in the industry of precast. The benefits of implementation for BIM in Precast system will be discussed. A comparison of the non-use of BIM and the use of BIM will be included to realise if the use of BIM is more efficient. Challenges of implementation are stated through case studies from Europe and the Middle East with some suggested technique of solving the precast problems.

Methodology

Qualitative research method will be primarily used in the study. The study will be based on the literature review to discuss the advantages and different uses of BIM generally and specifically in the precast field. The advantages and background of the precast construction system, additionally, quantitative analysis through a questionnaire or/and interviews will be done on different companies from different part of the globe (Europe and the Middle East) to answer the research questions.

Research Questions

Q1 What is the level of Precast production used in the construction industry in Europe and the Middle East?

Q2 How can precast construction be developed using BIM?

Q3 What are barriers of BIM implementation for precast production in different countries?

Q4 How BIM System can be implemented in Egypt? And what are the benefits & challenges?



Time Scale

Activity	Start	End
Conceptual formulation 1st Draft	February 2020	March 2020
Conceptual formulation final Draft	March 2020	July 2020
Literature Review	July 2020	December 2020
Quantitative data through Questioner Europe part 1	May 2020	July 2020
Quantitative data through Questioner in Egypt	July 2020	September 2020
Quantitative data through Questioner in Europe part 2	January 2021	March 2021
Draft 1 of the master thesis	March 2021	May 2021
Draft 2 of the Master Thesis	May 2021	June 2021
Final Master Thesis Submission	June 2021	July 2021
Presentation Preparation	July 2021	August 2021

Resources

Library Website of the Metropolia University: <https://metropolia.finna.fi/>
 Google Scholar: https://scholar.google.com/schhp?hl=en&as_sdt=0.5
 Web of Science: <https://login.webofknowledge.com/>
 Elsevier Website: <https://www.elsevier.com/>

References

Allen, E., & Iano, J. (2019). Fundamentals of building construction: materials and methods. John Wiley & Sons.
 Smith, P. (2014). BIM & the 5D project cost manager. SELECTED PAPERS FROM THE 27TH IPMA (INTERNATIONAL PROJECT MANAGEMENT ASSOCIATION).
 VanGeem, M. (2006). Achieving Sustainability with Precast Concrete, PCI JOURNAL, January-February, pp. 42-61.

Signature of the Supervisor

For the
Chairperson of the Examination Board

19. APR. 2021
Received by faculty

of the **Programme** Construction and Real estate management
at the Hochschule für Technik und Wirtschaft

REQUEST TO CHANGE THE TITLE OF THE FINAL THESIS

Family Name: Ali First Name: Ahmed
 Telepho: +358466164614 Email: Ahmed.ali3@metropolia.fi
 Street: Linnoituksintie 10 k Postal Code/City: 00940 / helsinki
 1st Supervisor: Prof. Eric Pollock 2nd Supervisor: Prof. Dr.-Ing. Dieter Bunte

I wish to request for the following change to the title of my thesis.

Previous title:

Different BIM Approaches for improving the Precast Construction System

New title to be confirmed:

Precast concrete fabrication process improvement through BIM-based paperless system implementation.

Please note that changing the title of the final thesis does not constitute a rejection of the topic as defined by § 21, no. 2 of HTW's Examination Framework Regulations!

Agreement of the 1st examiner:

Eric Pollock

Agreement of the 2nd examiner:

Agreement of the examination board:

Dieter Bunte
 Hochschule für Technik und Wirtschaft Berlin
 Fachbereich 2 • Ingenieurwissenschaften
 -Technik und Leben
 Fachbereichsverwaltung
 Wilschke-Platz 75A • 12459 Berlin
 Postanschrift: HTW Berlin • 10313 Berlin
 Tel.: 030/5019-3435 • Fax: 030/5019-2128

*3rd sup.
Mr. Lehti*

Berlin, _____

Signature of the candidate



**International Master of Science in Construction and Real Estate Management
Joint Study Programme of Metropolia Helsinki and HTW Berlin**

Date 07.04.2021

Conceptual Formulation

Master Thesis for Mr. Ahmed Ali

Student number: 572513

Topic:

Precast Concrete Fabrication Process Improvement Through BIM-based Paperless System Implementation.

Background

Precast Construction is the system when a structural element such as column or beam are produced in a factory or yard inside a fabrication mould with mass production to cover a specific project, and then these elements are cured and transported to the construction site for installation and adjustment process (Allen & Iano, 2019). With its advantages, such as Speed, High-Quality control, and Flexibility (VanGeem, 2006), many European countries, such as Finland, merging Building information modelling (BIM) with the precast construction cycle to reach its full potential in production efficiency, quality and cost-efficiency.

BIM is defined as a digital representation of a physical and functional representation of a facility. it combines eight different dimensions includes time, cost, quantity take-off, coordination and safety (Smith, 2014). This thesis discusses implementing different BIM tools such as (3D annotation) to change the traditional precast concrete production process through a paperless system. Cost, productivity, and quality are the variables to be discussed. The study will be subjected to three different precast elements with different complexity to increase the outcome accuracy. The benefits of implementation for a BIM tool and the digitalization of the Precast system fabrication process will be discussed. A comparison of the non-use of digital instructions and their use will be included to realize if the effect of digitalization. Challenges of implementation are stated through case studies.

Methodology

The covid-19 situation introduced new limits and challenges to the methodology used in this thesis. A Qualitative research method will be primarily used in the study. The study will be based on the literature review to discuss the advantages and different uses of BIM generally and specifically in the precast field. The benefits and background of the precast construction system will be introduced. The fabrication process of digital implementation and its challenges will be covered. Different precast models will be used in quantitative analysis through a questionnaire or/and interviews on different companies from different parts of the globe to answer the research questions.



Research Questions

- Q1** What are the different BIM-based paperless system improvements to the precast concrete fabrication process? Moreover, what are the challenges of this implementation?
- Q2** How can the paperless system be integrated into the fabrication process?
- Q3** What is the difference in productivity rate, cost, and quality of the fabrication process after using a paperless system?
- Q4** What is the different effect of integrating paperless systems on simple, moderate, and complex precast units?

References

- Allen, E., & Iano, J. (2019). Fundamentals of building construction: materials and methods. John Wiley & Sons.
- Smith, P. (2014). BIM & the 5D project cost manager. SELECTED PAPERS FROM THE 27TH IPMA (INTERNATIONAL PROJECT MANAGEMENT ASSOCIATION).
- VanGeem, M. (2006). Achieving Sustainability with Precast Concrete, PCI JOURNAL, January-February, pp. 42-61.

Eric Pollock

Signature of the Supervisor

Abstract

Although precast concrete technology has flourishing advantages, there is still a massive space for improvement. A new direction towards full-scale BIM-based paperless projects is currently trending. With any new system or methods, challenges are generated.

This study discusses the BIM-based paperless system implementation in the precast concrete fabrication process through literature research and case studies. Different implementation methods, advantages, challenges, and recommendations for implementing the BIM-based paperless methods are discussed. Moreover, the literature provided a background for precast concrete technology and Building Information Modeling (BIM), including history, definitions, benefits, and challenges. A comparison is made to prove the literature research points through a case study of a full-scale drawing-less project in Norway. Furthermore, through the analysis of the questionnaire distributed to experts in the field of construction, the author understood the topic better.

Finally, a conclusion with recommendations is presented at the end. The main finding is that the BIM-based paperless system implementation has many advantages that will enhance the precast concrete technology. However, some challenges of this implementation surfaced. Those challenges can only be solved by developing the BIM-based paperless system through the cooperation of different organizations.

Key words: BIM, paperless, precast concrete, drawing-less, fabrication.

Table of Contents

Acknowledgement	III
Conceptual Formulation	IV
Abstract	IX
Table of Contents	X
Table of Figures	XIII
List of Tabulations	XVII
List of Abbreviations	XVIII
List of Symbols	XX
1. Introduction	1
1.1 Background.....	1
1.2 Paper Aim and Objective	2
1.3 Scoop Limitations	2
1.4 Research questions	3
1.5 Methodology	3
1.6 Structure of the Study	4
2. Precast Concrete Technology	6
2.1 Introduction	6
2.2 Definition of precast concrete technology	7
2.4 Precast concrete technology advantages	10
2.5 Precast concrete challenges.....	13
3. Building Information Modelling	15
3.1 History	15
3.2 BIM definitions	18
3.3 BIM usage and dimensions.....	19
3.4 Level of development and level of details in BIM	20

3.4.1 Level of Detail (LoD).....	20
3.4.2 Level of Development (LOD).....	21
3.5 BIM benefits.....	24
3.6 BIM challenges	26
4. Paperless System.....	28
4.1. Definition and history	28
4.2. Different BIM-based paperless system tools	30
4.2.1. Quality assurance	30
4.2.2. 3D modelling and 3D annotation.....	32
4.2.3. Paperless reinforcement production	35
4.2.4. 3D coordination and clash detection tools	36
4.2.5 Augmented reality tool	38
4.3. Advantages of implementing the BIM-based paperless system with the precast concrete system.....	39
4.4. BIM-based paperless system implementation challenges	40
5. Case Studies	41
5.1 Introduction	41
5.2 Randselva bridge case study.....	41
5.2.1 Project description.....	42
5.2.2 Drawing-less system implementation process.....	43
5.2.3 Results and findings	52
5.2.4 Complex precast element example	58
5.2.5 Discussion	62
5.2.6 Conclusion	63
5.2.7 Statement of recognition and acknowledgement.....	64
5.3 Survey	64

5.3.1 Survey design.....	64
5.3.2 Survey content	66
5.3.3 Survey validity	67
5.3.4 Survey reliability	68
5.3.5 Survey limitations	68
5.3.6 Analysis approach.....	69
5.3.7 Survey results, analysis and findings	69
5.3.8 Survey conclusion.	83
6. Conclusion and Discussion.....	85
Recommendations and Future Development.....	89
Declaration of Authorship.....	90
References	91
Appendix	99

Table of Figures

Figure 1: Structure and Methodology for the Master thesis	4
Figure 2: University of Helsinki's Porthania building (ELEMATIC & Eilola, 2020) copyright for ELEMATIC, with the approval of the author's use only.	7
Figure 3: Palace Hotel, Helsinki 1952 (ELEMATIC & Eilola, 2020) copyright for ELEMATIC, with the approval of the author's use only.....	7
Figure 4: precast concrete operation process (Peng & Pheng, 2011).	9
Figure 5: The precast concrete elements (Kumar et al., 2016).....	9
Figure 6: The development of BIM (Adopted from Latiffi et al., 2014).	15
Figure 7: Schematic diagram of the proposed GBM (Eastman & Siabiris, 1995).	17
Figure 8: BIM lifecycle (Fernandes, 2013)	20
Figure 9: Representation of three levels of detail, according to the component Lod grade (Fai & Rafeiro, 2014).....	21
Figure 10: Level of development (LOD) levels (Latiffi et al., 2015).	22
Figure 11: Different LOD of concrete Precast Structural Inverted T, adopted from (Alferieff & Bomba, 2019).....	24
Figure 12: An Illustration of clash detections via Building Information Modeling (Azhar et al., 2008). .	25
Figure 13: Categories of potential barriers adopted from (Tan et al., 2019).	27
Figure 14: Site team using an electronic device to view a BIM model in the construction site (Koseoglu & Nurtan-Gunes, 2018).	29
Figure 15: PDA-camera communication system (Ordóñez et al., 2008).....	31
Figure 16: Sample of the generated 3D model generated from the photogrammetry method (Dai & Lu, 2010).....	32
Figure 17: Clash detection between MEP system and secondary beam (Lee et al., 2019)	33
Figure 18: 3D model of a precast concrete beam shows the 2D detailing information or the rebars on Trimble Connect software (Thorsten et al., 2021)	34
Figure 19: Trimble Connect web view after enabling the 3D annotation tool, previewing the drawing information on the exact location in the model (Thorsten et al., 2021)	35
Figure 20: The required information in every stage and the lifecycle of the automated RFT fabrication from model to site (Jalali, 2018).	36
Figure 21: Solibri clash detection report with selecting of the clashed objects (by author)	37
Figure 22: WBS code inside the element property on the modelling software (Ratajczak et al., 2019).	39
Figure 23: Randselva bridge model (Copyrights for Sweco company with the permission of the author's use only).	42
Figure 24: BIM workflow (Copyrights for Sweco company with the permission of the author's use only).	44
Figure 25: Parametric design script and illustration of the relationship between components (Copyrights for Sweco company with the permission of the author's use only).	45

Figure 26: The custom-made curtain "A_E16_PART_INFO" shows the UDAs added for a column part of the Randselva bridge (Copyrights for Sweco company with the permission of the author's use only).	46
Figure 27: Randselva bridge model includes over 200 tendons (Copyrights for Sweco company with the permission of the author's use only).....	47
Figure 28: Expansion joint BIM-model combined with BIM-model of superstructure and abutment. (Copyrights for Sweco company with the permission of the author's use only).....	48
Figure 29: Randselva bridge has more than 200 000 rebars (Copyrights for Sweco company with the permission of the author's use only).....	48
Figure 30: Trimble SiteVision Tool used in Randselva bridge (Copyrights for Sweco company with the permission of the author's use only).....	49
Figure 31: BIM- Station at the construction site (Copyrights for Sweco company with the permission of the author's use only).	49
Figure 32: The four primary purposes for using BIM models at the construction site (Copyrights for Sweco company with the permission of the author's use only).....	50
Figure 33: Bar binding list created automatically from Solibri model (Copyrights for Sweco company with the permission of the author's use only).....	51
Figure 34: Properties of the rebar data, including the needed information (Copyrights for Sweco company with the permission of the author's use only).....	51
Figure 35: Rebar label system (Copyrights for Sweco company with the permission of the author's use only).....	52
Figure 36: Steps marked in colours in a printed drawing and the BIM model (Copyrights for Sweco company with the permission of the author's use only).....	53
Figure 37: Using UDAs (user-defined attributes) shows different construction sequences (Axis 3: segments 01 and segments 02 phases) (Copyrights for Sweco company with the permission of the author's use only).	54
Figure 38: The drawing detail (right) and the 3D-BIM model perspective (left) (Copyrights for Sweco company with the permission of the author's use only).....	54
Figure 39: Digital mock-ups have replaced traditional 1:1 construction-site mock-ups (Copyrights for Sweco company with the permission of the author's use only).....	55
Figure 40: Augmented reality steel reinforcement illustrated in its location at the site (Copyrights for Sweco company with the permission of the author's use only).....	56
Figure 41: Augmented reality for the bridge location illustrated in its correct coordinates at the site (Copyrights for Sweco company with the permission of the author's use only).	56
Figure 42: Site team member using SiteVision to visualize the column alignment on-site (Copyrights for Sweco company with the permission of the author's use only).....	57
Figure 43: The complex corner foundation (precast concrete unit) in the construction site after casting (Copyrights for Sweco company with the permission of the author's use only).	59
Figure 44: 2D drawings of the same precast unit illustrating the high complexity of the design and shapes (Copyrights for Sweco company with the permission of the author's use only).	59

Figure 45: The precast concrete model viewed on Solibri, implemented from Tekla Structures (Copyrights for Sweco company with the permission of the author's use only).	59
Figure 46: Clash-free reinforcement illustration on the Solibri model (Copyrights for Sweco company with the permission of the author's use only).	60
Figure 47: showing the first stages of reinforcement assembly by selecting specific elements to show from the order list on the right side (Copyrights for Sweco company with the permission of the author's use only).	60
Figure 48: showing the following stages of reinforcement assembly by selecting more elements to show according to its order from the right side (Copyrights for Sweco company with the permission of the author's use only).	61
Figure 49: Corner precast concrete unit steel cage (Copyrights for Sweco company with the permission of the author's use only).	62
Figure 50: Pie chart showing the different fields of construction related to the participants	70
Figure 51: Pie chart illustrating the different roles of the survey participants with the related percentage of each position.	71
Figure 52: Pie chart showing the participants country of residence with the related percentage for each country.	72
Figure 53: Pie chart illustrating the different years of experiences for the survey participants	73
Figure 54: Pie chart showing the percentages of each company size related to the participants.	73
Figure 55: Pie chart illustrating the different age group percentages of the participants	74
Figure 56: Bar chart showing the participants answers related to the improvement on cost, quality and productivity.	75
Figure 57: Bar chart showing the participants answers related to each process.....	76
Figure 58: Bar chart showing the participants answers related to the complexity of elements and level of improvement.	77
Figure 59: Bar chart showing the participants answers related to the reasons for not using BIM-based paperless technology.....	78
Figure 60: Bar chart shows the percentage of the participants who prefer or don't prefer using the BIM-based paperless system.....	79
Figure 61: Bar chart showing the percentage of the different answers of the participants regarding the current status for an external process and if it requires a paper document or drawing usage.	80
Figure 62: Bar chart showing the percentage of the participants' different answers regarding the external process need for paper-based usage.....	80
Figure 63: Bar chart showing the different counts and percentages of the software(s) used by the participants.	81
Figure 64: Bar chart showing the participants answers for the different processes that use the BIM-based paperless technology at the moment.....	81
Figure 65: Bar chart showing the percentage of the participants' different answers regarding their organization providing a digital-driven infrastructure for fabrication.....	82

Figure 66: Bar chart showing the percentage of the participants' different answers regarding their organization providing information panels or mobile devices for workers.....	82
Figure 67: Bar chart showing the percentage of the participants' different answers regarding the number of years needed for widely accepting the paperless system.....	83

List of Tabulations

Table 1: Comparison between precast technology and traditional methods (by author)	12
Table 2: LOD different grades definitions and examples according to BIMForum (Alferieff & Bomba, 2019).....	23
Table 3: User-defined attributes used in the E16 Randselva project (Copyrights for Sweco company with the permission of the author's use only).....	46
Table 4: The weight corresponding to every answer according to the improvement related questions.	65
Table 5: The weight corresponding to every answer according to the relation related questions	65
Table 6: The weight corresponding to every answer according to the usability related questions	66
Table 7: Cronbach's Alpha calculation extracted from SPSS software.....	68
Table 8: Detailed rank given to the field of construction related to the precipitants.....	70
Table 9: The survey participants role ranks and percentages	71
Table 10: Detailed rank with the percentage of each country that participated in the survey.....	72
Table 11: Rank for years of experience percentage for the survey participants	73
Table 12: The different age group rank and percentage	74
Table 13: shows the count of the participant's answers and the related RII and Rank for every element.	75
Table 14: Shows the count of the participant's answers and the related RII and Rank for every process.	76
Table 15: Shows the count of the participant's answers and the related RII and Rank for every element according to its complexity level.....	77
Table 16: Shows the count of the participant's answers and the related RII and Rank for every reason related to not using BIM-based paperless technology.	79
Table 17: Shows the count of the participant's answers and the related RII and Rank for every phase usage of the BIM-based paperless system.	82

List of Abbreviations

2D	Two-dimensional
3D	Three-dimensional
AEC	Architecture, Engineering, and Construction
AIA	American Institute of Architects
AR	Augmented reality
AR4C	Augmented reality for construction
BCF-files	BIM Collaboration Format Data
BDS	Building Description System
BIM	Building Information Modelling
BPM	Building Product Model
BVBS	BundesVereinigung der BauSoftwarehäuser
CAD	Computer-Aided Design
CDE	Common data environment
CIFE	Center for Integrated Facilities Engineering
DQA	Dimensional Quality Assurance
GBM	Generic Building Model
GLIDE	Graphical Language for Interactive Design
IFC	Industry Foundation Classes
LBMS	Location-based system
LOD	Level Of Development
LoD	Level of Detail
LOG	Level Of Geometry
LOI	Level Of Information
M2	Meter square
M3	Meter cube
MEP	Mechanical, Electrical, and Plumbing
NIBS	National Institute of Building Sciences
NPRA	Norwegian public roads administration
PAS	British publicity available specification
QC	Quality Control
QTO	Quantity Take-Off
RFI	Request For Information

RFT	Steel Reinforcement
RII	Relative Importance Index
UDA	User-Defined Attributes
WBS	Work Breakdown Structure

List of Symbols

Σ	Summation
=	Equal
\times	Multiply
\div	Divide
%	Percentage

1. Introduction

1.1 Background

Previously, blueprints and sketches were used to convey a particular construction plan (Kravchenko, 2020). The primary method of data storage, communication, and exchange of information inside and outside an organization is paper (Mushhad et al., 2009). Replacing the paper system was not the primary goal of any company, but having higher productivity to enhance customer satisfaction is always one of the main goals (Djassemi & Sena 2006). The term paperless system related to construction does not have many definitions as it is not widely used. One of the few definitions of paperless construction is using electronic software(s) for managing contracts, managing and modifying drawings, viewing submittals and inspection reports (Hackman et al., 2004).

Precast construction's primary goal is to manufacture building materials in a productive work environment with access to specialist skills and tools. The aim is to save money and time on the job site while improving efficiency and consistency (Kumar, Patterson, & Jain, 2016). In the old days, the production of precast concrete elements took place using timber moulds that proved afterwards that it has weak durability for repetition work (Yee & Eng, 2001). In the mid-2000, the Architecture, Engineering, and Construction (AEC) industry integrated BIM efficiently in construction projects (Latiffi et al., 2014). AEC developed different computer-aided design (CAD) applications to Achieve the level of the BIM tools existing today.

Regardless of all precast concrete technology advantages, the precast concrete system faces challenges in the construction industry (Sacks et al., 2004). Precast concrete challenges depend on factors, including the country where the system is implemented, different precast concrete phases (e.g., design, production, and erection), and building complexity.

Building Information Modelling (BIM) is a model that has all the necessary data and information of a building to support all life cycle phases of construction. This model can be accessed effectively by computer programs. The structure and its components and

properties information are included in this model, such as materials used, functions, and procedures for the building's lifecycle (Underwood & Isikdag 2009).

It can be said that the paperless system is replacing paper-based traditional methods using digital BIM-based models (drawings-less systems). It also includes the use of paperless drawings instead of paper-based drawings. This new definition is based on the fact that BIM is a computable description of the building's physical properties created by digital technology (National BIM Standard Project Committee, 2007). Another reason for this definition is the relation of electronic or computable software with the BIM-based paperless systems. With this connection between the paperless system and BIM, it can be said that any digital use of BIM tools on an electronic device to replace the conventional paper system in order to achieve or improve a specified aim is a BIM-based paperless usage.

1.2 Paper Aim and Objective

Precast concrete technology is facing many challenges by not implementing the BIM-based paperless technology. This study's primary focus is to investigate the different improvements and challenges of the BIM-based paperless system implementation on the precast concrete fabrication processes to overcome its challenges. Another important aim of the study is to analyse the enhancement due to this implementation on cost, quality, and productivity; furthermore, the impact of this integration on the complex, moderate and simple elements. Finally, the study also investigates the different methods of implementing the BIM-based paperless system in the precast and construction fields.

1.3 Scoop Limitations

The study covers the improvements and challenges of using the BIM-based paperless methods in the fabrication process only, despite its significant impact on the installation and design process. The steel reinforcement assembling process, connection embedding and details, and concrete properties are not mentioned in this study despite their importance. Moreover, for more focus on the study topic, the logistics process and its improvement through BIM-based tools are left out.

The practical way of having an actual result from a field experiment was hard to obtain due to the Covid-19 situation. The data collected relied on three primary sources: literature, Randselva Bridge case study, and the survey.

1.4 Research questions

Q1 What are the different BIM-based paperless system improvements to the precast concrete fabrication process? Moreover, what are the challenges of this implementation?

Q2 How can the paperless system be integrated into the fabrication process?

Q3 What is the difference in productivity rate, cost, and quality of the fabrication process after using a paperless system?

Q4 What is the different effect of integrating paperless systems on simple, moderate, and complex precast units?

1.5 Methodology

The study methodology is based on using different methods to answer the study research questions using the following stages:

Stage 1: In-depth literature review to cover the scope of work's main topics, including their history, background, advantages and challenges. Moreover, to answer research questions one and two.

Stage 2: Intensive qualitative analysis through a case study for an actual project using a drawing-less BIM-based system in Norway. The author developed a proper understanding of the drawing-less BIM-based system implementation through the design and construction stages. Furthermore, the author discussed the advantages and challenges of this implementation with a general understanding of its effect on the quality and productivity processes and complex elements.

Stage 3: Comprehensive analysis through a survey distributed on experts in the field of construction to validate the literature and the case study findings, in addition to answering research questions one, two, three and four.

Stage 4: A conclusion to be conducted based on all the previous stages to summarize the study findings and provide recommendations for further development.

In conclusion, the research questions were answered from different chapters following the methodology presented, as illustrated in Figure 1.

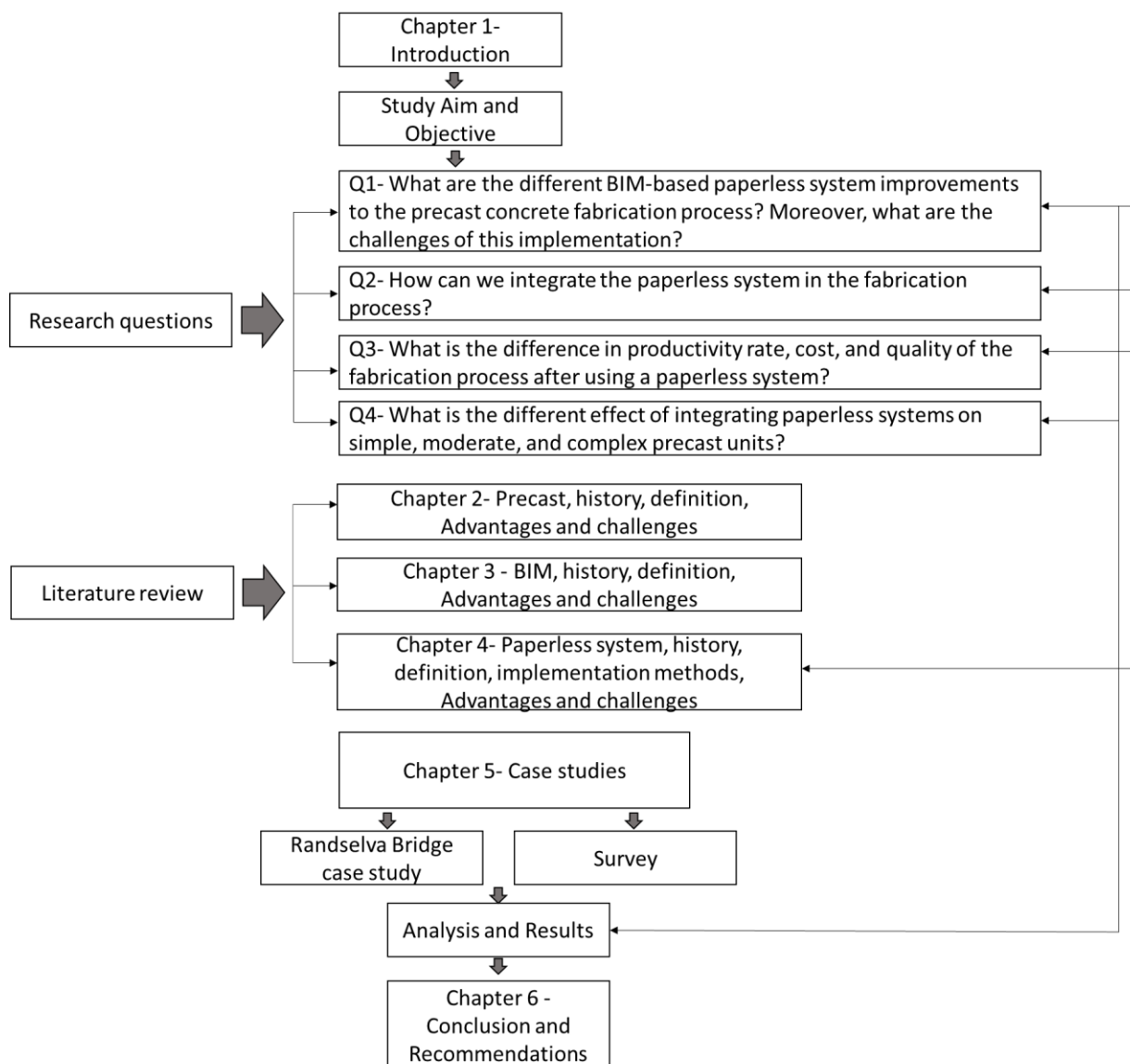

Figure 1: Structure and Methodology for the Master thesis.

1.6 Structure of the Study

Chapter 1: includes a background introduction on the study, study aim and objective, research questions, and methodology.

Chapter 2: discusses the history of precast concrete technology, definitions, advantages and challenges.

Chapter 3: includes intensive literature on BIM, discussing its development and different definitions. Moreover, it discusses the important and related concepts, advantages and challenges.

Chapter 4: discuss the BIM-based paperless system implementation methods. Furthermore, it provides a solid understanding of the topic and its related advantages and challenges.

Chapter 5: includes a case study on a BIM-based drawing-less project in Norway. This case study provides a detailed understanding of the method of implementation, benefits and challenges. Moreover, it contains a survey analysis and results that answer the research questions and validate the findings from the literature and the first case study.

Chapter 6: summarize the previous chapters and includes recommendations to be considered in future development.

2. Precast Concrete Technology

2.1 Introduction

It was always clear for contractors that the traditional cast in situ construction system was inefficient. Some of the reasons for this understanding are the increase in the labour cost due to poor transportation management and inadequate management of materials, tools, equipment transportation to the job site, and the massive amount of waste of all kinds. Untidiness, dust, air pollution, and noise produced from the in-situ construction site activities caused a lousy environment for the people living in the surrounding areas and the environment. Because of the high land values and the limitation of storage areas, extra trips to deliver all the materials needed for the construction and the tools were needed. These trips created a massive loss of time and traffic problems. In the year 2050, it is estimated to have 67 % of the world population living in large cities. This vast percentage means more construction and, therefore, more traffic jams and air contamination (Yee & Eng, 2001).

On the other hand, precast construction technology's primary goal is to manufacture building materials in a productive work environment with access to specialist skills and tools. This construction method saves money and time on the job site while improving efficiency and consistency (Kumar et al., 2016). In the old days, the production of precast concrete elements took place using timber moulds that proved afterwards that it has weak durability for repetition work (Yee & Eng, 2001). After an interview with ELEMATIC company discussing the history and the use of precast concrete in Finland. They presented that In 1952 Finland started to use precast concrete technology. The first precast skeleton was the university of Helsinki's Porthania building, as shown in Figure 2, and the first precast façade was the Palace Hotel in 1952, as illustrated in Figure 3 (ELEMATIC & Eilola, 2020).

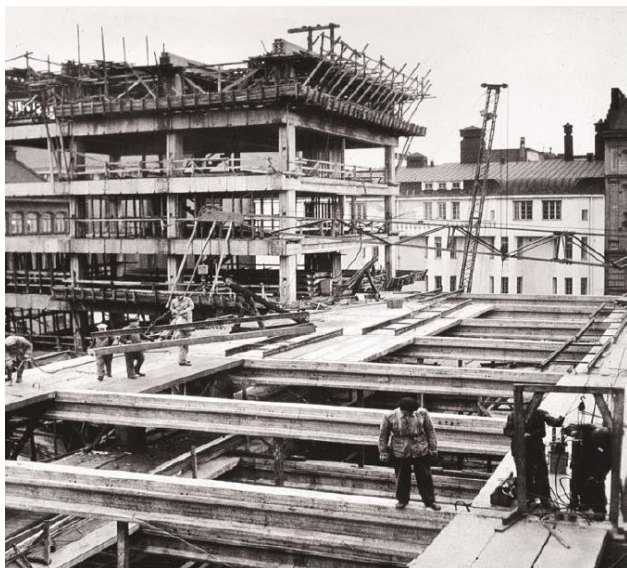

Figure 2: University of Helsinki's Porthania building (ELEMATIC & Eilola, 2020) copyright for ELEMATIC, with the approval of the author's use only.



Figure 3: Palace Hotel, Helsinki 1952 (ELEMATIC & Eilola, 2020) copyright for ELEMATIC, with the approval of the author's use only.

2.2 Definition of precast concrete technology

Different precast elements (e.g., wall panels, columns, beams, stairs, and slabs) are fabricated in a controlled environment in factories with proper operational and storage spaces. Precast components are manufactured with high strength and high-quality concrete in steel moulds. After the production process of the precast concrete elements, they are temporarily stored and then transported to the construction site for the final installation process (Yee & Eng, 2001). The prefabricated construction term refers to structures in which most structural elements are assembled and manufactured in factories or yards closer to the construction site. Furthermore, those elements are then transported to the construction site for installation or erection and used to create buildings in a brief time (Murari & Joshi, 2017). The precast construction process is also defined as the process that takes place in a controlled facility or factory where varied materials are mixed to produce a concrete element that is a part of the installation process of the structure (Murari & Joshi, 2017).

Precast concrete is a construction process in which concrete is cast in reusable moulds and cured in a regulated environment before being transported to the job site, elevated, and set in place. Structural elements (such as beams, columns, and slabs) and architectural facades are the two primary precast concrete applications (Kaner et al., 2008).

Prefabrication is defined as the process of producing industrialized or precast construction elements of different dimensions in a factory before delivering them for installation at the construction site. On-site and off-site are the two construction methods used in precast concrete fabrication. On-site is the method where precast concrete elements are produced in a production yard within the construction site that saves time and cost due to eliminating the transportation phase. Off-site is the standard precast production method that takes place in a factory and then transporting the precast concrete elements to the construction site for erection. The last method is the composite method of a cast in situ construction mixed with using precast concrete elements for specific parts of the structure (e.g., precast concrete stairs or walls) (PRASAD & PRASAD, 2015).

2.3 Precast concrete phases and components

Before going into detail about the precast phases, the five main stakeholders in the precast concrete stages: the owner, architecture, structural engineer, production team, and finally, the installation team (Kaner et al., 2008). As shown in Figure 4, the precast concrete construction activities start with receiving raw materials, cleaning moulds, and fixing the moulds. Those activities can be considered pre-production activities. The production process activities include fixing rebars, then concreting, and finally curing, demolding, and repair (Peng & Pheng, 2011). After storage, the precast elements are transported to the construction site for the final installation process. After installation, precast concrete elements' life cycle may continue as reusable or recyclable elements after demolishing the original structure (VanGeem, 2006). Before the precast concrete elements' construction phase and erection phase, the planning and design phase occurs. The precast concrete elements' architecture design and structural analysis processes are similar to the cast in situ processes, considering some specific specifications for precast concrete elements (Polat, 2008).

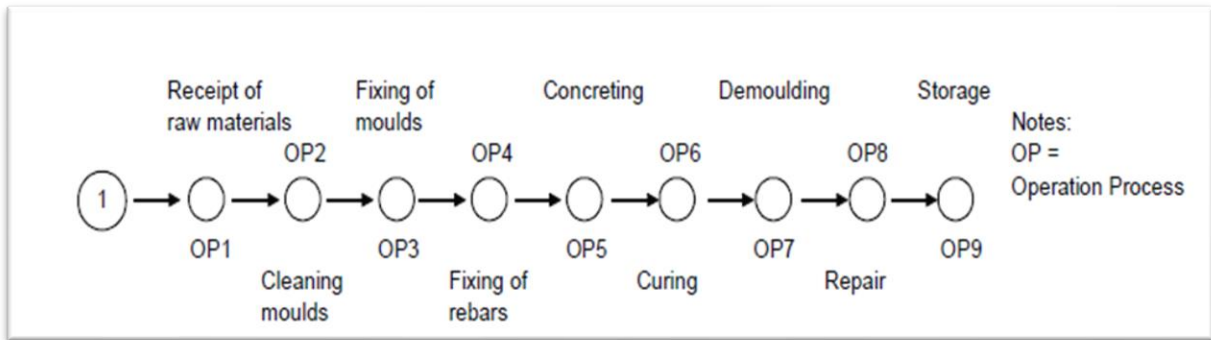

Figure 4: precast concrete operation process (Peng & Pheng, 2011).

The precast concrete casting yard is classified according to the use into four areas. The four regions are casting, storage for precast concrete units, storage for materials and tools, and roads for accessibility. In the casting area, the distance between moulds is designed to be enough for work carried out. The precast units are stored according to type with considering leaving proper spaces for handling. The precast yard is designed so that the casting and storage areas are opposite to each other to minimize the time needed for moving the units. Finally, the drainage system is an essential factor when designing the yard to avoid any untidiness and ease the yard cleaning process (Murari & Joshi, 2017). The precast concrete system is repetitive. The main precast components, as shown in Figure 5, are precast columns with corbels, precast slabs (e.g., hollow-core slabs), precast concrete beams (internal or external), precast wall panels, and precast staircases (Kumar et al., 2016).

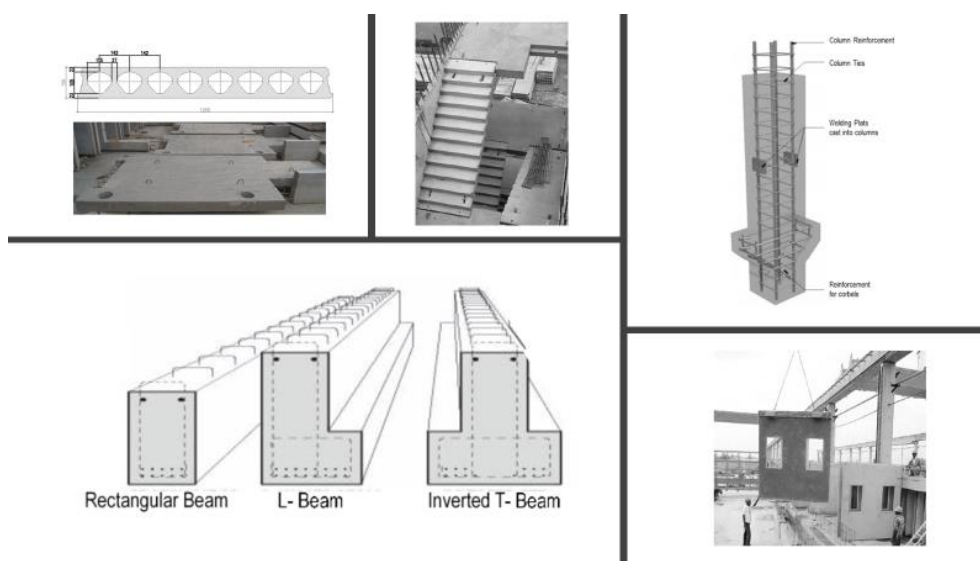

Figure 5: The precast concrete elements (Kumar et al., 2016).

In conclusion, the precast phases are similar to the traditional phases in the prefabrication phases. Planning and design are the typical phases with different approaches and methods according to the system used. The design phase produces the production and erection calculation, analysis, details, models, and drawings for fabrication, and the earlier stages take place in design offices.

However, In the construction phase, the precast concrete process starts in a factory or production yard near the construction site by ordering and receiving the raw materials. Then, the mould fabrication and assembly activities start. In parallel, the steel reinforcement cages are assembled and then installed in the inspected moulds for the steel fixation process before concrete pouring. First, the steel cage is examined, then the concrete pouring process starts, and the concrete element rest in the mould until it reaches the required lifting strength. Next, a crane or other fixed lifting tools are used to lift the precast concrete unit from the mould using then the units are transported to storage, where the curing process and repair works happen. After the curing process and when the element reaches the required strength for transportation, the units are transported by trucks to the construction location for the final erection process. The units are either lifted from the lorry to the installation coordinates directly or stored to be installed later. The last and the most critical activity in the erection process is the alignment process of the precast concrete unit according to the model allowed tolerance (By Author).

2.4 Precast concrete technology advantages

The precast concrete technology presents a wide range of advantages. Compared to any other construction system, the precast concrete system supplies better quality due to the controlled factory or production yard environment. Compared to the traditional method, the number of labourers included in the process is more petite (Nanyam et al., 2017). Having fewer players included in the construction cycle has benefits, such as better coordination, time planning, waste reduction, and improving the safety and health operations due to fewer operational activities on-site (Kumar et al., 2016). In the in-situ construction process, the elements need a duration for curing on site after the concrete pouring activity ends, which causes a waste of time and a more extended schedule. In precast concrete technology, the elements do not need a curing time on-

site after the installation process. As explained before, the curing happens in the factory, saving a massive amount of time on site. The savings are produced due to reusable formwork instead of using formwork for the whole structure (Nanyam et al., 2017).

Natural resources use is minimized due to the massive amount of savings in material. The benefits of reducing natural resource usage are reducing waste, low energy consumption, decreasing environmental emissions, and saving materials wastage. Having these methods of saving and advantages made precast construction a sustainable system in cost and time reduction (PRASAD & PRASAD, 2015). The materials used in the precast fabrication under the controlled environment have a constant temperature in cold and hot weather conditions with good insulation properties. Safety benefits do not end only at the safety of the construction site. Protection also includes the strength of the structural stability that prevents fire from spreading and has excellent resistance to most natural disasters and impacts (Dineshkumar & Kathirvel, 2015).

Precast structural units are manufactured in a managed plant environment and are installed in challenging climate conditions. The same challenging climate conditions will cause a delay in completion for the erection if steel or cast in situ methods are used. In general, the benefit of precast is that it lowers the total construction timeline and operating costs by allowing a quicker installation (Kumar et al., 2016). Another critical aspect of precast concrete is the variety of options in construction. This variety of options includes the ability to have different surface finishes, complex shapes, and different pigmented colours. Furthermore, with the ability to manipulate the mould and its surface, the fabrication process can produce precast concrete units with varying materials of characteristics tailor-made according to the client's request.

Furthermore, the stability of the precast concrete units throughout their life is essential. This stability is because precast concrete elements do not need any chemical additions to protect them against insects and rot. Moreover, in durability, the ancient Egyptian used precast elements that are still standing until our time. Finally, with the unique design options, the design can be perfected quickly to supply a durable structure that can last for decades (Dineshkumar & Kathirvel, 2015).

The precast construction system has advantages related to being a sustainable system. These advantages are related to the efficiency of the material used, durability, and resistance to noise, corrosion, fire, weather, hurricanes, flood, rain, and

earthquakes. The environmental advantages that the systems offer include reducing radiation and toxicity by supplying a barrier against them. Its production process requires less material due to the exact design method used with the minimum tolerance achieved by the quality control inspection (VanGeem, 2006). With the flexibility in design and better architecture layout, The system is faster and easier for erection with lower project cost and excellent quality control process (Polat, 2008).

Furthermore, the precast construction system saves energy, recycling materials by demolishing old precast buildings, reusing them again as a road base, or protecting shorelines. Another advantage of a precast unit is that the user can un-erect it and reuse it again on another site. One example is reusing a project fence for one place after it ends in another project due to the ease of erection and re-erection of the precast units (VanGeem, 2006).

Finally, it can be concluded that the main precast concrete system advantages in the following points (Priya & Neamitha, 2018):

- Compared to the traditional system, the precast concrete system is 20 % faster;
- Precast concrete units' quality is better because of the controlled environment production system;
- The project workforce is less compared to the traditional system;
- Erection and production speed are higher than the traditional system;
- Thermal insulation is better with lighter elements.

The author concluded the differences between precast technology and traditional methods in the following Table 1.

Items	Productivity	Quality	Work-force	Thermal insulation	Sustainability	Challenging weather conditions	Curing time
Precast Technology	High	High	Low	High	High	High workability	In production factory
Traditional Method	Normal	Normal	high	Low	Normal	Very low workability	On-site

Table 1: Comparison between precast technology and traditional methods (by author)

2.5 Precast concrete challenges

Regardless of all these advantages, the precast concrete system faces challenges in the construction industry (Sacks et al., 2004). Precast concrete challenges depend on factors, including the country where the system is implemented, different precast concrete phases (e.g., design, production, and erection), and building complexity. A case study was made in India to discover the difference between a 36000 square foot precast concrete building and a 4500 square foot traditional villa. A questionnaire was distributed to 50 different parties of the two projects to find the precast concrete adaptation challenges. In these small-scale projects, it was found out that the precast difficulties can be categorized into four main points (Nanyam et al., 2017).

The first point included operational and technical challenges. These challenges are the joint stability during the installation process, the need for massive equipment and storage yard for handling, the coordination between scheduling and delivery, location-related challenges, and complexity in implementing the MEP system. The second point focused on the end-user perspective. There was no cooperation or understanding of the system from the owner or the user side. Thirdly, challenges related to the project executor's skills. There was a massive lack of skilled workforce, insufficient experts, and a low level of knowledge about the know-how of the precast concrete system. The last and most crucial point is the design challenges. The continuous change of design and not having an updated drawing confused the production and erection teams, finally, the complexity of the precast technology methods (Nanyam et al., 2017).

The success of a construction system depends on a proper level of communication between stakeholders. Production and erection timelines are affected when manufacturers are not in contact with the designers at the project's early phases (Arditi et al., 2000). The production team's role is essential as they must follow the designer's drawings and details in the production process and deliver the product to the construction site on time (Polat, 2008). So, it can be concluded that the production phase is the connection between the design phase and the erection phase. The complexity and opacity of the design generate great confusion for the production team and cause a delay in the production and erection process (Arditi et al., 2000). The number of problems during the manufacturing and installation phases can be reduced as the parties in an industrialized building system interact more with a better communication tool (Polat, 2008). Another outcome of poor communication among parties is the design defect.

Design defects could be avoided in the production phase with better communication if the designer were connected to the production team during the first design stages (Polat, 2008). The main challenge that faces the precast concrete industry is the low communication standard between project parties (Priya & Neamitha, 2018).

Finally, the precast disadvantages can be concluded in the following points (Priya & Neamitha, 2018):

- For small structures, a precast concrete system has no cost-saving;
- Transportation problems are evident due to damaged units or the high cost of transportation for long destinations;
- Lack of knowledge about the implementation of the precast concrete system in countries;
- The precast concrete units crack pattern is the same as the traditional system, with no improvement;
- Lack of cooperation and inadequate communication between the project parties;
- A strong connection between the planning and the operation and maintenance; if the planning is not connected correctly with the other phases, it might cause future problems;
- The cost is more than the cost of the traditional system.

Finally, it can be noticed that even though the precast concrete system has advantages, it is not a perfect system yet. Moreover, one of the significant problems this system faces is communication; as was discussed, the production phase is the phase that connects both the design and the erection phase. This connection makes the production phase the most critical stage in the construction cycle. That is why any improvement in this phase will directly affect and enhance the entire process. The un-updated drawings, inconsistent information flow, complexity of design, design clashes, and the low level of collaboration between parties are solvable problems by implementing BIM-based paperless tools into the precast production phase. This implementation will improve the whole precast concrete cycle by increasing its efficiency and decreasing its challenges to a better and more complete system.

3. Building Information Modelling

3.1 History

In late 1970 a professor called Charles Eastman developed the Building Information Modelling (BIM) concept in Georgia Tech School of Architecture. Prof. Eastman noticed that the construction 2D drawings have a limitation about the building's overall visualization and lack of updated real-time Drawings according to the project's updated status. This development expanded different perspectives such as construction, the life cycle of a building, the design process, and its technology. Pre-construction, construction, and post-construction were the three main phases of BIM integration (Latiffi et al., 2014).

In the mid-2000, the Architecture, Engineering, and Construction (AEC) industry integrated BIM efficiently in construction projects (Latiffi et al., 2014). AEC developed different computer-aided design (CAD) applications to reach the BIM tools existing today. Following the same pattern, prominent CAD entrepreneurs such as Trimble and Graphisoft started to use the BIM concept in their products (Oli, 2017). The development of BIM stages starting from the Building description system (BDS) is illustrated in Figure 6.

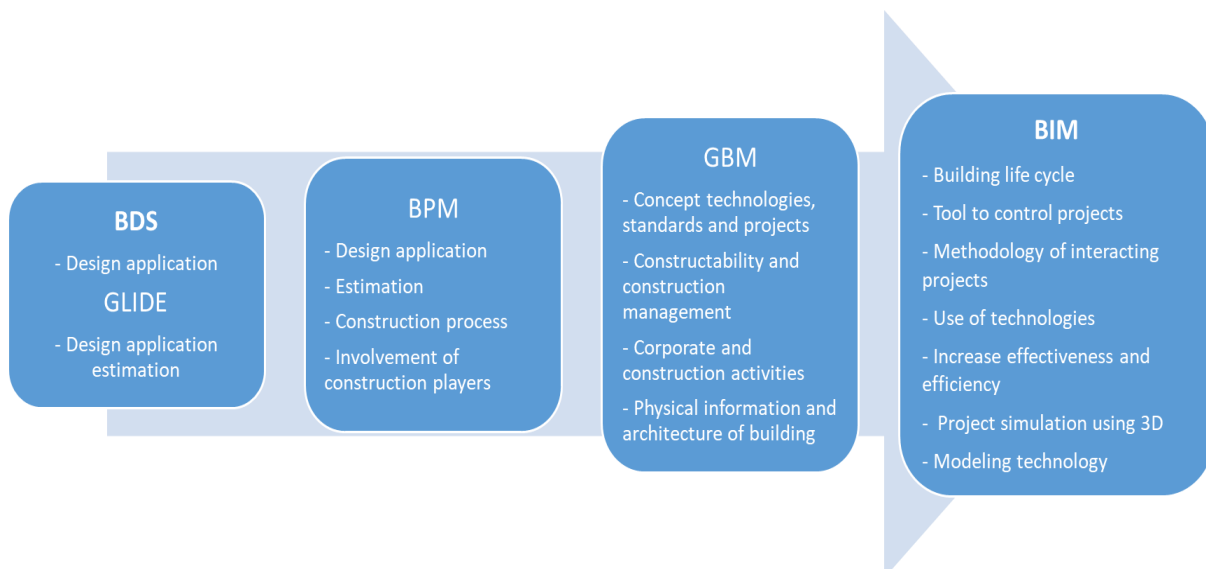

Figure 6: The development of BIM (Adopted from Latiffi et al., 2014).

BDS was the cornerstone of BIM technology's start (Dobelis, 2013). Prof. Eastman first introduced BDS, a computerized design software used in the three different

construction phases mentioned before. BDS system can store information in a database platform to be retrieved again when needed (Yin et al., 2020). BDS's primary purpose was to construct complex physical models using a computer for better understanding and replacing 2D drawings. The idea was to have a central software that explains the construction and design details of a structure (Eastman et al., 1975). The BDS system advantages include automatic clash detection and the capability to define and change a complex high number of different elements (Eastman et al., 1975).

Graphical Language for Interactive Design (GLIDE) was introduced in 1977 because the BDS system was subjected to technical limitations in the 70s. The main reason was that not all architects had access to a personal computer; therefore, they did not have the chance to get a grip on the software (Dobelis, 2013). GLIDE has many of the features in the BDS system, such as managing a vast number of complex elements and controlling their shapes. It adds to the earlier system a complete description of the objects and a method to relate them together (Eastman & Henrion, 1977). GLIDE's main goal was to improve the 2D generated drawings to be more accurate. It was formulated to be used as a tool to check the estimated data cost of the design (Latiffi et al., 2014).

In 1989, the Building Product Model (BPM) software was created (Latiffi et al., 2014). BPM is used through a data exchange format called Industry Foundation Classes (IFC). Using this format enables the software to create, manipulate and share the data quickly in the design stage. The data storage of BPM finds all the data from the fabrication or design process in one source with ease of access (Matipa et al., 2008). In addition to being a design application, BPM works in estimation and construction with different construction players' involvement (Latiffi et al., 2014). The BPM database has information on the design, planning, construction, and completion of the structure. Unfortunately, the BPM only focused on the products' information and did not integrate this information in construction management (Luiten et al., 1998).

Generic Building Model (GBM) was created to have better software in construction management. It represented physical and abstract information needed to model the first understanding of the structure and architecture. Also, it illustrated more details and more classifications for the structural model, as shown in Figure 7 (Eastman & Siabiris, 1995). Furthermore, GBM can define the relations in the model in operational methods.

These capabilities enhanced the project information system, making the project's cooperation more manageable (Latiffi et al., 2014).

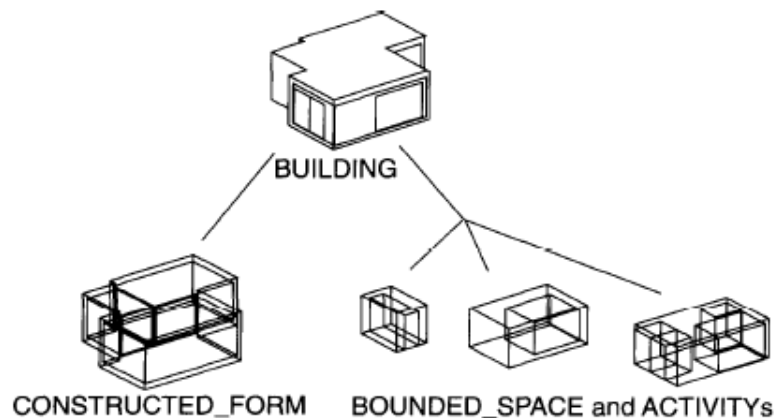

Figure 7: Schematic diagram of the proposed GBM (Eastman & Siabiris, 1995).

BIM was developed due to the continuous increase of the project's complexity and details. BIM was considered a model representing the static (entity properties) and dynamic (rules for entity assembly) aspects of a building, allowing data and behavioural modelling (Ameziane, 2000). It is said that BIM is one of the best-advanced improvements in the AEC field. Construction, planning, and fabrication processes are aided with all the data and details in these models (Eastman et al., 2011). BIM is also characterized as a tool that aids decision-making by presenting data related to a facility's physical characteristics in a computer-readable format. The data is saved in the BIM system to be reused in a structured manner during the facility's life cycle (Kaner et al., 2008).

It can be concluded that it all started when Professor Eastman in 1970 noticed that 2D drawings are inefficient in visualization and the updated status of the drawings. With the continuous increase of the design complexity and details needed for construction, finding a method to ease the different construction phases was necessary. The direction for the paperless system was always a method toward the future. Today, the BIM system has eight dimensions, including time, cost, quantity take-off, coordination, and safety. It was found that North America and Scandinavian countries are the leaders in developing BIM and using it, proving that by the massive increase between the year of 2007 till 2012 by 54% in North America (Smith, 2014).

3.2 BIM definitions

The definition of BIM is different from one researcher to another. BIM terminology does not have a specific description (Underwood & Isikdag 2009). BIM system is used in design, construction, facility management, and planning. Different users have a particular understanding of the system that serves their interests according to their use fields. In design, The digital representation of a project's physical and functional characteristics is known as BIM, showing the technologies and procedures used in the modelling process. However, for the construction phase understanding, BIM is used to simulate a project's operation and construction phase using a computer-developed model. On the other hand, facility managers consider BIM tools an innovative approach for operating and managing the building through various stages to enhance the building's overall performance. What is noticed is that The common terminology which is related to the BIM definition from multiple institutes and organizations in the building lifecycle (Abbasnejad & Moud, 2013).

One definition of BIM is that it is a model that can be accessed effectively by computer programs that has all the necessary data and information of a building to support all life cycle phases of construction. The structure and its components and properties information are included in this model, such as materials used, functions, and procedures for the building's lifecycle (Underwood & Isikdag 2009). Another definition of BIM is that it manages and uses information effectively at all stages of the construction process, from preparation to completion. This process is executed by exchanging and sharing data according to projects and procedures, emphasizing information interoperability during the construction lifecycle (Mohamed et al., 2019).

Furthermore, BIM is defined as managing all the needed information and tasks for an organization effectively, starting from the first phase of planning to design, construction, maintenance, and finally demolition (Abbasnejad & Moud, 2013). The National Institute of Building Sciences (NIBS) definition for BIM that it is a computable description of all the functional and physical properties of a facility and its associated project lifecycle data created using innovative digital technology. BIM is intended to be a source of information for the facility owner/operator to use and manage during the facility's lifecycle (National BIM Standard Project Committee, 2007).

One of the most promising advances in the AEC industry is BIM. More than one realistic virtual models of a structure are created digitally using BIM technology. The models support all the phases of the design process with greater control and analysis than the traditional methods. In addition, it supports the construction, procurement, and fabrication process by including all the needed data and geometry (Eastman et al., 2011). Finally, it can be concluded that BIM advantages are spread throughout the project life cycle from all these definitions. Different stakeholders' use makes the BIM system one of the most used systems in the construction industry. One standard information that all the stakeholders have in their definitions is that the BIM system has all the needed information for their use. Moreover, it defines the physical, functional, and geometrical details used in the building's life cycle. With such wide usage, the BIM system has many advantages over the traditional system in every phase discussed in detail in the following section.

3.3 BIM usage and dimensions

As discussed in the earlier section about BIM definitions, BIM is used in all the project lifecycle. To better understand the BIM benefits, the different BIM applications in the project phases and the BIM other dimensions must be explained. As illustrated in Figure 8, BIM usage is included in every stage of the project lifecycle. The BIM usage is starting from programming and conceptual design until the building's final demolition or renovation. It also includes the building operation, which takes the most consuming duration in the building lifecycle. Furthermore, various stakeholders use the BIM system in the project for different benefits. It provides them with precise and consistent detailed information and data needed for further modelling and related work (Fernandes, 2013).

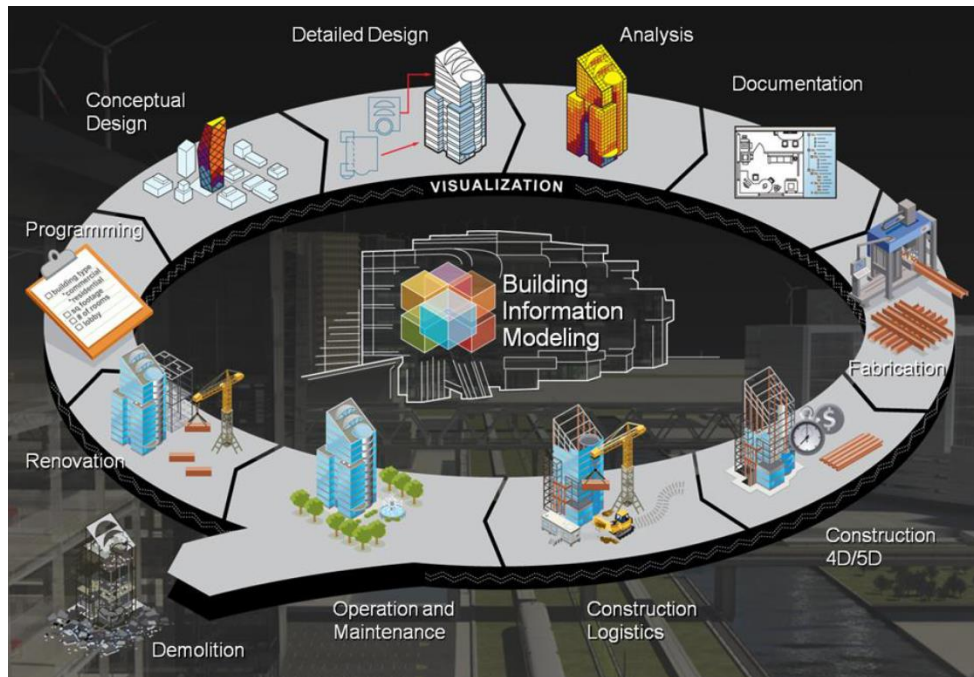

Figure 8: BIM lifecycle (Fernandes, 2013)

BIM dimensions exceed the 3D dimension of the object or building model with five more dimensions of time, cost, operation/procurement, sustainability, and safety, making the BIM system the only eight-dimensional system in the industry (Smith, 2014). A data exchange format needed to be developed with various usage to improve the information exchange efficiency between different BIM-based programs. IFCs were created by buildingSMART to be the data format used in BIM models exchange that any BIM software can access (Amoaha & Nguyenb, 2019).

3.4 Level of development and level of details in BIM

3.4.1 Level of Detail (LoD)

The terminology Level Of Development (LOD) is related to the level of details (LoD) (Lévy, 2011). VICO company introduced Lod terminology in 2004. This new concept aim was to enhance the information management included in the BIM models (Mavreli, 2018). LoD is defined as the number of details used in the building model components (Latiffi et al., 2015). According to VICO company, The level of detail acts as a coordination point for further details about the structure, level of details used, calculated, and planned. LoD offers a valuable guideline for the project's different stakeholders. Marveli

(2018) stated that the definition of the level of detail according to Trimble company is the way how the model appears.

As shown in Figure 9, LoD has different grades according to the component grade used in the modelling process; according to AEC (UK) protocol, the level of detail four grades are starting from Component grade 0 (G0) is called schematic LoD. It demonstrates a not-to-scale element without any dimension values and is usually used to indicate electric symbols. Component grade 1 (G1) is called a concept LoD. It shows the minimum level of details that makes the object knowable. G1 is created from plan material, as illustrated in Figure 9, of a white representation of a chair with shallow or preliminary dimensions. Component grade 2 (G2) is called defined LoD. It includes the element technical and descriptive data with suitable dimensions and 2D details enough for project use. It is designed well enough to define the type and material component of the element. Component grade 3 (G3) is called rendered LoD. It includes all grade 2 characteristics in addition to 3D representation, and it is commonly used in 3D views when a rendering requires an element to be close to the rendered shot (AEC, 2012).

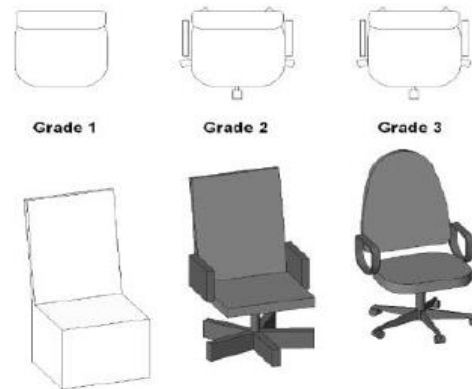

Figure 9: Representation of three levels of detail, according to the component Lod grade (Fai & Rafeiro, 2014).

3.4.2 Level of Development (LOD)

In 2008, the American Institute of Architects (AIA) defined the LOD for the first time, but this definition was updated in 2013. LOD definition is that The LOD specifies the minimum spatial, dimensional, quantitative, qualitative, and other data required in a Model Component to support the approved uses related to that LOD (Alshorafa & Ergen, 2019). As shown in Figure 10, the LOD is classified into five levels according

to AIA (Latiffi et al., 2015). However, these definitions are brief and do not show the exact information included in each level (Alshorafa & Ergen, 2019). Nevertheless, it is essential to decide the LOD in the project early phases as it will interfere and directly affect the impact of BIM implementation in all the project phases (Leite et al., 2011). It can be stated that LOD includes the output information for an element or reliability of a model. In contrast, the Lod consists of the component input details (Latiffi et al., 2015).





LEVEL of DEVELOPMENT				
LOD 100	LOD 200	LOD 300	LOD 400	LOD 500
				
Concept (Presentation)	Design Development	Documentation	Construction	Facilities Management
DESCRIPTION: Office Chair Arms, Wheels WIDTH: 700 DEPTH: 450 HEIGHT: 1100 MANUFACTURER: Herman Miller, Inc. MODEL: Mirra LOD: 100	DESCRIPTION: Office Chair Arms, Wheels WIDTH: 700 DEPTH: 450 HEIGHT: 1100 MANUFACTURER: Herman Miller, Inc. MODEL: Mirra LOD: 200	DESCRIPTION: Office Chair Arms, Wheels WIDTH: 700 DEPTH: 450 HEIGHT: 1100 MANUFACTURER: Herman Miller, Inc. MODEL: Mirra LOD: 300	DESCRIPTION: Office Chair Arms, Wheels WIDTH: 685 DEPTH: 430 HEIGHT: 1085 MANUFACTURER: Herman Miller, Inc. MODEL: Mirra LOD: 400	DESCRIPTION: Office Chair Arms, Wheels WIDTH: 685 DEPTH: 430 HEIGHT: 1085 MANUFACTURER: Herman Miller, Inc. MODEL: Mirra PURCHASE DATE: 01/02/2013

Figure 10: Level of development (LOD) levels (Latiffi et al., 2015).

LOD is classified according to the vast amount of information into the level of information (LOI) and level of geometry (LOG). LOI includes non-graphical data that are related to an object or system. LOI is directly proportional to the level of development, which means the higher the LOD, the higher are the non-graphical information included in the model. LOI unique tables can illustrate, deliver, and coordinate the information of an object or model according to the agreed depth and details mentioned in the contract. On the other hand, LOG relates directly to the graphical data in the model. It is used mainly in design phases (Mavreli, 2018).

LOD grades

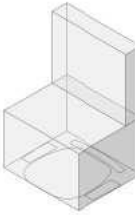
According to BIMForum interpretation, the following Table 2 shows the different grade definitions.

LOD	BIMForum interpretation	Example of a light fixture
LOD 100	"elements are not geometric representations. Examples are information attached to other model elements or symbols showing the existence of a part but not its shape, size, or precise location. Any information derived from LOD 100 elements must be considered approximate".	"Cost/SF attached to the floor slabs."
LOD 200	"At these LOD elements are generic placeholders. They may be recognizable as the components they are, or they may be volumes for space reservation. Any information derived from LOD 200 elements must be considered approximate".	"Light fixture, generic/approximate size/shape/location"
LOD 300	"The quantity, size, shape, location, and orientation of the element as designed can be measured directly from the model without referring to non-modelled information such as notes or dimension call-outs. The project origin is defined, and the element is located accurately concerning the project origin".	"Design specified 2x4 troffer, specific size/shape/location"
LOD 350	"Parts necessary for coordination of the element with nearby or attached elements are modelled. These parts will include such items as supports and connections. The quantity, size, shape, location, and orientation of the element as designed can be measured directly from the model without referring to non-modelled information such as notes or dimension call-outs".	"Actual model, lightolier DPA2G12LS232, specific size/shape/location"
LOD 400	"A LOD 400 element is modelled at sufficient detail and accuracy for fabrication of the represented component. Thus, the quantity, size, shape, location, and orientation of the element as designed can be measured directly from the model without referring to non-modelled information such as notes or dimension call-outs".	"As 350, plus special mounting details, as in a decorative soffit."
LOD 500 (not used)	"Since LOD 500 relates to field verification and is not an indication of progression to a higher level of model element geometry or non-graphic information, this specification does not define or illustrate it".	Non

Table 2: LOD different grades definitions and examples according to BIMForum (Alferieff & Bomba, 2019).

LOD in precast

LOD 100 includes only assumed information about the element dimensions (height, width, and size) with flexible location coordinates in Precast elements. As shown in Figure 11, LOD 200 includes the element information regarding the type of elements structural system and its approximate geometry. LOD 300 includes precise information about the size and location of the structural element with correct orientation and information about the sloping and element cut surface, excluding the elements related to a specific manufacturer. LOD 350 includes information about (e.g., locations of post-tension profiles and strands, chamfers, pouring joints, lifting points and devices, expansion joints, anchor rods and embeds, MEP-related items, and any permanent forming element). LOD 400 includes all the steel reinforcement, including detailed post-tension modelled elements and finishes (Alferieff & Bomba, 2019)(BIMForum, 2019).

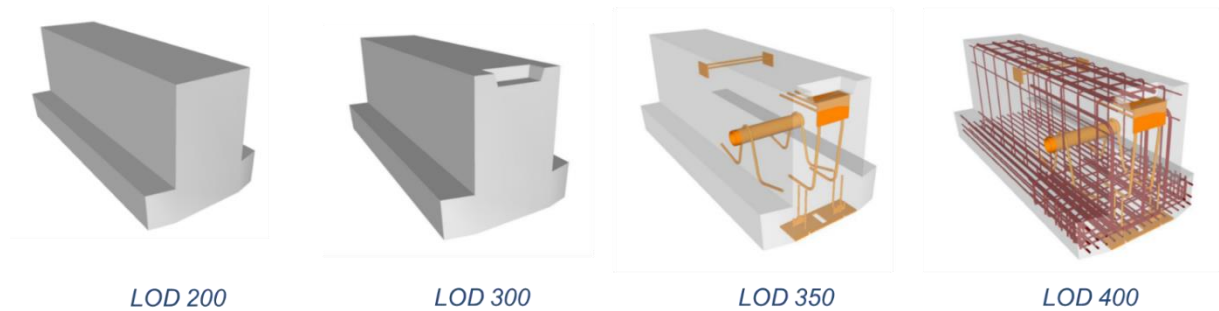

Figure 11: Different LOD of concrete Precast Structural Inverted T, adopted from (Alferieff & Bomba, 2019).

Finally, from the LOD specification, it can be stated that there is no such thing as a BIM model with a specific grade of LOD. Within the model, there will be different elements with different LOD grades according to the stage of delivery and modelling details. With more information and graphical/ non-graphical information, the level of development of the model will increase. According to a specific level, this variation from LOD 100, LOD 200, LOD 300 to LOD 400 or LOD 500 is according to a specific level satisfied for the organization's needs and standards (Sadeghi et al., 2019).

3.5 BIM benefits

BIM advantages vary from one dimension to another. In the 3D coordination dimension, having the ability to visualize a 3D model that is to scale increases the ability of clash detection between different elements. One example is the clash detection of Mechanical, electrical, and plumbing (MEP) piping and a structural steel beam, as shown

in Figure 12 (Azhar et al., 2008). 4D simulation preparation is improved with the ability to link the BIM model to the project schedule. It enables a fast update of the 4D simulation model when the schedule or the structural models are changed as all the input information is accurate, detailed, and up-to-date (Tulke & Hanff, 2007). With built-in cost estimation and quantity takeoff tools in the BIM software(s) (Azhar et al., 2008). This feature increases the capability of accurate automatic quantity takeoffs from the BIM model, easing up the different phases of cost estimation at any time in the project's life (Sabol, 2008).

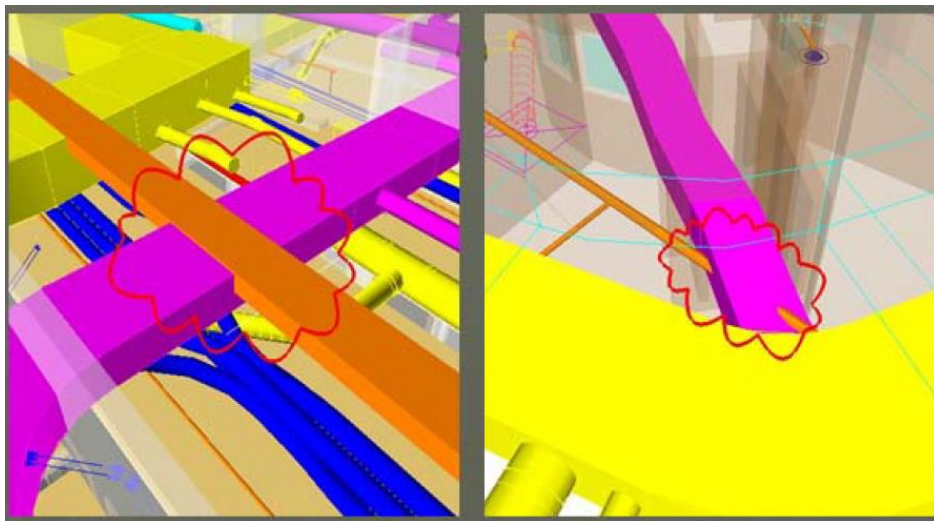

Figure 12: An Illustration of clash detections via Building Information Modeling (Azhar et al., 2008).

BIM provides an isolated model that includes all the data for the subcontractors' suppliers and vendors regarding the procurement process (Masood et al., 2014). Facility managers use BIM tools in the renovation, repair, space planning, restoration, and operation in operation and maintenance processes. It provides them with all the needed information in the model database and facilitates its exchange (Liu, 2010).

Concept design and detailed design are the best phases to integrate construction safety assessments to prevent accidents in the future, as shown from different researches. That is why 8D BIM tools provide a safety and risk assessment of the facility's different design elements to be used in the design process (Kamardeen, 2010). Based on 32 major projects using BIM, Stanford University Center for Integrated Facilities Engineering (CIFE) stated that the BIM indicates benefits of; more than 40% un-budget change elimination. Time used to create cost estimation is reduced by 80%, and 3% accuracy of cost estimation. They also stated that the clash detection feature

saves up to 10% of the contract value, and project duration is reduced by 7% after using BIM tools (Azhar et al., 2008).

BIM benefits can also be classified according to the BIM user, for project owners: meeting all project requirements due to early design assessment, using operation simulation to assess the building performance, low financial risk because of the correct cost estimation, better marketing strategies by using 3D models and walk-through animation (Eastman et al., 2011) and finally having complete information of the building in one location (Ku & Taiebat, 2011).

Furthermore, from the project designer's point of view, BIM tools supply better design, environmental and sustainable performance prediction, fast production for detailed drawings, and early analysis for future failures (Gardezi et al., 2014). Finally, in the construction phase, better customer care, comparing different costs and schedules, improved quality, management, decision-making, enhancing and higher profitability benefit contractors and subcontractors (Hardin & Mccool, 2015).

3.6 BIM challenges

BIM systems face different challenges and risks that vary according to certain conditions such as the country, field of use, and the industry surrounding environment. These challenges lead to difficulties in integrating BIM in the AEC industry (Gardezi et al., 2014). BIM implementation faces risks such as inaccurate data entry causing model errors, missing data due to various program usage, and incorrect BIM implementation and management due to lack of transparent BIM methodology and guidelines (Azhar, 2011). Technological and process are considered two related risk categories that are related to BIM challenges. Lack of BIM guidelines for BIM implementation and interconnectivity between systems used in construction are considered Technological associated risks. Process-related risks are legal risks such as low determination of the ownership of data used and not using copyright laws to protect these data, in addition to contractual risks regarding responsibility for any inaccuracy in the model (Thompson & Miner, 2006).

Ku and Taiebat (2011) stated that BIM integration barriers are; lack of skilled users, slow learning curve, and expensive implementation cost. Furthermore, the

unwillingness of some project parties, interoperability, lack of cooperative work standards, and insufficient legal/ contractual measures are considered to be significant challenges.

In China, BIM challenges are classified according to technical, managerial, environmental, financial, and legal difficulties, as illustrated in Figure 13 (Tan et al., 2019).

Category	Challenges
Technical	<ul style="list-style-type: none"> • BIM technology adaptation difficulties • Insufficient Domestic- oriented BIM tool • model development workload increase
Management	<ul style="list-style-type: none"> • Change unacceptance • Data sharing negative attitude • Incomplete understanding of BIM • Bad cooperation • Lack of a proper BIM-based workflow
Environmental	<ul style="list-style-type: none"> • The external motivation for using BIM is not enough • Lack of BIM implementation researches in china
Financial	<ul style="list-style-type: none"> • Fear of high training cost and durations • High cost of BIM experts and software(s) • Fear of increase in design cost
Legal	<ul style="list-style-type: none"> • Insufficient protection for copy rights • Lack of BIM standards and guidelines for contracts and reliability • No proper insurance regarding the applicability of BIM implementation.

Figure 13: Categories of potential barriers adopted from (Tan et al., 2019).

From the previous findings, despite having such advantages in the BIM system, some barriers and challenges came to the surface when implemented in the AEC/FM industry. Some of these challenges had been solved nowadays, and some other barriers are not. Nevertheless, BIM implementation advantages are far greater than its challenges. With the continuous development of the system and research, the BIM system barriers will decrease eventually into not existing, leaving only the BIM benefits for the industry prosperous.

4. Paperless System

4.1. Definition and history

Previously, blueprints and sketches were used to convey a particular construction plan (Kravchenko, 2020). The primary method of data storage, communication, and exchange of information inside and outside an organization is paper (Mushhad et al., 2009). Replacing the paper system was not the primary goal of any company, but having higher productivity to enhance customer satisfaction is always one of the main goals (Djassemi & Sena 2006). The term paperless system related to construction does not have a specific definition as it is not widely used. One of the few definitions of paperless construction is using electronic software(s) for handling contracts, managing and modifying drawings, viewing submittals and inspection reports (Hackman et al., 2004). On the other hand, the Drawing-less system is described as the system that replaces the traditional paper-based system in transferring documented information between parties with a model-based environment. Paperless drawings refer that paper is not used but replaced with electronic software that illustrates printed paper (Valkoniemi, 2019).

It can be stated that a paperless system is replacing a paper-based traditional system using digital BIM-based models (drawings-less systems). It also includes the use of paperless drawings instead of paper-based drawings. This new definition is based on the fact that BIM is a computable description of the building's physical properties created by digital technology (National BIM Standard Project Committee, 2007). Another reason for this definition is the relation of electronic or computable software with paperless systems. With this relation of paperless system with BIM, it is clear that any digital use of BIM tools on an electronic device for replacing the traditional paper system to achieve or enhance a specific goal can be considered a paperless system, as shown in Figure 14.

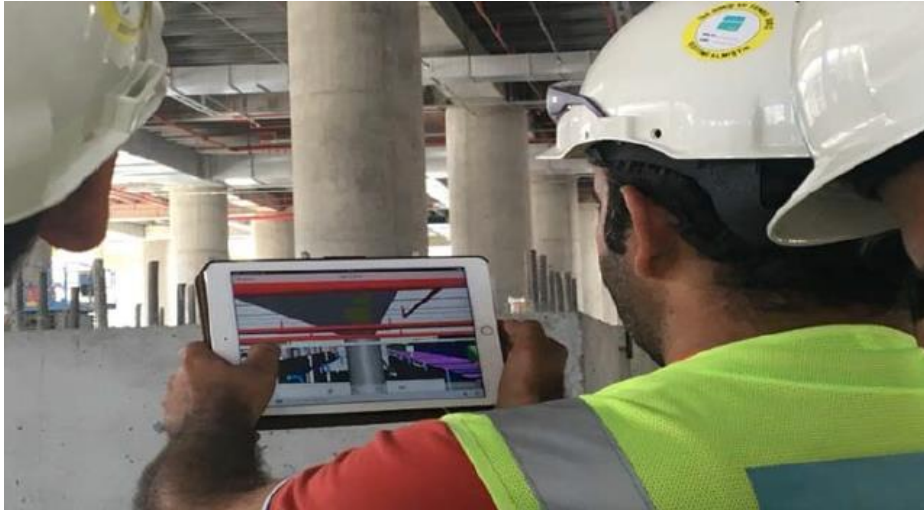

Figure 14: Site team using an electronic device to view a BIM model in the construction site (Koseoglu & Nurtan-Gunes, 2018).

The majority of construction firms depend on manual processes and outdated communication methods instead of using new technologies (Nourbakhsh et al., 2012). BIM is used only as a representation tool in almost 88 % of BIM projects, according to a market survey in 2012 (Koseoglu & Nurtan-Gunes, 2018). Different BIM usages are mainly related to office use on a computer during the project lifecycle. The main goal is to improve the communication process between different project parties through 3D modelling, visualization, simulation, and documentation (Wang et al., 2012). BIM-based Paperless implementation in the construction process is restricted with only prototype systems designed for one specific task in the construction site (Santos et al., 2017).

BIM is used today as a primary tool to create the drawings and the models of a building. The end product generated from the BIM tool used in the construction process is still a 2D drawing (Valkoniemi, 2019). Even though most projects are now modelled in 3D, however, 2D drawings are still widely standard. This use of 2D drawings is due to a wrong understanding that a large amount of information and its accuracy can only be represented using 2D drawings (Kanungo et al., 1995). The same effort made for implementing BIM in the preconstruction phase must be applied to the fabrication and construction phase to reach its full capabilities (Koseoglu & Nurtan-Gunes, 2018).

Currently, using three-dimensional (3D) BIM-based tools has replaced paper-based 2D drawings in information transfer and communication methods. With this new communication method, data is managed more efficiently, which allows fast and easy decision-making processes. From a construction industry point of view, using BIM tools

will improve productivity and ease the cooperation work within the construction process (Park & Kim, 2015).

4.2. Different BIM-based paperless system tools

4.2.1. Quality assurance

Using BIM tools in quality checks during the project's different phases is considered one of the most critical quality management system activities (Park & Kim, 2015). However, to understand the function of the BIM tool in quality checking, it is necessary to know the point of difference between traditional quality management and BIM-based quality management. Quality management is defined as the process that includes all the procedures to ensure that the project satisfies the agreed needs. Quality management contains all the processes that decide the project's quality policy, responsibilities, and objectives. These elements are implemented using quality assurance, quality control, quality planning, and quality improvement. Quality control is defined as the process or activity that monitors the performance to ensure that it meets the agreed quality standards to determine the reasons for any unsatisfying results (Park & Kim, 2015).

On the other hand, BIM-quality control is defined as the process that ensures the project quality requirements are met through an automated or computerized inspection process. All BIM-based quality checks are executed on a platform for confirming the production, design, erection, and other phases of using a BIM model (Seo et al., 2012). BIM-based quality control methods usage increases process efficiency by saving time. Moreover, The client requirements and the construction system standards and regulations are included in the automated quality inspection process. One of the quality inspection processes is rule checking using software(s) such as; Solibri Model Checker, Trimble Connect, and Navisworks (Park & Kim, 2015).

The importance of quality assurance in the precast concrete industry is critical. Any failure in this process might cause a complete system failure. This failure is resulted from dimension errors and incompatibility of the different precast elements on each other or any other part of the structure through the erection process and received from the production process. The construction industry institute stated that the construction defects generate 5% of the total construction cost for rework (Kim et al., 2016).

Dimensional Quality Assurance (DQA) is one of the quality assurance processes that includes checking the precast concrete unit dimensions and positioning before loading. As per the visualization quality assurance, a certified precast concrete expert is authorized to check the precast unit and ensure that it follows the agreed standards and guidelines (Kim et al., 2016).

Some researchers have investigated non-contact sensing methods to monitor the dimensional properties of structural components. One of the most common and prominent methods for detection is the use of 2D cameras, as shown in Figure 15. Its high speed and low cost of operation are the reason for its popularity when it is used to detect dimensional defects (Ordóñez et al., 2008).

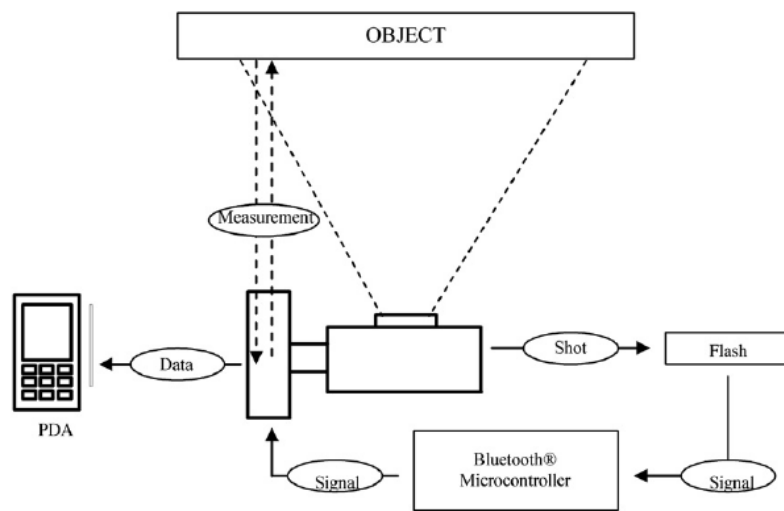

Figure 15: PDA-camera communication system (Ordóñez et al., 2008).

Photogrammetry, which is the system used in 2D camera scanning, is based on adjusting the image coordinates of the camera according to the different coordinates points of the object scanned. Furthermore, it is using some predefined equations to generate a 3D model is, as shown in Figure 16. after extracting these measurements from the object, it is compared with the model version of the element to check for any quality errors (Dai & Lu, 2010). Despite its advantages, some flaws occur in this system. First of all, the external lighting source was needed in the process of data collection. The second flaw is the quality of photos controlled the quality of the error checking system, for example, by having poor lighting conditions. Taking the precast concrete unit as an example, if a shadow was located on the surface of the precast unit, then

extracted data will not be collected smoothly. Moreover, some information might be lost due to the shadowed parts (Kim et al., 2016).

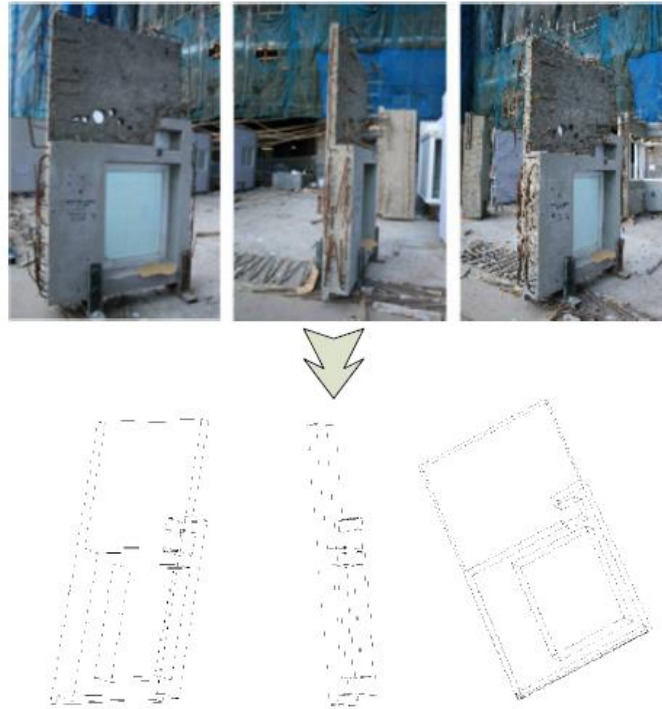

Figure 16: Sample of the generated 3D model generated from the photogrammetry method (Dai & Lu, 2010).

Some findings were generated from a study on developing a fully automated DQA system to check the complete quality checklist on a complex geometry precast concrete element. This technique offers measurement accuracy of 3 millimetres for dimensions and also for the precast element positioning. Moreover, the accuracy of the DQA system depends on how many extracted points are taken from the precast unit. Some other challenges for the system are that the precast concrete element scanning is only for the surface and not covering the sides. However, this problem can be solved with more scanning to the sides added to the current DQA system to generate a complete 3D accurate model for the precast concrete element (Kim et al., 2016).

4.2.2. 3D modelling and 3D annotation

BIM entails the use of three-dimensional intelligent models and significant improvements in project workflow and delivery processes (Hardin & McCool, 2015). Having a precise geometry (geographic information) with sufficient data will support the design,

procurement, and fabrication processes. 3D renderings can be done with no effort by BIM software. The client can preview the whole design (building) before actually constructing the building. Hence, the client could make variations through an early stage and help in reducing the rework and changes. Also, it allows early decision-making concerning the scope of the project. BIM can be viewed as a virtual process that would allow designers to determine conflicts between precast element panels. Using BIM would avoid some problems that can't be noticed in 2D CAD. These problems include geometry or link errors on drawings that can be very expensive to fix during the construction or erection of precast components (Azhar, 2011).

The use of BIM software also reduced the chance of mismatched connections, inappropriate design forms, and geometry conflicts. It allows shop drawings to be made with no need for thorough testing or cross-coordination (Kaner et al., 2008). The BIM model is created to scale in the BIM environment. This advantage improves collision, clashes, and interference detection. By using specific software, the main elements in the BIM model can be automatically checked for clashes or interference. For example, it can be detected if an MEP pipe is passing by structure elements such as a column or beam, as shown in Figure 17 (Azhar, 2011).

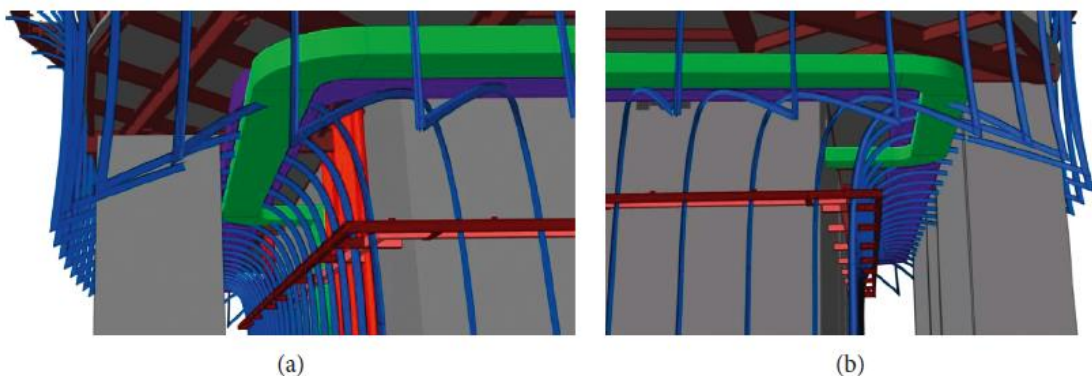

Figure 17: Clash detection between MEP system and secondary beam (Lee et al., 2019)

Thorsten Hertel, the precast fabrication Product Manager at Trimble, introduced the new BIM tools that support the precast concrete fabrication in the Tekla Structures software. 3D annotation tool, which is a new extension for the software, was introduced. This tool allows the information related to the drawing to be represented outside of the 2D drawing format. The 3D model and 2D information are merged, as shown in

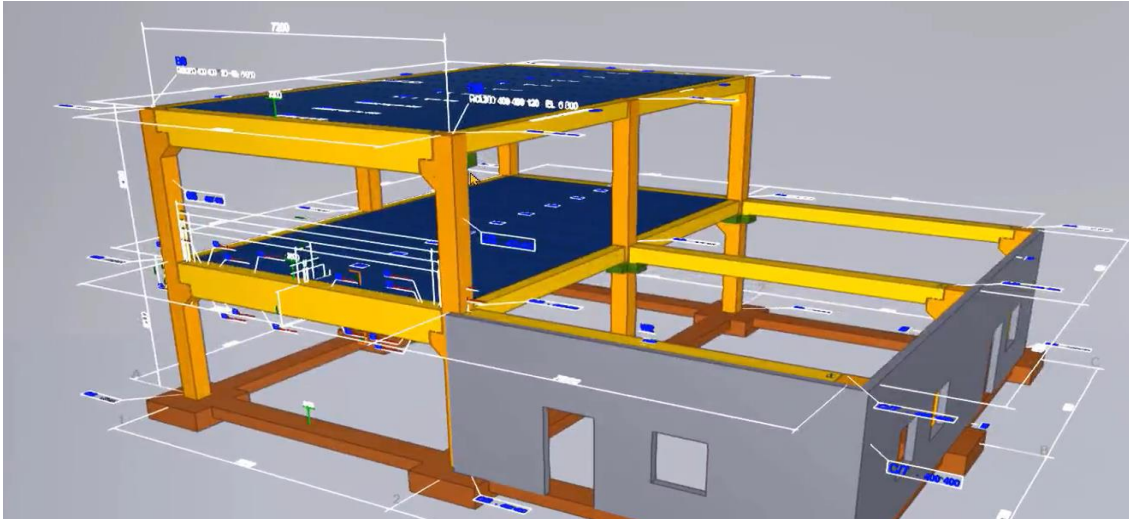

Figure 19: Trimble Connect web view after enabling the 3D annotation tool, previewing the drawing information on the exact location in the model (Thorsten et al., 2021)

4.2.3. Paperless reinforcement production

In the field of fabrication, Drawing-less reinforcement offers better comprehension and helps to avoid miscalculation. It also generates a layout plan with the proper mounting order, prefabricates the reinforcement cage, generates a bending list directly from the model to the bending unit, and decides the status of the rebar as ordered-mounted (Jalali, 2018).

BundesVereinigung der BauSoftwarehäuser (BVBS) is one of the file formats used to transfer information between the 3D model and the production site quickly and efficiently (Maciel & Corrêa, 2016). BVBS file format provides an efficient method for automating the rebar cut and bend process. 3D steel reinforcement (RFT) production can be done using IFC or BVBS file format. Many parameters are defined and generated through the different processes, as shown in Figure 20 (Jalali, 2018).

In the modelling phase, the model follows specific requirements and standards for calculation and analysis. The created Excel file includes parameters such as the production stage and shape code. The last stage of cutting and bending includes bar diameter, material grade, and the total amount of steel. As illustrated in Figure 20, 3D reinforcement production starts with the BIM model exported from the BIM software as BVBS or IFC. The file is transferred to the cutting and bending machine for the RFT production. A PDF document is created automatically from the machine to be evaluated before the product delivery. The project consultant and the contractor either

approve or disapprove the document. After approval, the cut and shaped RFT are transported to the construction site or production yard for assembly (Jalali, 2018).



Figure 20: The required information in every stage and the lifecycle of the automated RFT fabrication from model to site (Jalali, 2018).

4.2.4. 3D coordination and clash detection tools

The digital representation of all the construction model elements using BIM-based software is the first step toward 3D coordination. The BIM model is used by different project stakeholders using different BIM tools. Different specifications such as the British publicity available specification (PAS) states that the user can have access to a specific sub-model of the related scope of work only. A digital data platform is used to store the information and the models. This data platform is called a Common data environment (CDE). CDE is a shared space used to collect, manage, share and evaluate information between different parties. An example of the CDE system is Trimble Connect software.

The use of the CDE ensures the availability of up-to-date data at all times as that the users use it to either retrieve or update and restore data on it (Preidel et al., 2017).

The collaboration of different project parties starts at the early stage of the project until its finalization. The 3D coordination starts after the model compilation to check clashes with different parties. The proper use of the BIM-based 3D coordination has a significant impact on the design error reduction and enhancing the scope of work understanding by comparing a traditional project with a BIM-based project from the perspective of coordination. The 3D coordination model decreased the request for information (RFI) by 37% and the coordination change orders by 32 % (Hergunsel, 2011).

By implementation, the BIM tools in the project from its start the project visualization improves. This improvement in visualization enhances the clash detection of the building's different components. By decreasing the clashes between different elements such as structural elements with MEP elements or other structural elements, as illustrated in Figure 21 or, cost-saving is achieved by decreasing the coordination errors. Clash detection technique can be applied to all elements of the building or project. The clashes are detected either visually or using BIM software (e.g., Solibri) that automatically detect the clashes by generating report and highlighting the clashed objects (Mostafa et al., 2020). The Solibri generated report explains the type of clash, location, and the exceeded tolerance.

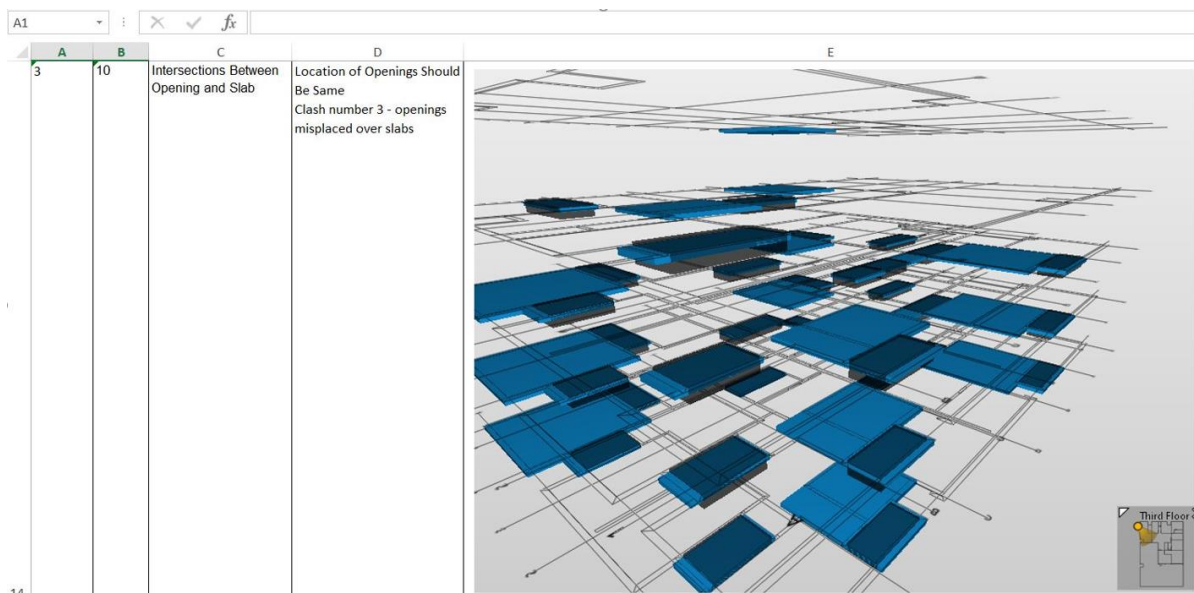

Figure 21: Solibri clash detection report with selecting of the clashed objects (by author)

4.2.5 Augmented reality tool

With the evolving technologies over time, augmented reality (AR) and its usage in construction sites have evolved. Hence, the wide range of information on this topic. This section only explains a simple model of AR implementation in the construction industry, highlighting the different advantages.

AR is used to illustrate the actual and the virtual object by combining digital information and 3D elements on the actual object using an electronic device. This tool allows a better understanding and better visualization of information and objects on-site. One of the AR software(s) is Augmented reality for construction (AR4C) (Ratajczak et al., 2019). One method to use the AR software is to combine the BIM model and location-based system (LBMS). LBMS is a management system that combines construction activities and their location (Kenley & Seppänen, 2006). The aim of combining the BIM model with the LBMS, in this case, is to provide an interactive 3D model and allow the visualization of the construction tasks on site (Ratajczak et al., 2019). Using AR allow the possibility of showing as-built projects and construction process visualization (Grubert et al., 2016).

The construction activities are defined using a work breakdown structure (WBS) code. These codes are added to the different elements in the BIM model, as shown in Figure 22. The inserted codes are connected to the master schedule in or outside the model. Unity software is used to import the generated file. Unity 3D is an AR platform used to create the augmented reality for construction applications. The information generated from Unity 3D software will allow the graphical representation of the construction activities' location and progress. The use of AR4C in the construction site will allow the users to see their assigned task and its location on the model. Moreover, it will enable them to see all the information on the installation process in the AR environment (Ratajczak et al., 2019).

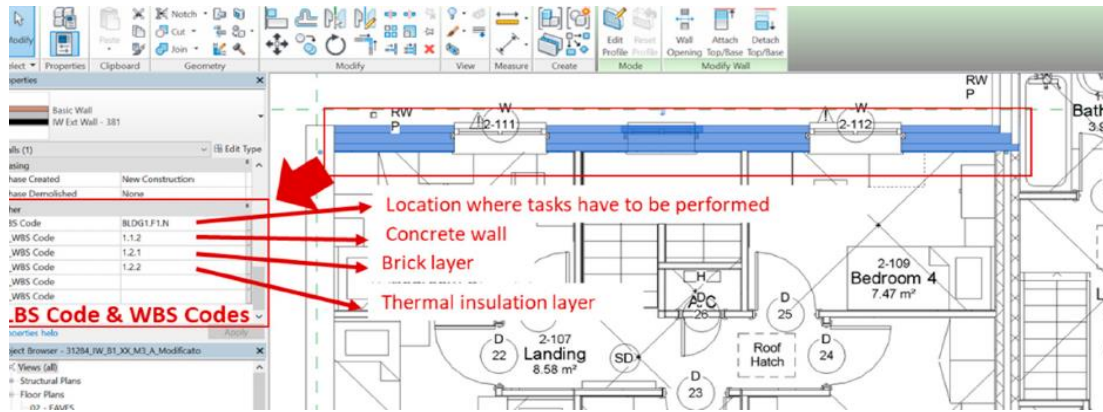

Figure 22: WBS code inside the element property on the modelling software (Ratajczak et al., 2019).

The advantages of using this specific Method of AR in the construction site are many. One of the advantages is the automated monitoring for the construction site progress using the AR tool. The scope of work understanding is increased by allowing the user to see his tasks in reality. Enhancing the visualization process allows the user to walk through the construction site and see different 3D elements. It provided the user with all needed information regarding his scope of work by selecting the desired component or task from the model. Additional layers can be shown separately by using filters to show only the needed element on-site. However, this specific use is still under development due to its complicated errors in aligning the model with the actual environment (Ratajczak et al., 2019).

4.3. Advantages of implementing the BIM-based paperless system with the precast concrete system.

There are many advantages regarding the implementation of the BIM-based paperless system with prefabricated elements, and these advantages are as the following (Mostafa et al., 2020):

- the error generated from insufficient coordination is minimized due to the high similarities between the initial BIM model and the production team's final model;
- The implementation decreased the procurement time and change orders because of the automated method used by the BIM software for generating the procurement data. In this advantage, the procurement errors such as not having an updated quantity or making modifications that may affect the quantities are solved;

- Information exchange efficiency is increased by using the BIM system;
- The fabrication process lifecycle is reduced, and the productivity increased;
- Errors that are generated due to coordination and communication are minimized.

4.4. BIM-based paperless system implementation challenges

From a survey made by Mostafa et al., (2020) the implementation of the BIM technology in the prefabricated industry has challenges, which are:

- Changing the company structure from the traditional system into adopting BIM technology. Since the use of BIM will be implemented through the full lifecycle of the project, a proper implementation must be made. Changing the company structure from this aspect will be a challenging and expensive task;
- BIM software to be used instead of CAD software. This change will require an investment from the company side to implement it by giving proper training and changing hardware systems if necessary;
- Working with BIM tools needs training and a new BIM-adoptive system to work efficiently in the production stage from the contractor's side;
- Legal and collaborative problems make it hard to define the responsibilities while using the BIM system, making it hard to assign liabilities. This disadvantage is that the BIM model will be used instead of the traditional contracts and delivery methods. This challenge can be solved by the support of the government for the system. The system will enhance if the government issued specific rules and standards for using the paperless system. Implementing the BIM system in governmental projects will ease the process and encourage the private sector to start investing;
- One last challenge is defining the needed information that every team member has access to in the master model according to his scope of work.

In conclusion, the BIM-based paperless system has many fields of usage in the fabrication process. Quality Assurance, 3D coordination, 3D annotation, coordination tools, and reinforcement production are parts of many other uses. Since it is a new system, it has many advantages for the precast concrete industry regarding increasing efficiency or enhancing its quality. The system faces some challenges, but it can be solved with proper implementation techniques and governmental support.

5. Case Studies

5.1 Introduction

Through the conceptual work and the deep literature review work presented earlier in chapters 2, 3 and 4, the research questions 1, 2, and 3 were answered. The different BIM-based paperless system improvements and their implementation challenges were discussed in chapter 3 and 4. The integration of BIM-based tools in the fabrication process was covered as well in the same chapters. Finally, some improvement indications were discussed regarding cost, quality, and productivity. However, the last question is related strongly to the precast concrete industry elements complexity. This question-answer can only be obtained from either a field case study or a survey distributed to different precast concrete players.

The paperless implementation on a full-scale project is still new to the construction industry. It was discussed in chapter 2 some similarities regarding the precast technology and the traditional system. These two systems are both construction systems with many similarities in design, construction methods, and management. Moreover, the same BIM-based paperless tools used in precast construction are used in the cast in situ system.

The case study chapter will be divided into two sections. The first section will be discussing a drawing-less system implementation on a full-scale cast in situ project. Randselva bridge case study will discuss the implementation techniques, challenges, and different advantages. An analysis of this project will provide the author with an excellent data set to prove or contradict the findings of this study. The second section of this case study chapter is a survey directed to different experts in the construction field to confirm or deny the results of this implementation and answer the study's last question. The survey questions will discuss the usability and the readiness of the precast concrete industry and the construction industry to adopt this new system.

5.2 Randselva bridge case study

This case study's data is collected through the cooperation and data exchange of Sweco company after a meeting with Oystein Ulvestad. Oystein is a BIM Developer at Sweco; he graduated from the Norwegian University of Science and Technology

(NTNU) in 2000 with a Master of Science in structural engineering. Oystein joined SWECO in 2013; he is one of the team members responsible for the Randselva bridge in Norway. Videos, pictures, qualitative data, and two articles were provided from Oystein's side to extract and analyse the critical information that was already discussed in our meeting. After the data collection process and the meetings, an explanation of the project is presented, and findings of the paperless and drawing-less system implementation, advantages, and challenges are discussed (Bd&E Magazine, 2020).

5.2.1 Project description

Randselva bridge is the world's longest bridge built without drawings, and it is located 50 km northwest of Oslo city. Its length is 634 meters, with 200 meters as the main span. Six piers are distributed on the bridge length with different heights ranges from 5 meters to 42 meters, as shown in Figure 23. The bridge deck's highest point is 55 meters from ground level. It has The largest hammerhead measures 13.3 meters in height and 14.5 meters in width (Bd&E Magazine, 2020). The project includes more than 200 tendons, over 200,000 rebars and, more than 200 concrete pouring phases. The total project quantities are 22,000 meters of prestressing, 19334.8 m³ of concrete, 17988.2 m² of formwork, and 2885.6 tons of reinforcement.

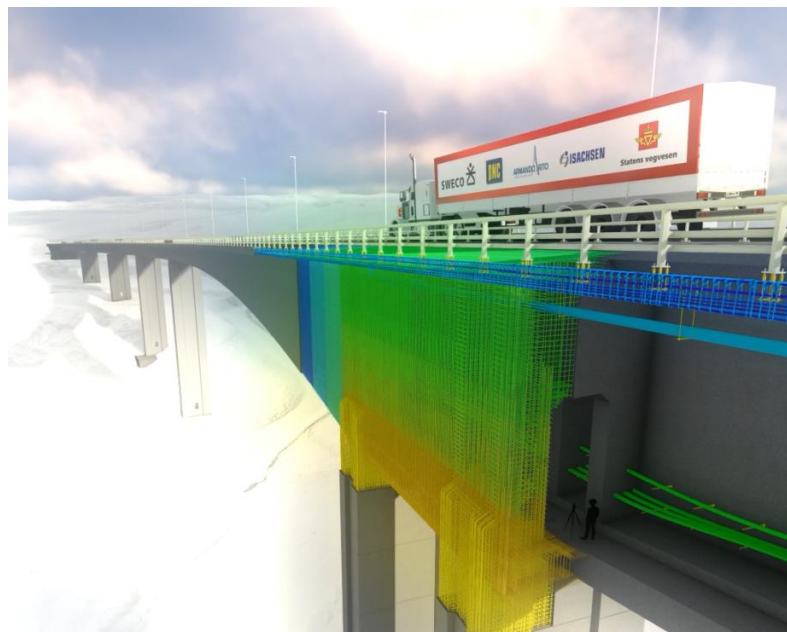

Figure 23: Randselva bridge model (Copyrights for Sweco company with the permission of the author's use only).

PNC Norway is the leading contractor company responsible for the construction work in the project. The ground contractor is Isachsen and Sweco, with Armando Rito's arete design team. Finally, the client is the Norwegian public roads administration (NPRA). NPRA started adopting model-based projects in 2016. It helped the industry make the workflow of this adaptation as easy as possible. Because of this initiative, Norway is now one of the leading countries in drawing-less projects, followed by Finland. NPRA started this BIM-based project adoption by using the BIM models to generate the project drawings. They have noticed a significant drop in change orders as a result of this method of development. Better clash management and a better understanding of the scope of work are the primary reasons for a substantial reduction in change orders in BIM ventures (Bd&E Magazine, 2020).

5.2.2 Drawing-less system implementation process

Design and modelling phase.

Sweco provided three essential factors for the drawing-less system implementation to succeed. The first factor is that all the building elements need a standardized attribute set. Secondly, the modelling must include all the building elements. Finally, there must be no significant clashes in the design. In the early stages of the Randselva project, the BIM workflows (e.g., file format, BIM software, user-defined attributes, and how quality control (QC) process to be executed) were defined.

Knowing the BIM model different users and their different usage of the BIM-model is the main success factor of the BIM adoption process. The usage of the BIM model is starting from the parametric design stage until the construction and operation stage. As illustrated in Figure 24, each player uses different forms of information through different software according to his scope of work. The BIM model in the project was distributed in many fields of usage, including construction, multi-disciplinary management, documentation of the actual structure (As-built), third party management, project operation, and bridge maintenance.

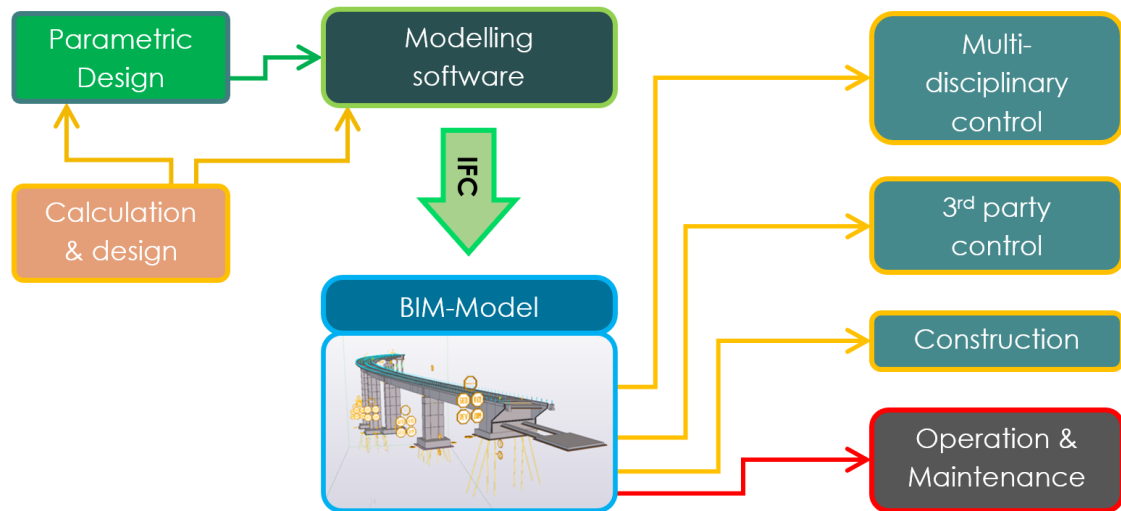

Figure 24: BIM workflow (Copyrights for Sweco company with the permission of the author's use only).

The bridge design was created by the cooperation of four design teams in four countries (Finland, Denmark, Poland, and Norway). The bridge modelling was created using the Tekla Structures software combined with Grasshopper and Rhino for parametric design. The teams were able to work together using a cloud-based model from their local offices. The use of Solibri software in conjunction with BIM Collaboration Format Data (BCF-files) was the primary tool for the third party and the multi-discipline management.

60% of Randselva bridge structure modelling is based on the parametric design. Automated view generation and 3D visualization of the bridge structure are other factors included in the modelling criteria. Parametric design acts as a parametric script (set of rules) inserted into a computer to create a digital model. Parametric design connects the data and information of structural components and any other element related to this component (Park, 2011). There are many advantages of using parametric design in modelling instead of traditional modelling techniques.

Contrary to the traditional drawing-based work system, the parametric-based design saves months of rework. For example, adopting the new road lines if the road centerline is changed can be done in days using the parametric design. However, making the same adaptation by revising the road alignments can take up to months in the traditional system. When the distance between lines changes in the script, the model reconfigures every element and component according to the new changes instantly. This concept can be used in reinforcement or post-tensioning adjustment and modelling, as illustrated in Figure 25. The parametric script used for RFT and geometry of

the structural pier at axis 6 of the bridge is shown below. On the right side of the below figure is how the model looks with different components related to one another. It is concluded that the parametric design decreases human error. This human error is created because of carelessness and defects. Moreover, Many of the parametric scripts can be reused in future projects.

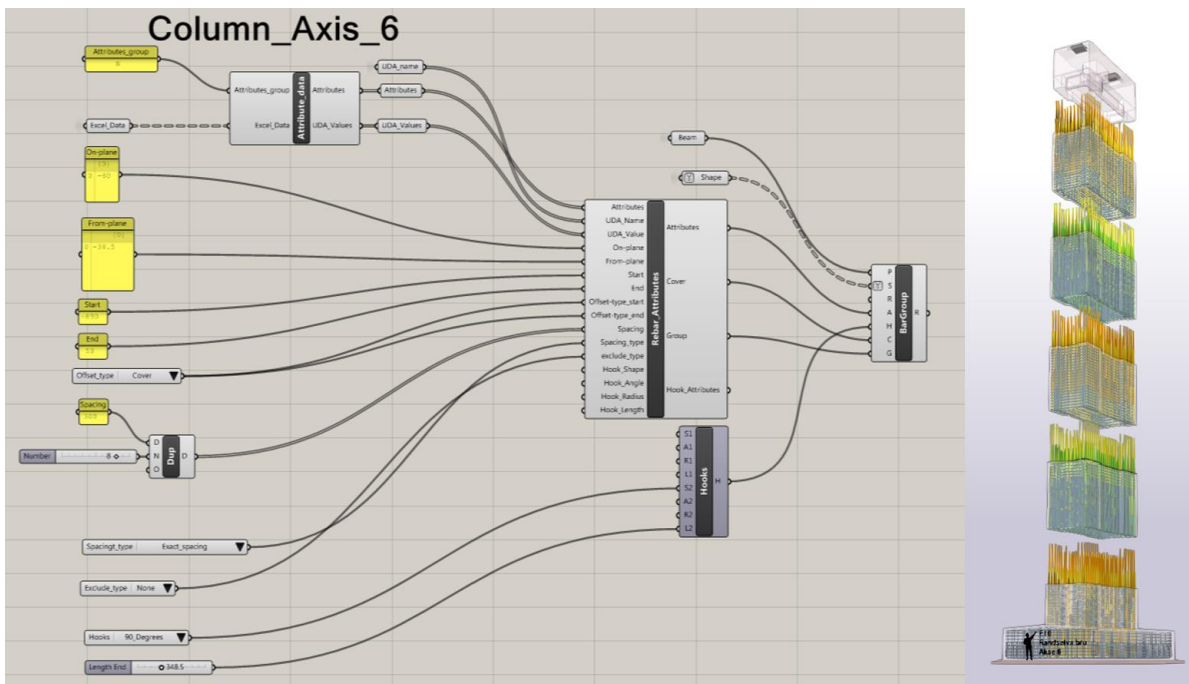

Figure 25: Parametric design script and illustration of the relationship between components (Copyrights for Sweco company with the permission of the author's use only).

By adding more beneficial object attributes to the BIM model, the quality of the model increases. Attributes are the object information. Some attributes are predefined in the BIM software related to the object. Other attributes are inserted depending on the information needed to be shown on the object. An example of the object attribute is the user-defined attributes (UDA) used in the E16 element of the Randselva project, as shown in Table 3.

UDA-name	Info example	Description
01 Object name	Foundation	Name of object.
02 Description	Crane foundation	More thorough description of object if needed
03 Object code	C2	Object code (In Norway: vegvesen.no)
04 Process	84410000	Main process (In Norway: handbook R762)
05 LOD	350	Level of detailing
06 Status	3 rd party control	Object status
07 Revision	01	Object revision
08 Revisions date	2019.05.14	Date of revision
09 Placement priority	1	If clashing, what object should be prioritized
10 Material	C45	Material quality
11 Dimension	Tube Ø120	Dimension (only if not clearly given by the object)
12 Con. sequence	3C01-01	Construction sequence / pour phase of object
13 Free attribut_01	K01-005 -	Drawing name and number
14 Free attribut_02	https://a360.co/DSFJDF	Link to drawing
...

Table 3: User-defined attributes used in the E16 Randselva project (Copyrights for Sweco company with the permission of the author's use only).

These attributes can be accessed by viewing the object on Solibri viewer and selecting the object shown as illustrated in Figure 26. These attributes can be used in the different project lifecycle, and every user can extract the needed information that will serve his scope of work. Because of the revised requirement through the project's long lifetime, some attribute changes will be needed. Changing or adding an attribute can be easily executed in the BIM model in later stages.

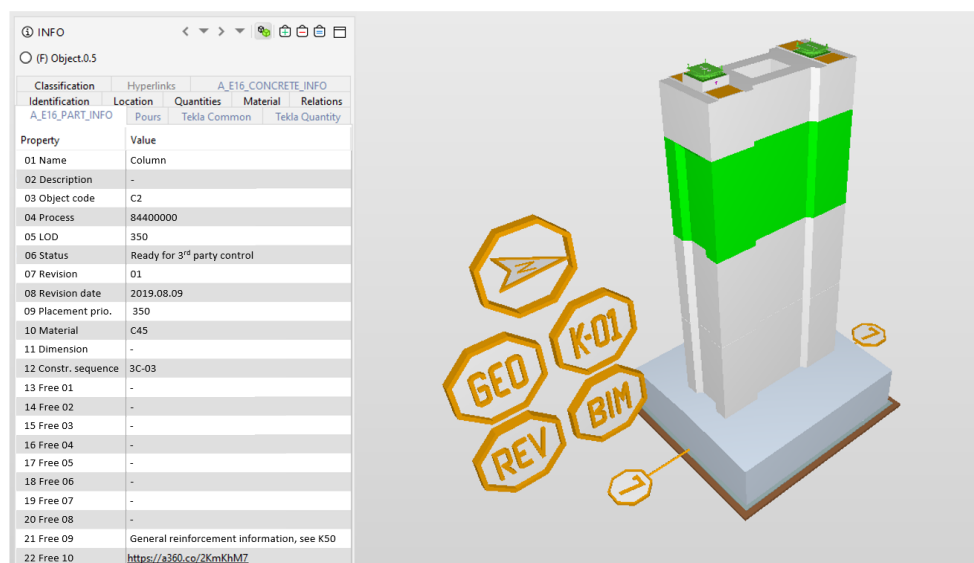

Figure 26: The custom-made curtain "A_E16_PART_INFO" shows the UDAs added for a column part of the Randselva bridge (Copyrights for Sweco company with the permission of the author's use only).

Another factor that is very important in modelling such a project is the level of detail. It contributes to a better understanding of the work scope and better clash detection management. A certain level of detail must be met in the modelling. The only problem is that the high amount of details inserted in the BIM model will cause some technical troubles in the model viewing process, such as lagging. In the Randselva bridge, the post-tensioning geometry has high complexity. This complexity made the modelling of the different post-tension components challenging. For better clash detection, the tendons' outer shape and anchorages were only used in modelling. The company delivering the post-tensioning product took care of the inner geometry of the anchorage system and the steel strands.

As shown in Figure 27, In the Randsvela bridge, more than 200 tendons are modelled using a specific level of detail. However, modelling the circular geometry of the anchorage and tendons would cause a problem by increasing the model size. This problem was avoided by replacing the circular geometry with 8, 12, or 24 sided profiles due to its high similarity to the circular shape.

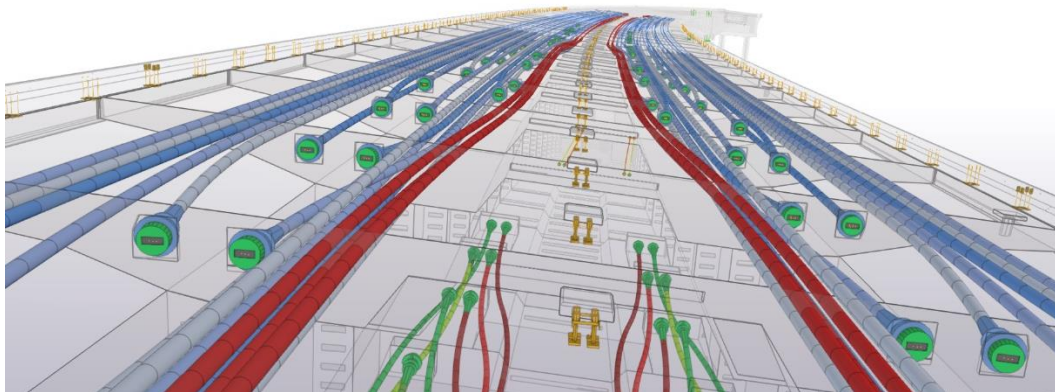

Figure 27: Randselva bridge model includes over 200 tendons (Copyrights for Sweco company with the permission of the author's use only).

Figure 28 shows a BIM model of a joint mixed with BIM models of superstructure and abutment, which is another example of the degree of detail conducted at Randselva bridge. Having this level of detail helps and eases up understanding the scope of work for subcontractors.

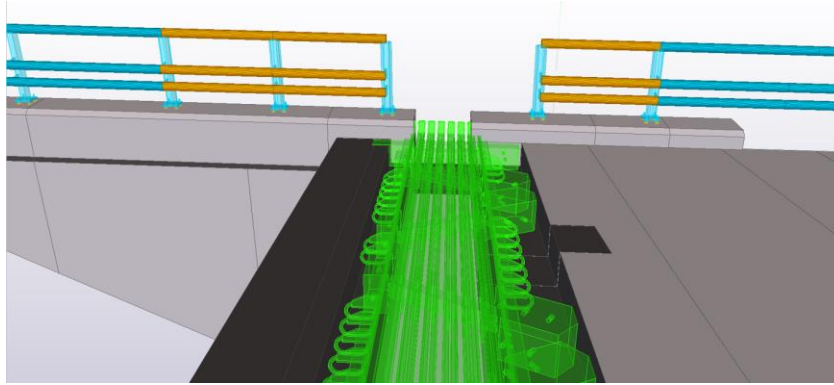

Figure 28: Expansion joint BIM-model combined with BIM-model of superstructure and abutment.
(Copyrights for Sweco company with the permission of the author's use only)

For a better clash control over the reinforcement installation and its intersections with other primary elements, all the structural reinforcements of the project are modelled, as shown in Figure 29. However, not all modelled reinforcement steel rebars do not clash. The clashes that can be easily fixed on the construction site are allowed. The reinforcement order can be done automatically by extracting the needed bar bending schedules without manual-made schedules.

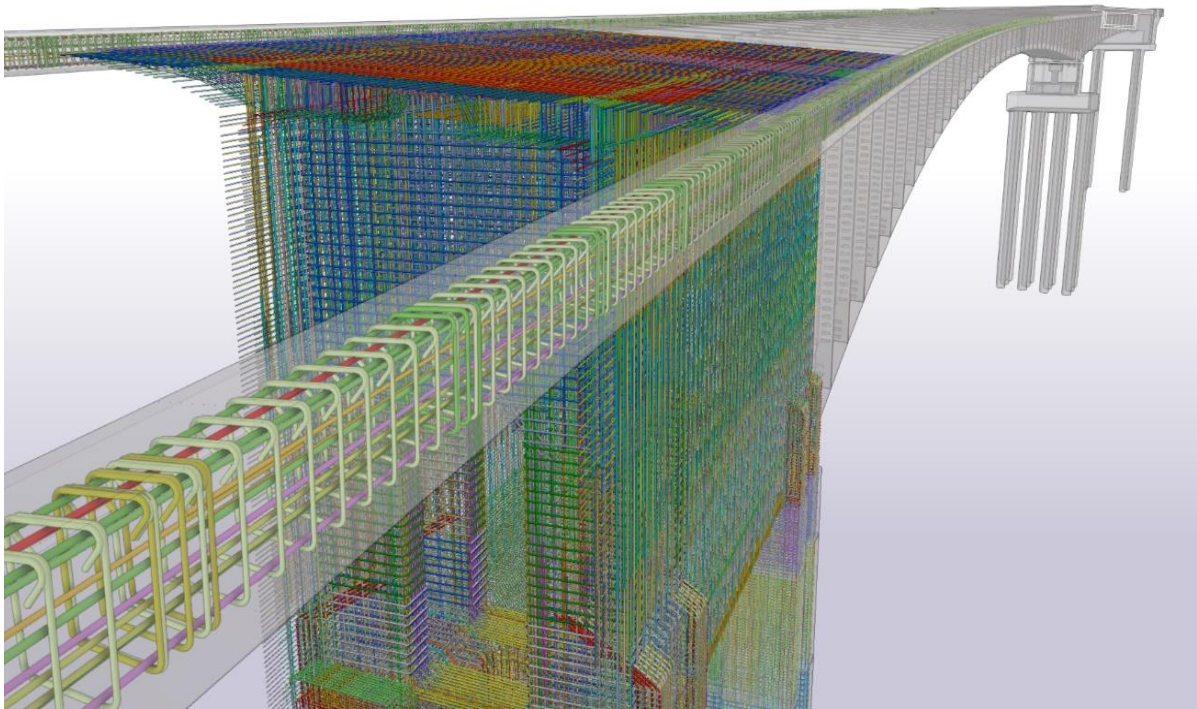

Figure 29: Randselva bridge has more than 200 000 rebars (Copyrights for Sweco company with the permission of the author's use only).

Construction phase

For operating a BIM-based project, the use of specific construction BIM tools was a must. BIM stations were prepared at the construction site, as shown in Figure 31. The use of these BIM stations was essential because of their many advantages and different usages. BIM stations are used as the BIM tools installed for model information delivery to the production team in the construction site. Tablets are used as the primary mobile BIM device that allows flexible and fast access to the data instantly on site.

Trimble Sitevision shown in Figure 30, is an augmented reality device that brings the concept to life, allowing visualization and exploration of complex data with unmatched precision. The Sitevision tool is used for visualization of solutions, process simulation, and information access. Having these advantages, the Sitevision increased the constructability knowledge with a considerable enhancement for the visualization concept formulation for the construction team.



Figure 31: BIM- Station at the construction site (Copyrights for Sweco company with the permission of the author's use only).



Figure 30: Trimble SiteVision Tool used in Randselva bridge (Copyrights for Sweco company with the permission of the author's use only).

The BIM model usage in the construction phase exceeded any other stage of the project lifecycle. However, the software used in construction has the capacity for more development and improvement. There are four main activities in the construction stage where the BIM model is implemented. The four Activities include Backfilling and Earthwork (a), surveying and scaffolding construction (B), third-party product placement and production (C), and finally, RFT installation (D), as shown in Figure 32.

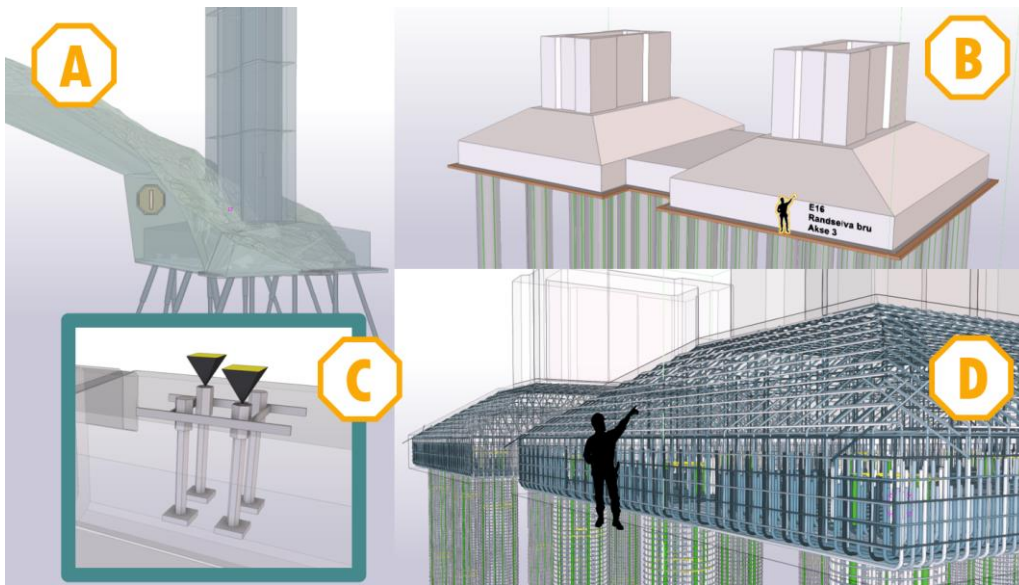

Figure 32: The four primary purposes for using BIM models at the construction site (Copyrights for Sweco company with the permission of the author's use only).

The reinforcement workflow was improved significantly by using a 3D reinforcement system in the BIM model. The rebar process delivery and production were operated based only on the IFC file. The contractor avoided the traditional delays of delivering the bending list to the supplier due to the automatic generation of these tables directly from the model, as shown in Figure 33. The contractor's future requests were already defined in the model. A smooth delivery system without delays was created due to solving the collision problems in an early phase of the project.

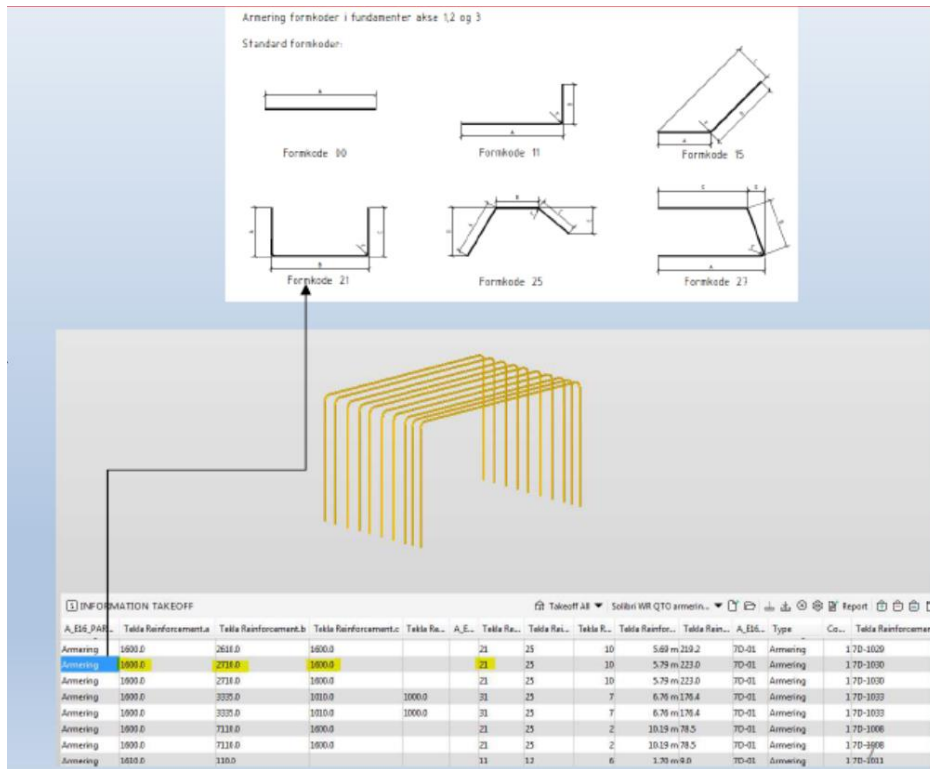

Figure 33: Bar binding list created automatically from Solibri model (Copyrights for Sweco company with the permission of the author's use only).

As illustrated in Figure 34, the generated details of the rebar from the model included all the needed information, e.g., number, type, and location.

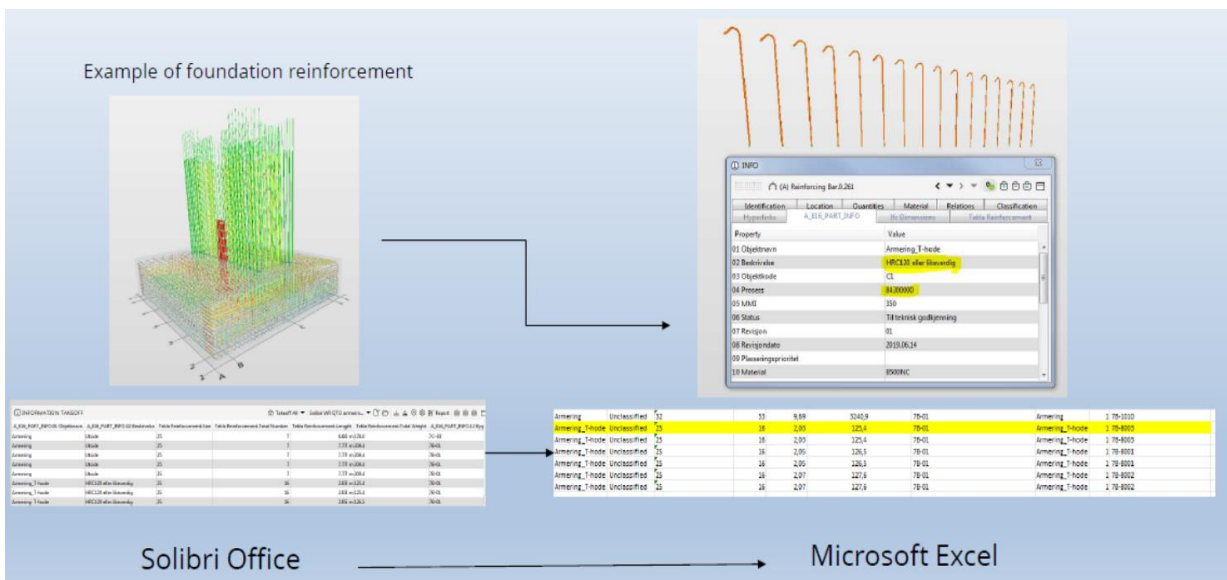

Figure 34: Properties of the rebar data, including the needed information (Copyrights for Sweco company with the permission of the author's use only).

After the fabrication, all the details are printed using the label system shown in figure 35 to be attached to the related rebar.



lhht. NS 3576-3											
	Kunde	PNC NORGE AS		Prosjekt	E16 RANDESLVABRU / EGGEMOE		Tegningnr.	FFB3_D3_S301_A DEL	Prosjektnr.	24355	
	Tegningnr.	FFB3_D3_S301	Boyetliste	SB301A	Posnr.	1008	Posnr.	1008	Diam.	Ø16	Antall
Diam.	Ø16	Antall	25	656.		5025		Kapplengde / Lasting	Burt / Levering	vekt / Side / Prod.enhet	
Dor:	50	Vekt	199					5030	1 av 1	199	
Kval.	B500NC				Prod.:	08-01-21	Cargo:	28-02-21	P	1	18925 / 1
Bunt	1 av 1				Lista Bend R20		656.				

Figure 35: Rebar label system (Copyrights for Sweco company with the permission of the author's use only).

Each site team is provided with tablets to access the BIM model and extract the needed data. The data exchange format used in this project was the IFC format, as it was the only format that followed the Norwegian guidelines and specifications. Also, using the IFC format allows accessing the files through various software(s).

5.2.3 Results and findings

Parametric design advantages

Creating the project using parametric design as explained improved the design modifications adaptability by decreasing the manual interfering factor. Moreover, this usage reduced the consumed time spent on working on similar tasks. Using this design method in modelling created a model with an easier editing process and high flexibility towards new design adaptation and usage. All the tendons, more than 50% of RFT, and more than 50% of concrete forms in the Randselva bridge were created using this method.

Communication advantages

Easier cross-border communication because of the use of a BIM-based model instead of drawings. Each country has its drawing format; however, the BIM model interface and looks are the same. This model similarity improved cross-border communication. Accessibility to information was improved due to a cloud-based model. Increase in communication speed due to the on-time access to the updated design that is updated

automatically. Data updates, model modifications, comments are all presented in the same environment with the ability of the user to check the related data to his or her scope. These data can be related to the foundation details, rebar fixing details, or scaffolding setting up details.

Scope of work understanding improvements

The traditional method of using 2D drawing provided the user with a limited amount of primary data and details such as dimensions and levels with no ability to explain the sequence of work. However, the BIM model allows the user to gain access to any data required for his work scope with the advantage of describing the sequence of work. These advantages improved the scope of work understanding in different phases of planning and construction. As illustrated in Figure 36, the steps are visualized by colours according to their order and then commented to give more information to the construction team.

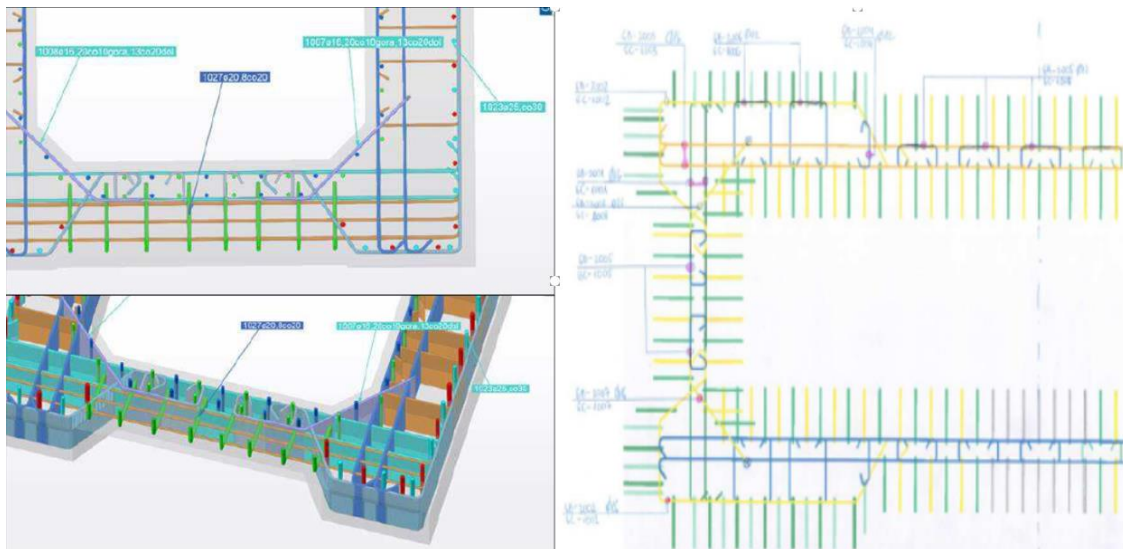

Figure 36: Steps marked in colours in a printed drawing and the BIM model (Copyrights for Sweco company with the permission of the author's use only).

Another advantage of using the BIM model is the construction sequence attribute. These attributes are defined in the BIM model, when viewed on Solibri software, illustrated the relationship between each element and its related cast unit. The contractor used this tool to enhance their work sequence for the concrete works, post-tensioning, and reinforcement, as shown in Figure 37. The logistics work was positively impacted for better preparation and execution in the construction site.

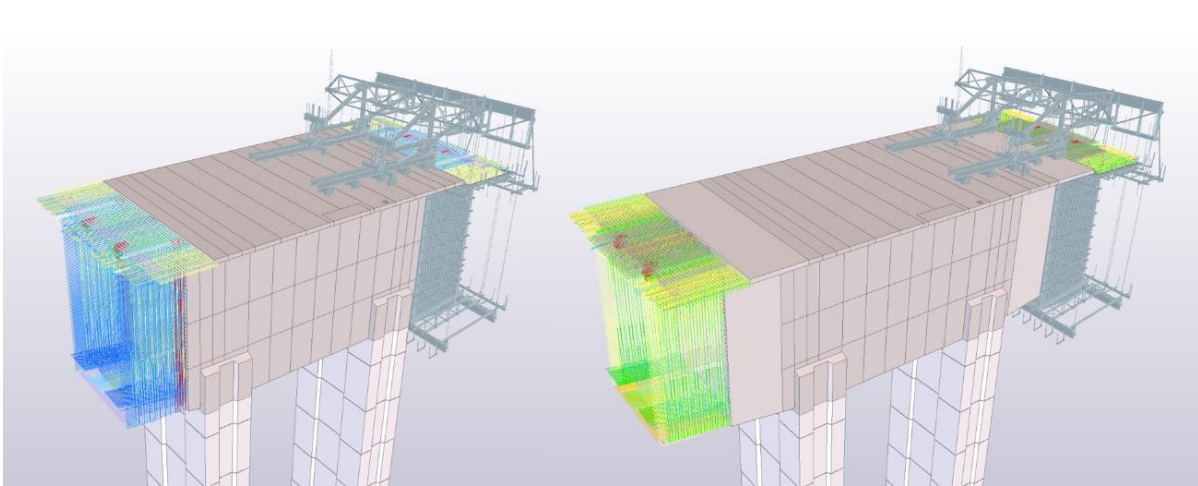

Figure 37: Using UDAs (user-defined attributes) shows different construction sequences (Axis 3: segments 01 and segments 02 phases) (Copyrights for Sweco company with the permission of the author's use only).

Clash detection improvement

The clashes and defects were detected more effortlessly than on drawings with the BIM model. Detecting the early conflicts decreased the number of surprising problems on site. Doing that decreases the cost and time consumption used compared to a paper-based project. As shown in Figure 38, on the right side of the picture, there is a detailed drawing of the steel reinforcement on top of a concrete pile and intersecting with the upper foundation bottom reinforcement. The exact details of this reinforcement are represented from the BIM model perspective on the left side of the picture. Instantly, it can be noticed that the 3D representation enhanced the scope of work understanding from the first look at this view. Furthermore, it improved the clash detection process by offering more details and data about this specific work area.

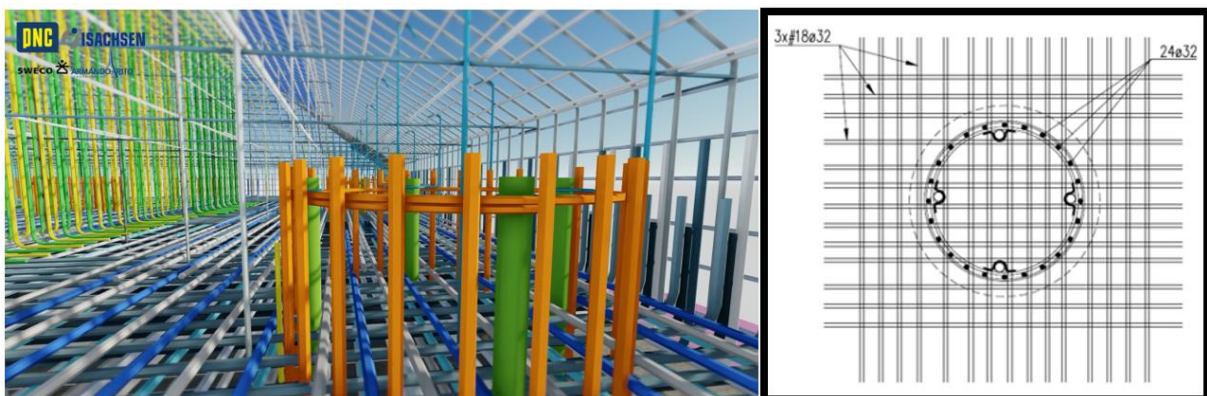

Figure 38: The drawing detail (right) and the 3D-BIM model perspective (left) (Copyrights for Sweco company with the permission of the author's use only).

Moreover, as shown in Figure 39, expensive mockups can be replaced with digital mockups that are faster and cheaper to produce. Using tablets in manufacturing the actual design on-site has improved the Quality and precision of the concrete element.

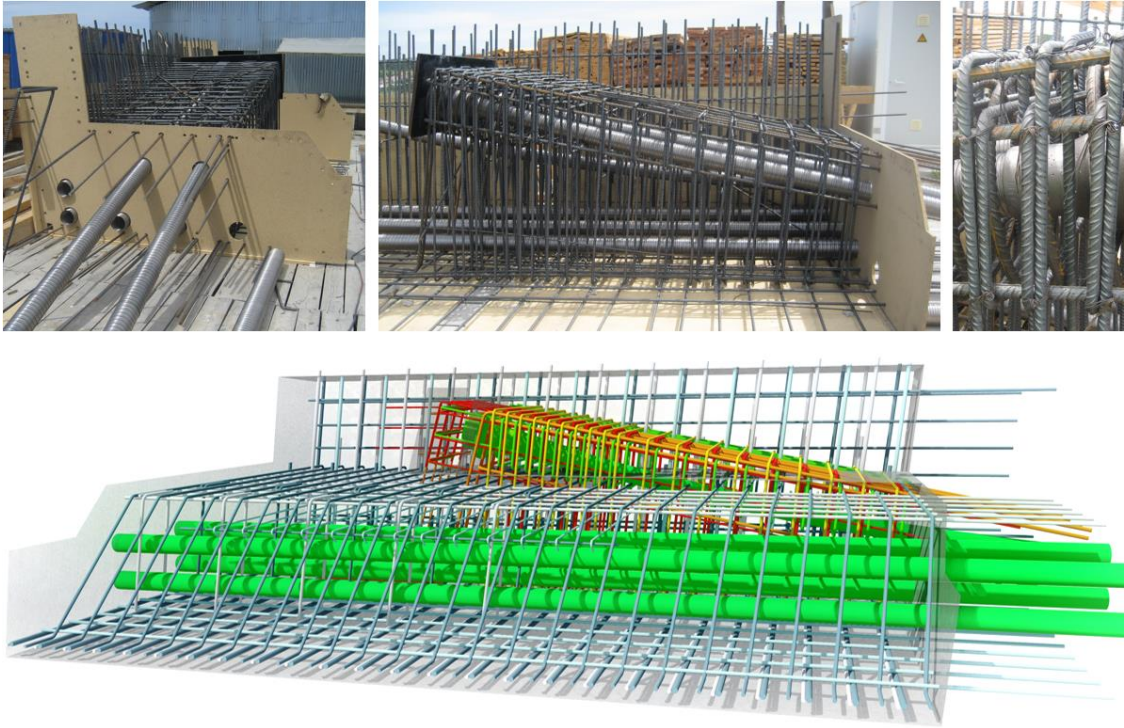

Figure 39: Digital mock-ups have replaced traditional 1:1 construction-site mock-ups (Copyrights for Sweco company with the permission of the author's use only).

Augmented reality advantages

BIM-based models provided augmented reality advantages for the site team. Figure 40 and Figure 41 shows that the augmented reality tool was used in the steel and pipes installation process. The positioning of, for example, piles and scaffolding were controlled by using the augmented reality tool. It also provided a good design visualization tool at the site. The design and details were illustrated on the tablet with millimetres of error without the help of a surveyor. An early problem and error detection mechanism was provided by this tool to the project.

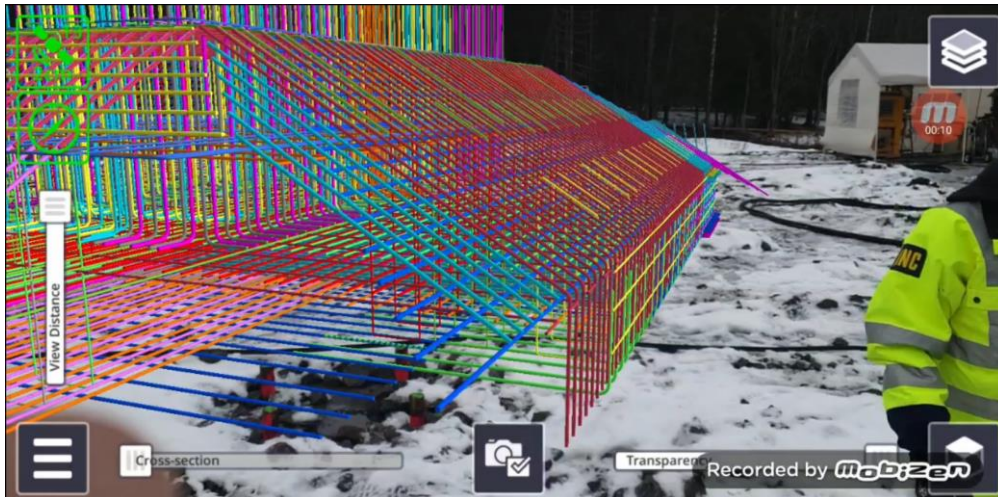

Figure 40: Augmented reality steel reinforcement illustrated in its location at the site (Copyrights for Sweco company with the permission of the author's use only).



Figure 41: Augmented reality for the bridge location illustrated in its correct coordinates at the site (Copyrights for Sweco company with the permission of the author's use only).

The augmented reality tool was operated using a wireless tool (SiteVision) connected to a mobile device. The modelled elements needed were combined with the background environment using the mobile device's camera to illustrate a full-scale visualization of the component in reality, as shown in Figure 42.



Figure 42: Site team member using SiteVision to visualize the column alignment on-site (Copyrights for Sweco company with the permission of the author's use only).

Procurement advantages

The BIM model includes all the project elements with precise and up-to-date information related to each component, including the information related to quantities. This advantage created an automated tool for quantity take-off (QTO) for any element (e.g., the bar bending list of the RFT and the number of post-tension anchorages). By following this automated method, the use of the traditional manual method of QTO is eliminated, and the procurement process was improved.

Maintenance advantages

BIM-based models will be fundamental in the field of operation and maintenance by combining the models with the inspection data. This combination will enhance the maintenance planning structure with the owners. Also, it will improve the flaws detection process by monitoring and finding the flaws from the models.

Future advantages

In the field of using robotic technology in manufacturing, the use of BIM models is essential. Automated technology will only be possible if the drawings are eliminated and replaced with BIM-based models.

Drawing-less implementation challenges

With innovative technologies, new challenges will appear. Quality control old methods are outdated, and finding creative approaches to run this task is still under experimentation. There is difficulty showing the objects removed from the model and ensuring that the input information is well inserted (Lisa, 2019). Another challenge is that the BIM model includes much information. It requires high-quality software with high-quality filtering options to extract the needed data from it. IFC formats might be a future challenge because it is not clear how long they will be used. This uncertainty for the permanent use of IFC files raises concern about the model's usability in the future.

Including UDA information to an element in a BIM model makes informing the user about updated or added objects easy. Notifying the user regarding deleted items, on the other hand, is more complicated since there is no longer an element to which the UDA information can be attached. It is challenging to present tables of information in a BIM model. Traditionally, this has been done by adding links to documents. A reinforcement design applicable to several similar construction elements such as piers can be presented in a drawing and easily managed. Nevertheless, all reinforcement for all components must be included in a BIM model, making modelling and management more difficult.

5.2.4 Complex precast element example

Oystein Ulvestad, the BIM developer at Sweco, illustrated the implementation of the drawing-less system on an example for a complex precast unit. This precast concrete unit is a part of a small project in New Zealand. The corner precast foundation for the precast structure is illustrated in Figure 43. The precast element was overly complex to understand its geometry and execute it from the traditional 2D drawings, as shown in Figure 44.



Figure 43: The complex corner foundation (precast concrete unit) in the construction site after casting (Copyrights for Sweco company with the permission of the author's use only).

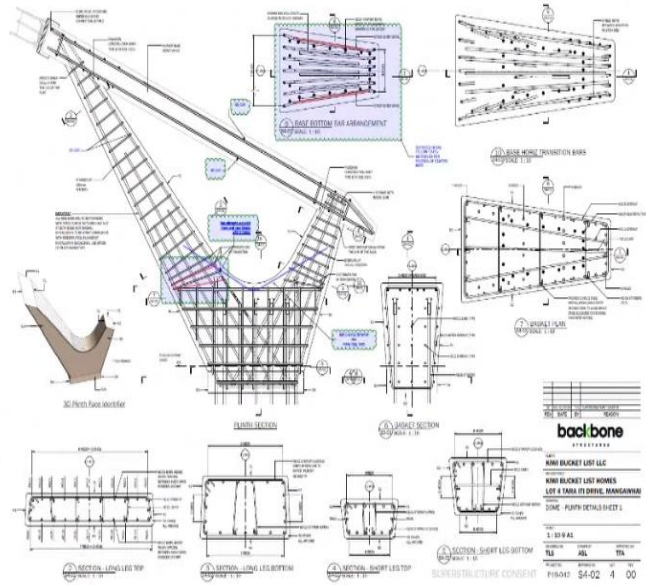

Figure 44: 2D drawings of the same precast unit illustrating the high complexity of the design and shapes (Copyrights for Sweco company with the permission of the author's use only).

The complexity of this precast concrete element was developed from its complicated reinforcement shapes and intersections. A 3D model of the precast concrete part was created, as shown in Figure 45. The model geometry was implemented from REVIT software into Tekla Structures software. Solibri software was used in the visualization and model handling processes.

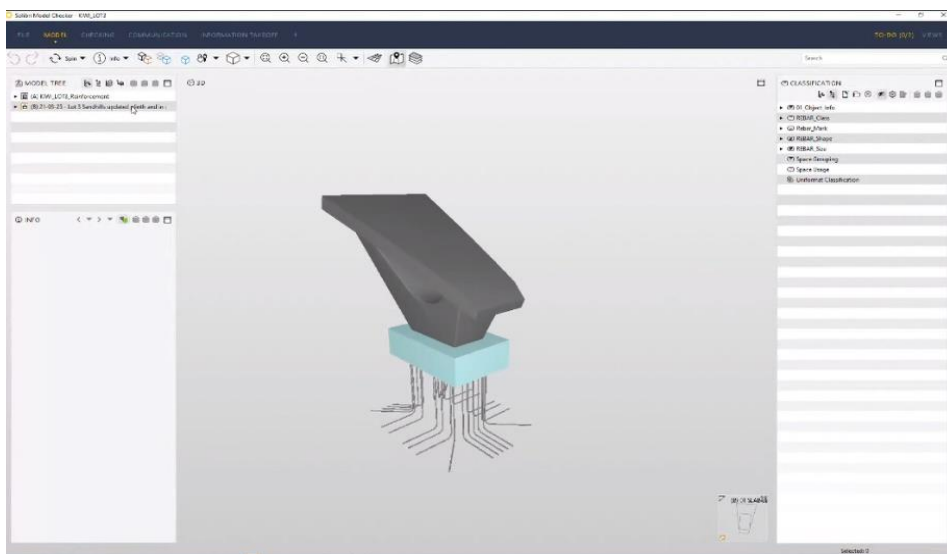

Figure 45: The precast concrete model viewed on Solibri, implemented from Tekla Structures (Copyrights for Sweco company with the permission of the author's use only).

Results and findings

- Model clashes that were hard to detect from the 2D Drawings were quickly solved and detected in the BIM model, as shown in Figure 46.
- The different shapes and all reinforcement defined in the BIM model allowed an automated extracting for the bar bending schedule from the model directly.
- The scope of work understanding increased by showing the reinforcement fabrication order in sequence from the Solibri model, as shown in Figure 47 and Figure 48.
- Adding UDAs increased the amount of information provided. It was easy for every user to check the related data to his scope and use it efficiently by having this variety of data (e.g., Centre to centre distance, the material used, and QTYS).

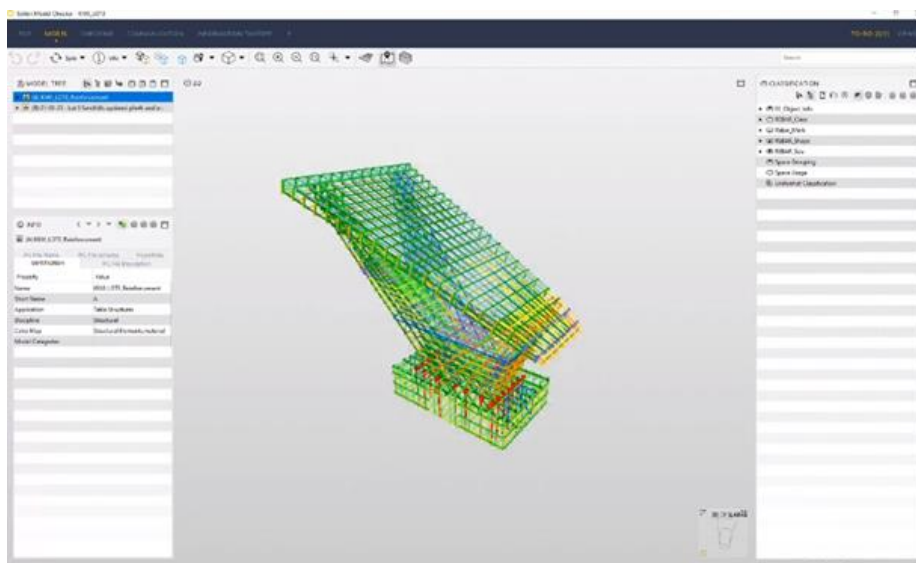

Figure 46: Clash-free reinforcement illustration on the Solibri model (Copyrights for Sweco company with the permission of the author's use only).

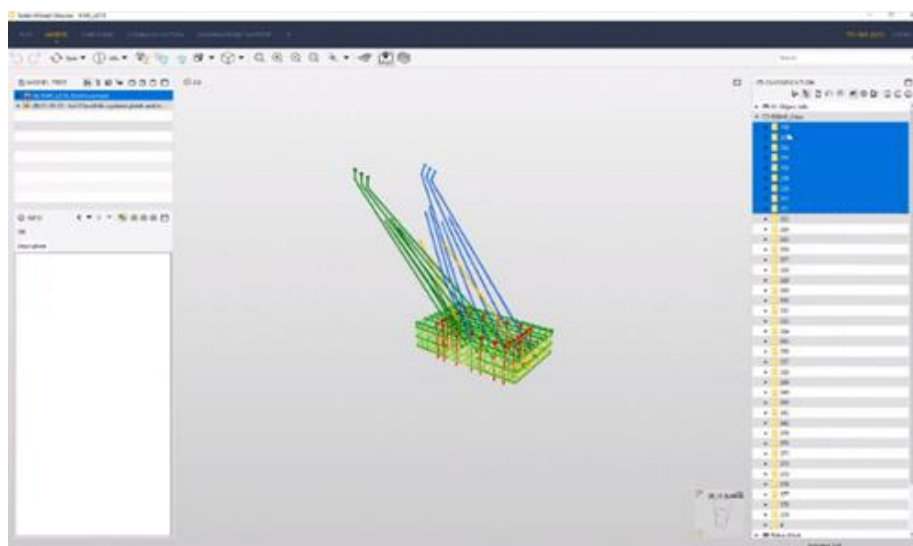

Figure 47: showing the first stages of reinforcement assembly by selecting specific elements to show from the order list on the right side (Copyrights for Sweco company with the permission of the author's use only).

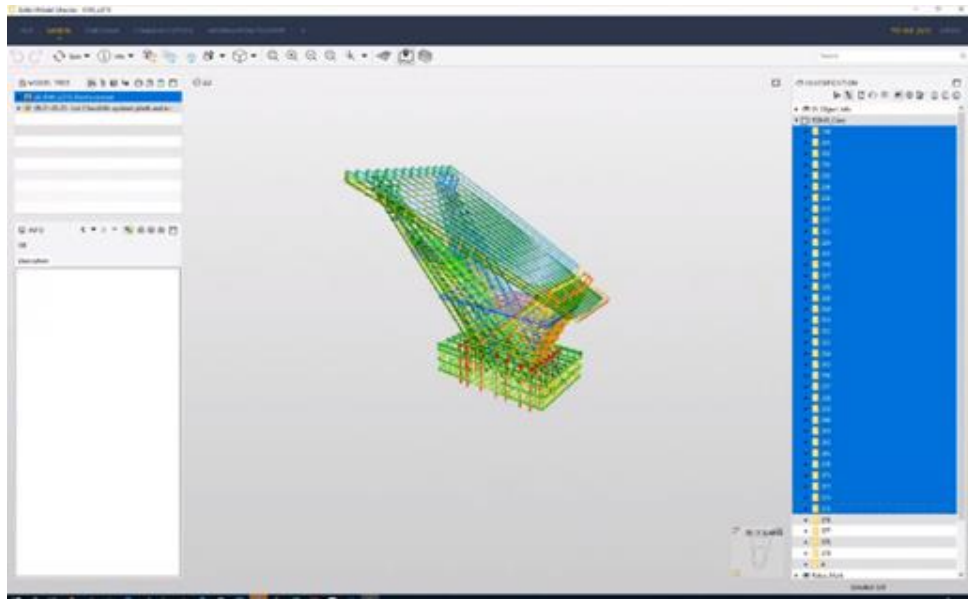

Figure 48: showing the following stages of reinforcement assembly by selecting more elements to show according to its order from the right side (Copyrights for Sweco company with the permission of the author's use only).

The design and production process of this precast concrete element was greatly enhanced by having the 3D model. The 3D model allowed a better understanding of the work scope and faster implementation at the site. As shown in Figure 49, this unit's steel cage was produced in 2 working days regarding its complexity even though it was never done before. From the previous findings, it can be concluded that the production efficiency was increased along with the Quality of the product. With this improvement, it is concluded that the cost of such an element would have been much higher if it was executed using the traditional 2D method.

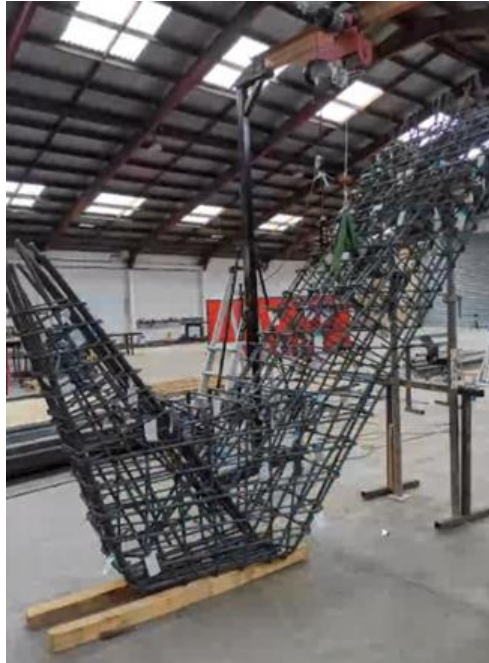

Figure 49: Corner precast concrete unit steel cage (Copyrights for Sweco company with the permission of the author's use only).

5.2.5 Discussion

Through the Randselva bridge design phase, 95% of all the project information is transferred through the 3D BIM model. The project efficiency increased massively by using the parametric design. The BIM use also included Monitoring the model's level of detail and level of development (Model maturity index) at various stages of the construction process from concept and configuration to final as-built objects explained for procurement and implementation.

Considering the future use of the BIM model, The model was used in monitoring and tracking workforce hours' development, efficiency, and productivity with a project control system based on BIM model quantification. Data collection database was provided for future bidding phases, possible claim issuance, final projection of workforce costs and project delay effect on material rental costs delivery, and as-built schedule.

The project team highlighted that this project is only a drawing-less project, but it is vital to keep developing to go paperless for the upcoming projects. Doing this development into paperless projects will require the construction contractor to use the model only in the construction stage, which was never done in the construction industry. The

design team emphasized that going paperless is their primary goal, which they are working on for their future projects.

5.2.6 Conclusion

In conclusion, BIM use in the construction stage played many roles. The BIM management software is used to extract the most up-to-date QTOs, enhance communication for managing technical problems, and share information workflow among all parties concerned. The model enhanced the cooperation between the design team to monitor model revisions and report on the current state.

In order to connect different teams from different countries, Tekla model sharing solutions were used. Furthermore, the internal design cooperation was made using IFC combined with BCF format. In terms of document management, creating and updating BIM models (Delivery confirmation, material orders, and production details assigned to 3D objects) was greatly improved. Moreover, one of the most significant added values was the automation of the material orders with a fully integrated process for the reinforcement supply. Another advantage for procurement is that all the data foundation for supplier product internal design was stored in the BIM model. Furthermore, the augmented reality tool improved the scope of work understanding and the surveying process efficiency.

In the end, from the similarities of the precast concrete and the cast in situ systems, by having in common that they are both construction systems. It can be concluded that the approach to implementing such a system is similar, by having that the master thesis first question was answered. The second research question was covered by highlighting the process of integrating the drawing-less system in the construction phase. Moreover, by understanding the different improvements on cost, productivity and quality, the third question was answered. However, because of the complexity of the last question and the need for an actual case study being implemented at the production factory, it was only possible to briefly illustrate the different effects of this implementation on a complex precast element. This small example concluded that using a BIM model instead of 2D drawings in the design and fabrication stage improved quality, productivity, and cost for complex elements.

5.2.7 Statement of recognition and acknowledgement

I want to express my gratitude to Sweco company and PNC company for cooperating with me in this research. Also, I want to especially thank Oystein Ulvestad (BIM Developer in SWECO) and Wiktor Rybus (BIM/VDC Coordinator in PNC) for their outstanding effort to contribute to this research by providing me with all the needed data and feedback used in this case study.

5.3 Survey

The initial approach to validate or contradict this research was to collect qualitative data regarding the subject through interviews with experts in the field. But the interview approach faced some obstacles. The limitations occurred because of the COVID-19 situation and the unavailability of the candidates to attend the interviews. To solve this problem and to collect the needed data, selective questions were designed in a survey form and distributed to experts in the field. The survey aim was to replace the qualitative interviews by collecting the needed data from a target group of experts in the construction industry.

The survey covered the different effects of paperless BIM-based implementation on the construction field in general and specifically on the fabrication process. The following sections cover the survey's design approach, survey content, survey reliability, survey validity, survey analysis approach, survey limitations, survey results and analysis, and finally, a conclusion.

5.3.1 Survey design

The author carried out deep literature research and a case study to understand the different effects of the BIM-based paperless system on the construction process. This research provided the author with an overview of the paperless system position in the construction industry. The survey questions were designed to measure the responses through different methods. The first method of analysis followed the ordinal independent Likert-type and Likert-scale methods.

The Likert scale is based on the analysis of collection-set questions with different responses scaled by five answers from strongly agree (1) to strongly disagree (5). On

the other hand, the Likert-type elements are designed as separate questions that follow some Likert scale concepts by having the same response classification. However, the analysis of Likert-type questions is based on a single question analysis only (Boone & Boone, 2012).

The author developed the questions answers based on this theory using the 5 points Likert scale. However, the author added a zero weighted response to remove the answer weight if the answer was (I don't know) from the participant point of view. Answering with (I don't know) means that the participant doesn't have information or knowledge about the question asked, which means that his response will not be reliable in the calculation. The different questions were assigned a weight from 1 to 5 and zero, as shown in the three tables below.

Weight	Answer
1	No improvement
2	Low improvement
3	Average improvement
4	Above-average improvement
5	High improvement
0	I don't know

Table 4: The weight corresponding to every answer according to the improvement related questions.

Weight	Answer
1	Not related
2	Low relation
3	Average relation
4	Above-average relation
5	Extremely related
0	I don't know

Table 5: The weight corresponding to every answer according to the relation related questions

Weight	Answer
1	Not used at all
2	Barely used
3	Average usage
4	Above-average usage
5	Extremely used
0	I don't know

Table 6: The weight corresponding to every answer according to the usability related questions

Another type of question used is the open answers question. The aim of these questions is to provide qualitative answers regarding additional information on the topic based on the participant's experience in the field. Finally, the survey includes multiple-choice and short answer questions.

The author developed the survey design through various workshops with a team from Trimble company. Sakari Lahti, the author's third supervisor, Eeva Pilke, Thorsten Hertel are the team members. The workshops aimed to validate the questionnaire to reflect the research content and to follow Trimble guidelines. Google form platform was used as the survey interface. A link generated from the form was distributed through more than 500 Direct emails to experts in the field, LinkedIn, and Trimble general discussion forum.

5.3.2 Survey content

The survey questions were designed to provide answers based on the participants' experiences to the main research questions. The questions in the questionnaire were designed to fit different fields of the construction industry, not only the precast construction field. This generic classification distinguishes the various effects of the paperless BIM-based system on the whole industry and enables the author to compare the results of this implementation on other construction sectors to the implementation results in the precast industry.

A set of twenty-two questions were classified into three sections as the following:

- The first section discussed the implementation effect of paperless systems on different aspects of the construction industry and the fabrication phase. The reasons for not using the paperless system in the fabrication process are also covered in the first section;
- Section two covered The usability of the paperless system and the readiness of the industry for its implementation;
- Finally, section three included the precipitance's personal information, including Age group, years of experiences, country of residence, company size, and roles in construction. The construction-related field related to every precipitant was answered before the first section to connect it with the following answers.

5.3.3 Survey validity

Validity refers to how well the information gathered corresponds to the subject of the study (Taherdoost, 2016). to ensure high validity for the questionnaire was made by using experts feedback from Trimble team. The team consists of Sakari Lahti, who is the author, third supervisor and the Product Manager of precast design and detailing in Trimble. The second member is Eeva Pilke, a User Experience Specialist in charge of designing surveys in Trimble company. Finally, the third member is Thorsten Hertel, a Product Manager of precast and rebar in Trimble. The team examined the survey content to check if the questions are covering the whole research content for the BIM-based paperless implementation effect on the precast fabrication process.

The survey content was discussed through three rounds. The first round included a presentation for the proposed questions made by the author to the team. The team made many modifications to fit the questionnaire content within the research topic and to follow Trimble guidelines. The second round included the author modifying the questions according to the team feedback and analysis for the first draft. The third and final validation round included a detailed examination for the final draft of the questionnaire. After reviewing, the team validated the survey to be published after ensuring that it covers the research content and following Trimble guidelines.

5.3.4 Survey reliability

The degree to which a measurement of behaviour produces a consistent and reliable result is referred to as reliability (Taherdoost, 2016). The reliability was calculated using the SPSS software reliability test. The reliability of the survey was carried out on 46 responses that were analyzed using Cronbach's alpha coefficient. And the selected questions for the reliability test were 34 ordinal questions in the survey, excluding the open and short answers questions.

Cronbach's alpha coefficient rule is that it ranges from 0 to 1. The closer the score is to 1, the more reliable is the survey results. Suppose Cronbach's alpha coefficient is more than 0.9; in that case, it means that the consistency of the survey is excellent. More than 0.8 result indicates that the reliability is good, and less than 0,5 indicates poor reliability (Gliem & Gliem, 2003). The reliability score was 0.877, which means a good degree of consistency in the survey, as shown in Table 7 below.

Reliability Statistics		
Cronbach's Alpha	Cronbach's Alpha Based on Standardized Items	N of Items
0.877	0.869	34

Table 7: Cronbach's Alpha calculation extracted from SPSS software

5.3.5 Survey limitations

As discussed before, the survey was distributed only to participants with high experience in the construction field. The answers from those experienced individuals increased the validity of the questionnaire. The survey was sent to over 500 members in the industry, focusing on Finland specifically and other countries in general. However, only 50 responses with a 10% response rate were collected within the author's designed schedule, as any additional delay would affect the study completion. This limited number of answers affected the quality of results negatively. It does not cover the whole picture as it was supposed. Furthermore, calculating the population was a very challenging task. The challenge was generated because of the different countries related to the survey participants. Therefore the author focus was based on the quality of the data collected instead of its quantity. Having this collection of information will

also provide the research with some bases of how the market stands within the BIM-based paperless implementation in the construction field.

5.3.6 Analysis approach

the survey analysis was conducted using Power BI software, Excel, SPSS software, and Google form auto-generated analysis figures. One part of the analysis is based on ranking the different effects of BIM-based paperless implementation in the construction field, specifically in the fabrication process. Since that, the answers related to this topic was designed using the Likert scale and Likert-type methods. According to the responses, the relative importance index (RII) is used to rank the results. The range of RII is ranged from 0 to 1. The higher the RII, the higher is the rank of the selected element. RII is calculated using the following equation (Gündüz et al., 2013):

$$RII = \sum W \div (A \times N)$$

Where,

- RII = relative importance index
- W= weighting related to each factor by respondents (e.g., $5n_1 + 4n_2$, where n_1 and n_2 are the frequency of selecting this factor)
- A= highest weight = 5
- N= total number of responses,

in the end, the results are arranged according to their rank in a table using excel. Another analysis technique is using Power BI software to combine different logics to produce a new outcome. By doing that, the answers are classified according to different aspects such as countries, years of experience, the field of construction, and many other factors. Finally, the auto-generated Google form figures provided a general overview of the whole topic.

5.3.7 Survey results, analysis and findings

Participants background results and analysis

The survey's first question was related to the field of construction that is related to the participants. The three main areas were precast concrete (38.8%), steel industry (10.2%) and cast in situ (10.2%). The remaining 40 % were distributed as participants

working in all fields as designers or general contractors and other related industries with the classification as shown in Figure 50.

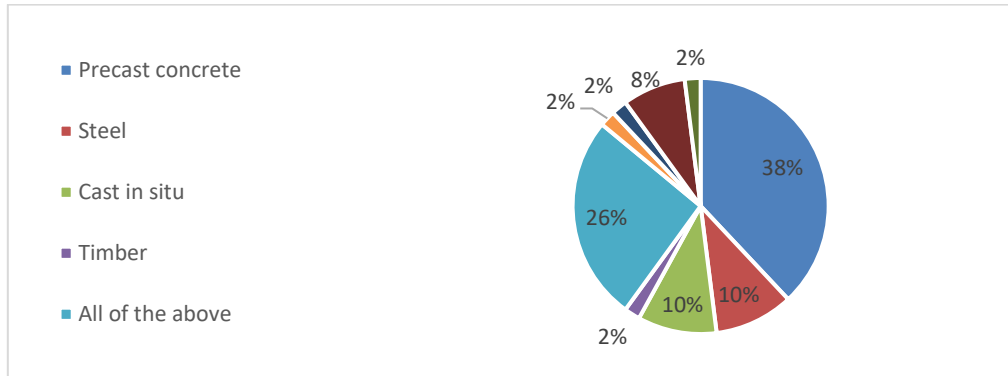

Figure 50: Pie chart showing the different fields of construction related to the participants

A detailed rank was given to the field of construction related to the participants, as shown in Table 8. From the table, it's clear that the participants working in the precast field have the highest rank in the survey. Following them are participants working in Cast in situ, precast, steel and Timber fields. Operating in more than one field is related to the roles in the industry associated with those participants. General contractor, Modeling engineer and some other roles are related to more than one field of construction.

Construction Field	Count	Percentage	Rank
Precast concrete	19	38%	1
All of the above	13	26%	2
Steel	5	10%	3
Cast in situ	5	10%	4
General contractor	4	8%	5
Timber	1	2%	6
Bridges	1	2%	7
Construction service and project development	1	2%	8
Procurement	1	2%	9
Total	50		

Table 8: Detailed rank given to the field of construction related to the participants.

One-third of the participants are working in different roles than the roles provided in the survey. Some of these roles are CEOs, cost control engineers, project directors, owners, BIM detailers, and digital construction engineers. Some of the other roles that participated in this survey are BIM managers, Structural engineers, construction managers, developer engineers, and modelling engineers, as shown in Figure 51.

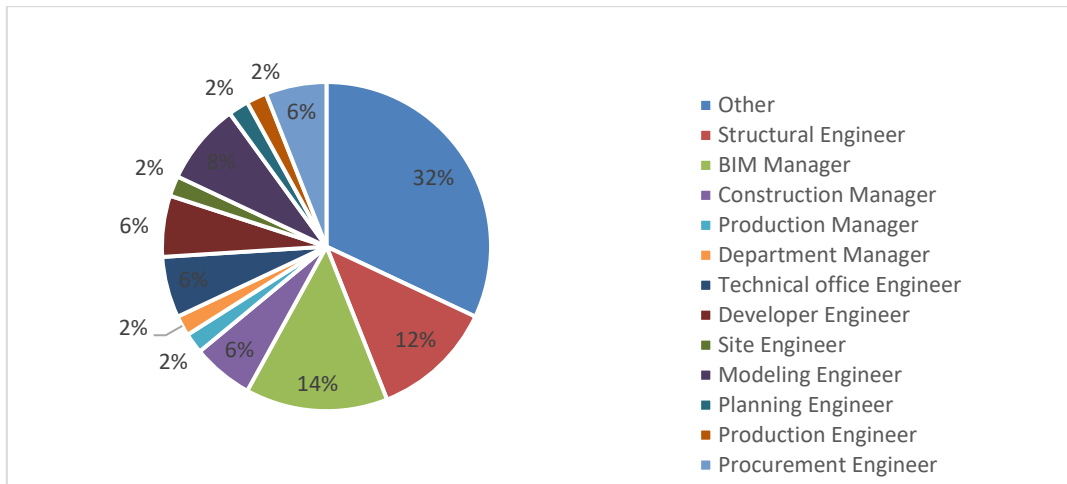

Figure 51: Pie chart illustrating the different roles of the survey participants with the related percentage of each position.

The first rank was the (other) choice; the reason for that is that the survey couldn't include all the roles in the construction industry. Participants who choose "other" are classified into: CEO, BIM Manager with API lead, Steel Detailer, Head of VDC, Project manager, Digital Construction Engineer, Project development director, Cost Control Engineer, Regional Manager, BIM Engineer, BIM coordinator, Precast detailer, Company owner, Business Development, Division Manager on Association. As demonstrated in Table 9, the second rank is BIM managers (14%), followed by Structural engineers (12%).

Role	Count	Percentage	Rank
Other	16	32%	1
BIM Manager	7	14%	2
Structural Engineer	6	12%	3
Modeling Engineer	4	8%	4
Construction Manager	3	6%	5
Technical office Engineer	3	6%	6
Developer Engineer	3	6%	7
Procurement Engineer	3	6%	8
Production Manager	1	2%	9
Department Manager	1	2%	10
Site Engineer	1	2%	11
Planning Engineer	1	2%	12
Production Engineer	1	2%	13
Total	50		

Table 9: The survey participants role ranks and percentages

As shown in Figure 52, 60 % of the responses were collected from Finland, and 15 % were collected from Egypt. The remaining 25% were collected from other countries,

including Germany, Italy, Sweden, the United States and Canada. A detailed rank with the percentage of each country that participated in the survey is illustrated in Table 10.

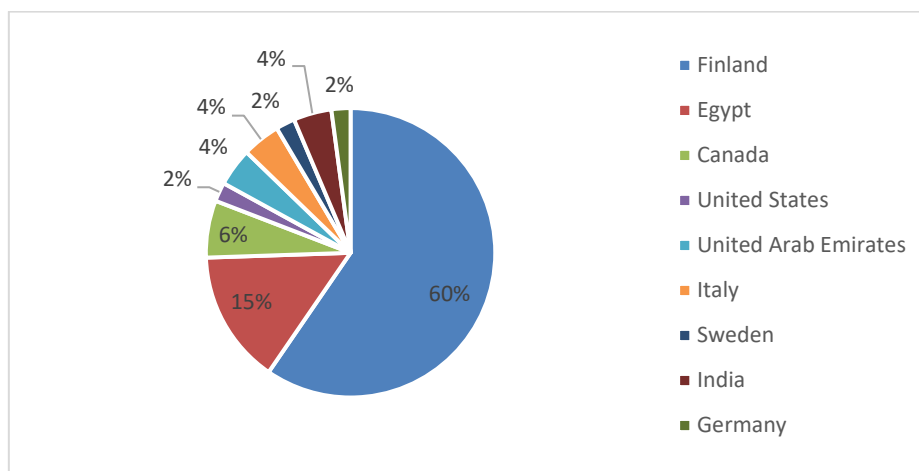

Figure 52: Pie chart showing the participants' country of residence with the related percentage for each country.

Construction Field	Count	Percentage	Rank
Finland	28	60%	1
Egypt	7	15%	2
Canada	3	6%	3
United Arab Emirates	2	4%	4
Italy	2	4%	5
India	2	4%	6
United States	1	2%	7
Sweden	1	2%	8
Germany	1	2%	9
Total	47		

Table 10: Detailed rank with the percentage of each country that participated in the survey.

The weight of Finland (60%) and Egypt (15%) compared to the other countries is almost 75% to 25%. This high percentage reason is that the author focused on the construction market in Finland and Egypt to compare the difference in responses between those particular countries. The other countries' outcome was because of the distribution of the survey on some linked-in pages that included people from different parts of the globe.

As demonstrated in Figure 53 and Table 11, the majority of the participants have work experience between 5 to 25 years. Only a small portion worked in the construction field for more than 25 years, and 22% worked in the field for less than five years. The first two ranks in the table below show that 72% of the participants have a proper background experience, increasing the reliability of their answers.

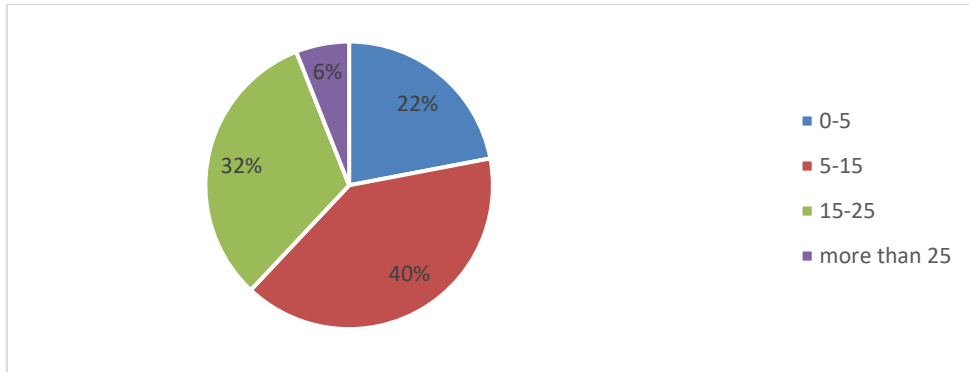

Figure 53: Pie chart illustrating the different years of experiences for the survey participants

Years of Experience	Count	Percentage	Rank
5-15	20	40%	1
15-25	16	32%	2
0-5	11	22%	3
More than 25	3	6%	4
Total	50		

Table 11: Rank for years of experience percentage for the survey participants

Since the survey was focused on big construction companies with experience participants, more than 85% of the responders are working in big companies with more than 200 employees, as illustrated in Figure 54.

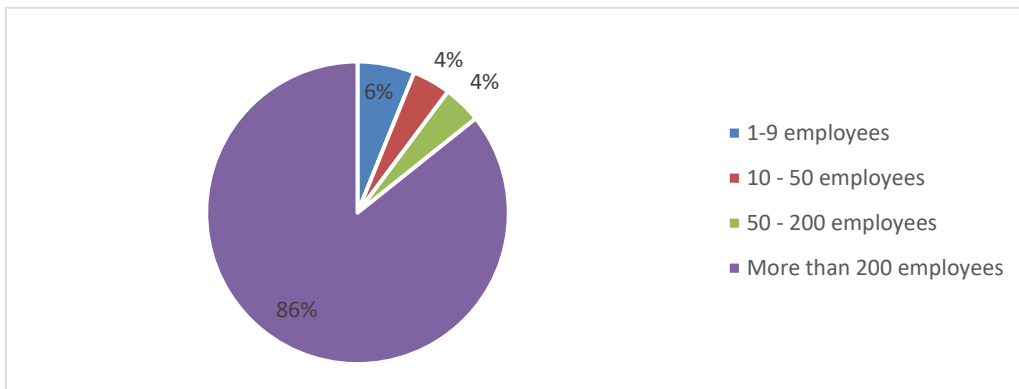

Figure 54: Pie chart showing the percentages of each company size related to the participants.

As demonstrated in the pie chart in Figure 55, many participants range from age 20 to 40. However, more than 30% of the participants have an age range between 40 and 50+ years old. From the rank order shown in Table 12, it was clear that most of the precipitants ages range from ages of 20 to 50 years old (82%).

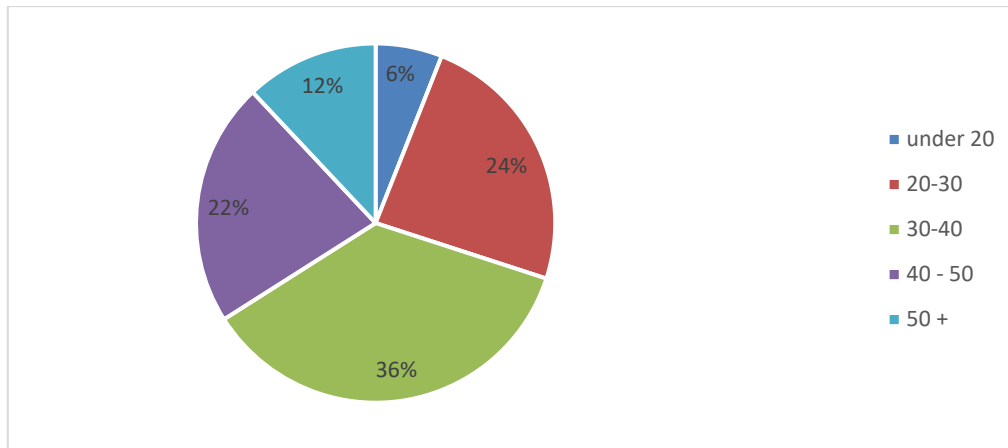

Figure 55: Pie chart illustrating the different age group percentages of the participants

Age (years)	Count	Percentage	Rank
30-40	18	36%	1
20-30	12	24%	2
40 - 50	11	22%	3
50 +	6	12%	4
under 20	3	6%	5
Total	50		

Table 12: The different age group rank and percentage

Analysis and results for the different paperless BIM-based implementation improvements effects and challenges

Different impacts of paperless BIM-based systems implementation on cost, quality and productivity are illustrated in Figure 56. The system has a higher score regarding quality and productivity, with a count of 21 and 27 of “high improvement” choices. The cost highest score was recorded in the “Average improvement” choice with a score of 17 responses.

The different ranks were calculated using the relative importance index equation, as shown in Table 13. From the analysis of the ranks, it's clear that the BIM-based paperless system has the highest improvement effect on productivity (0.85), followed by quality (0.80) and finally the cost (0.72). The author believes that having the productivity and quality of the fabricated units in the first two ranks is due to the system's many advantages in these two aspects. From the author's point of view, the cost improvement effect will increase when the system is widely known and used in the future.

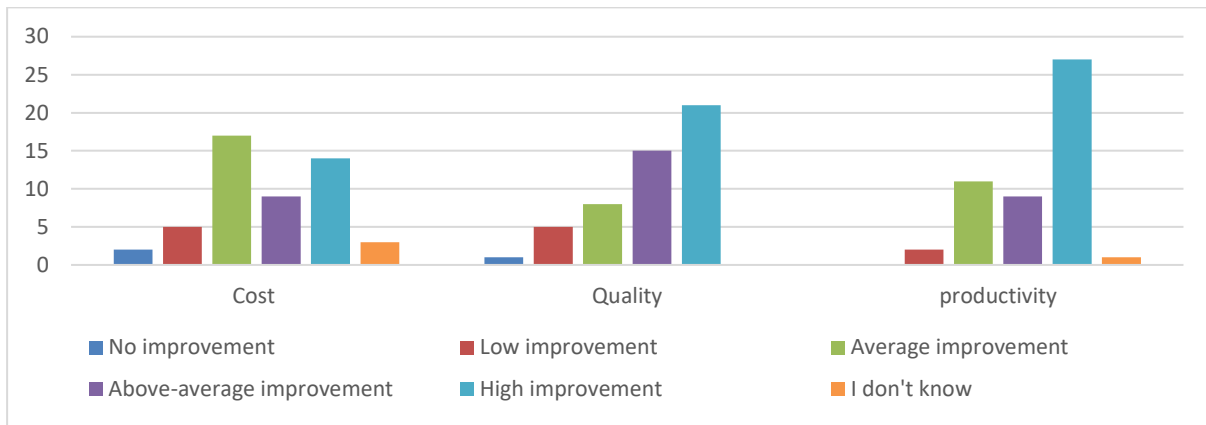

Figure 56: Bar chart showing the participants answers related to the improvement on cost, quality and productivity.

Weight	1	2	3	4	5	0		
Type of elements	No improvement	Low improvement	Average improvement	Above-average improvement	High improvement	I don't know	RII	Rank
productivity	0	2	11	9	27	1	0.85	1
Quality	1	5	8	15	21	0	0.80	2
Cost	2	5	17	9	14	3	0.72	3

Table 13: shows the count of the participant's answers and the related RII and Rank for every element.

Regarding the cost, the author believes that the lower RII (0.72) compared to quality and productivity is related to one main reason. The reason is that the cost of implementing a new system will affect the average profit at the beginning of the project. Through time after stabilizing the new system entirely, the profit will increase, and the cost improvement will grow with it.

The participants were asked about the level of improvement for implementing paperless BIM-based systems on different processes in the fabrication process. The responses show a common view that the system will impact positively as most answers stated that it would have a high improvement impact, as illustrated in Figure 57. The RII calculation in Table 14 was calculated after excluding the "I don't know" answers. Then, the rank was given to the different processes according to their score. From the rank order, production automation (0.867) comes in the first place, followed by progress tracking (0.847) and clash detection (0.846). The lowest RII score was for

Sustainability (0.757), indicating an excellent relation in improvement for the included processes and the BIM-based paperless system.

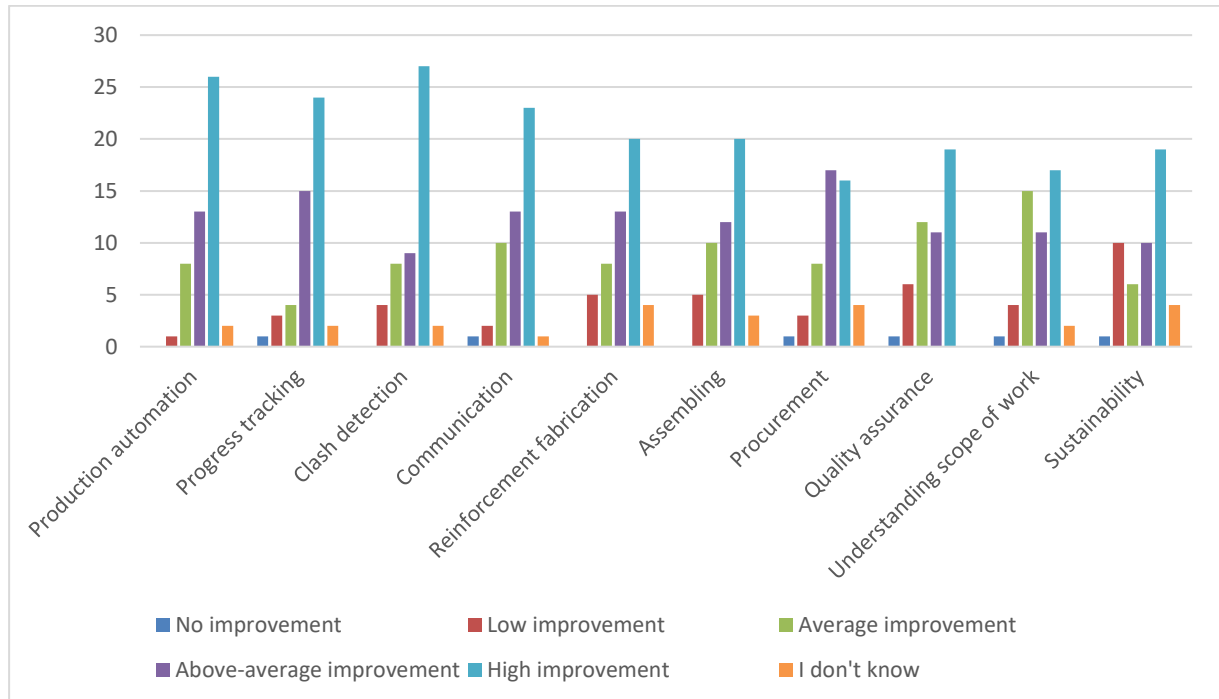

Figure 57: Bar chart showing the participants answers related to each process.

Weight	1	2	3	4	5	0		
Process	No improvement	Low improvement	Average improvement	Above-average improvement	High improvement	I don't know	RII	Rank
Production automation	0	1	8	13	26	2	0.867	1
Progress tracking	1	3	4	15	24	2	0.847	2
Clash detection	0	4	8	9	27	2	0.846	3
Communication	1	2	10	13	23	1	0.824	4
Reinforcement fabrication	0	5	8	13	20	4	0.809	5
Assembling	0	5	10	12	20	3	0.800	6
Procurement	1	3	8	17	16	4	0.796	7
Quality assurance	1	6	12	11	19	0	0.767	8
Understanding scope of work	1	4	15	11	17	2	0.763	9
Sustainability	1	10	6	10	19	4	0.757	10

Table 14: Shows the count of the participant's answers and the related RII and Rank for every process.

Figure 58 shows the different improvements on different structure elements from a complexity point of view. The complex elements have the highest count of 29 responses on the "High improvement" choice. The moderate and simple elements, on

the other hand, have lower responses on the “high improvement” choice with a higher score on the “average improvement” choice.

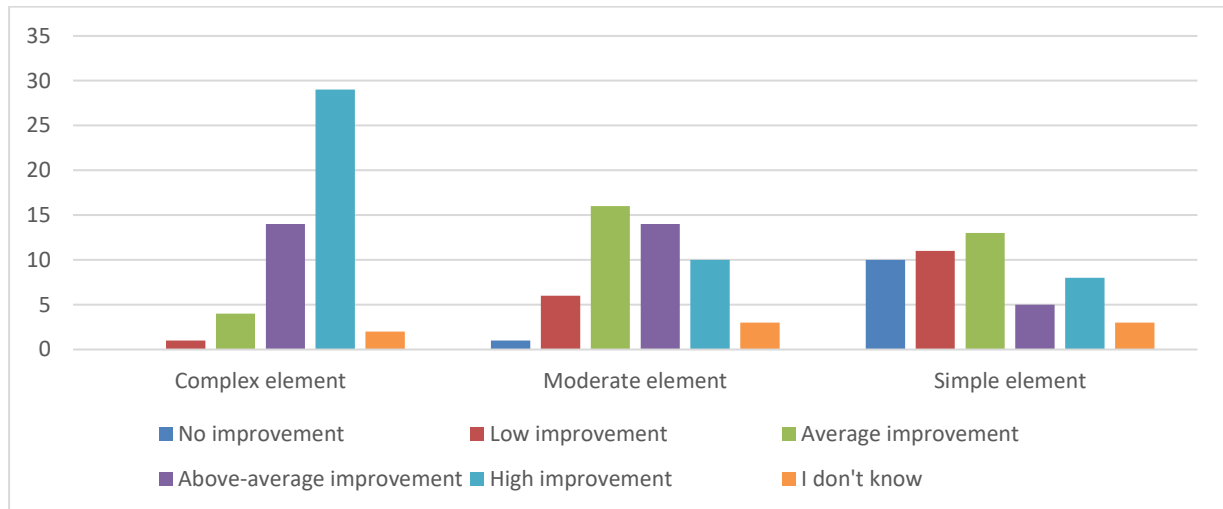

Figure 58: Bar chart showing the participants answers related to the complexity of elements and level of improvement.

As demonstrated in Table 15, the improvement effect on the complex elements comes in the first place. The reason for this high improvement effect on complex elements is that the traditional drawings and traditional methods are not enough in the aspect of efficiency. The paperless BIM-based system will improve the process of the complex elements by better clash detection, assembling and many other improvements, as shown in the previous Table 14.

Weight	1	2	3	4	5	0		
Type of elements	No improvement	Low improvement	Average improvement	Above-average improvement	High improvement	I don't know	RII	Rank
Complex element	0	1	4	14	29	2	0.895	1
Moderate element	1	6	16	14	10	3	0.710	2
Simple element	10	11	13	5	8	3	0.557	3

Table 15: Shows the count of the participant's answers and the related RII and Rank for every element according to its complexity level.

As expected from the author's side, the impact on moderate elements (0.710) came in second place while the simple elements (0.557) was ranked last. The reason for this ranking is that in simple elements and moderate elements, the amount of details and complexity is less. Having this low complexity can be managed using the traditional method. Moreover, using the paperless BIM-based methods in simple elements might

unnecessarily increase the overall process cost in producing small quantities. However, the author recognized a contradiction in results since that production automation was voted to be the most improved process. The simple element shouldn't have this low RII value as most production automation is applied to simple elements.

Regarding the effect of different factors on using the paperless BIM-based system in the fabrication process, the results were collected, as shown in Figure 59. Out of seven different Barriers, lack of experience (0.832) is by far the most related reason for not using paperless BIM-based methods in the construction industry, as shown in Table 16. Fear of change (0.76) comes second, followed by owner involvement (0.729) in the third place. The other reasons for not using the system are not that far away from the relation point of view as they have scored above 0.664 RII. the only barrier that seems to have lower relation to implementing the system is the governmental impact (0.552).

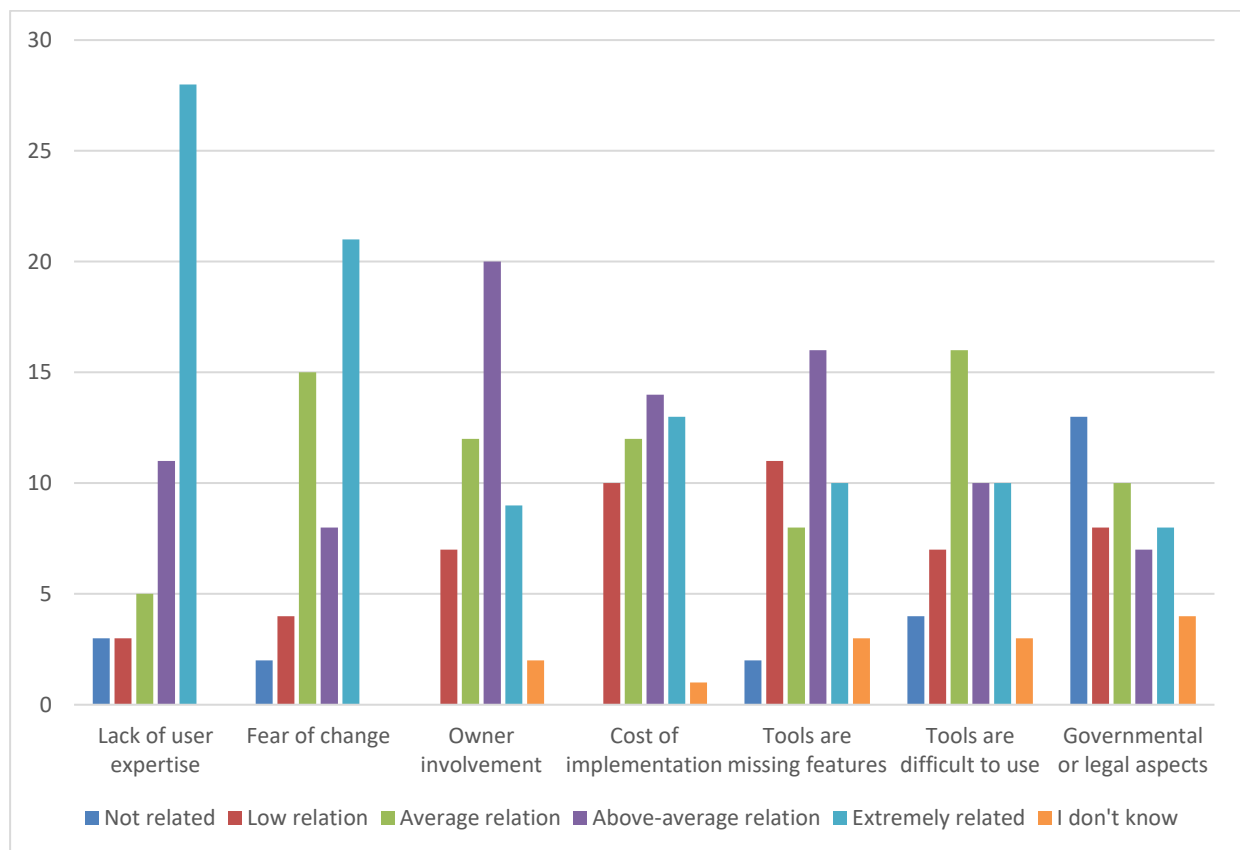

Figure 59: Bar chart showing the participants' answers related to the reasons for not using BIM-based paperless technology.

Weight	1	2	3	4	5	0		
Reasons	Not re- lated	Low rela- tion	Average relation	Above-aver- age relation	Ex- tremely related	I don't know	RII	Rank
Lack of user exper- tise	3	3	5	11	28	0	0.832	1
Fear of change	2	4	15	8	21	0	0.768	2
Owner involvement	0	7	12	20	9	2	0.729	3
Cost of implemen- tation	0	10	12	14	13	1	0.722	4
Tools are missing features	2	11	8	16	10	3	0.689	5
Tools are difficult to use	4	7	16	10	10	3	0.664	6
Governmental or le- gal aspects	13	8	10	7	8	4	0.552	7

Table 16: Shows the count of the participant's answers and the related RII and Rank for every reason related to not using BIM-based paperless technology.

When the participants were asked to illustrate how much they prefer using the system. 62% of the participants stated that they highly prefer using BIM- passed paperless system over the traditional method. Only 2 % prefer using traditional methods, as shown in Figure 60. This percentage indicates that the system is almost ready for implementation in the construction field despite the challenges.

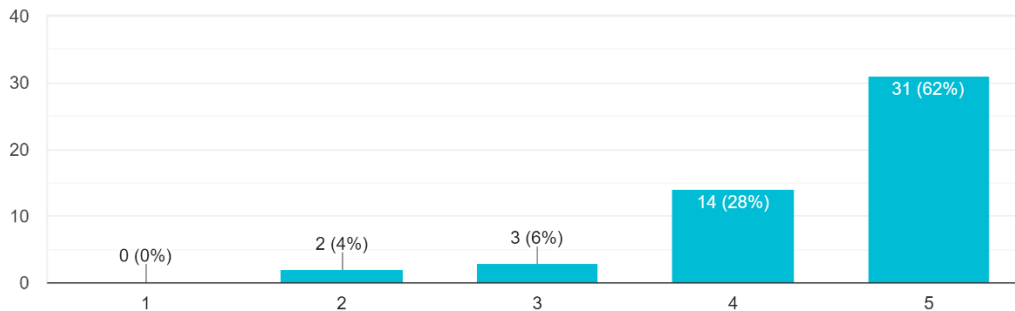

Figure 60: Bar chart shows the percentage of the participants who prefer or don't prefer using the BIM-based paperless system.

BIM-based paperless system usability results and analysis

As illustrated in Figure 61, 68% responded that the external processes require the use of paper drawings and documents even if the internal process were based entirely on paperless, while 32% of the responses oppose this opinion. On the other hand, 86% of the responses stated that the external process could be illustrated on digital devices, and only 14 % indicated that it would need paper-based drawings or documents, as described in Figure 62. From the analysis of the previous answers, the author believes

that the external processes still need improvement in the operational dimension in order to be entirely based on paperless methods compared to the internal processes.

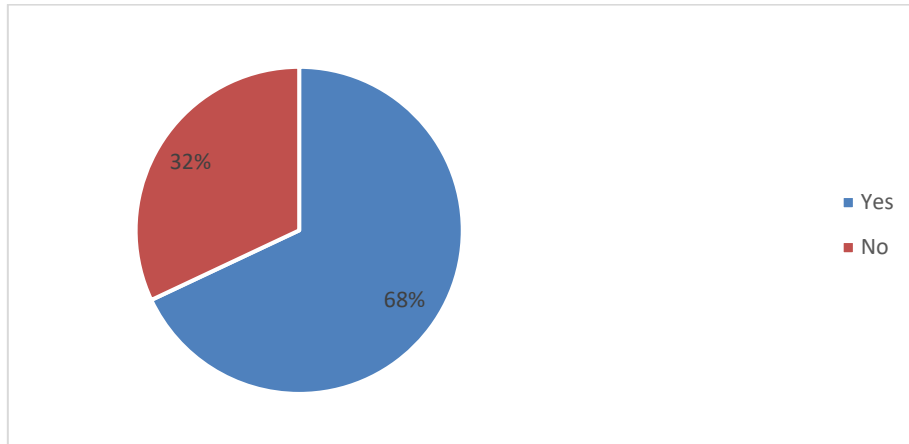

Figure 61: Bar chart showing the percentage of the different answers of the participants regarding the current status for an external process and if it requires a paper document or drawing usage.

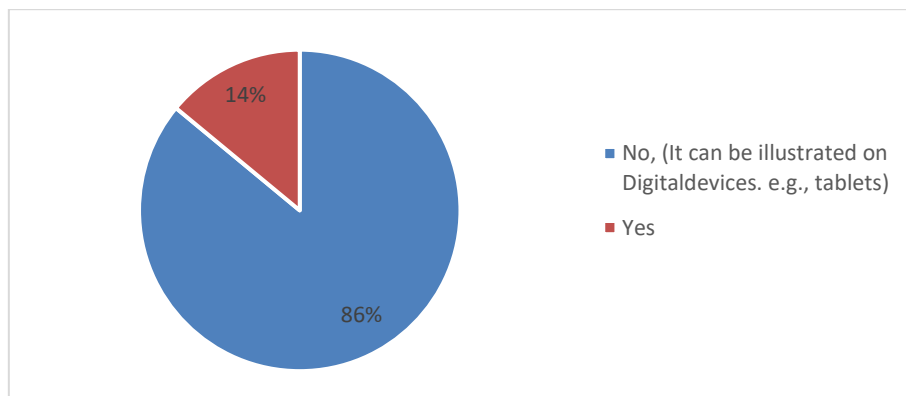

Figure 62: Bar chart showing the percentage of the participants' different answers regarding the external process need for paper-based usage.

Different BIM-based software(s) are used nowadays by different users. The results show that more than one software is being used by the same user, as shown in Figure 63. From the analysis of the results, the most used software(s) by the overall participants are Tekla Structures (76%), Autocade (70%), Trimble Connect (62%), and Solibri (52%). These percentages are also showing the top software(s) adapted for the BIM usage according to the market usage.

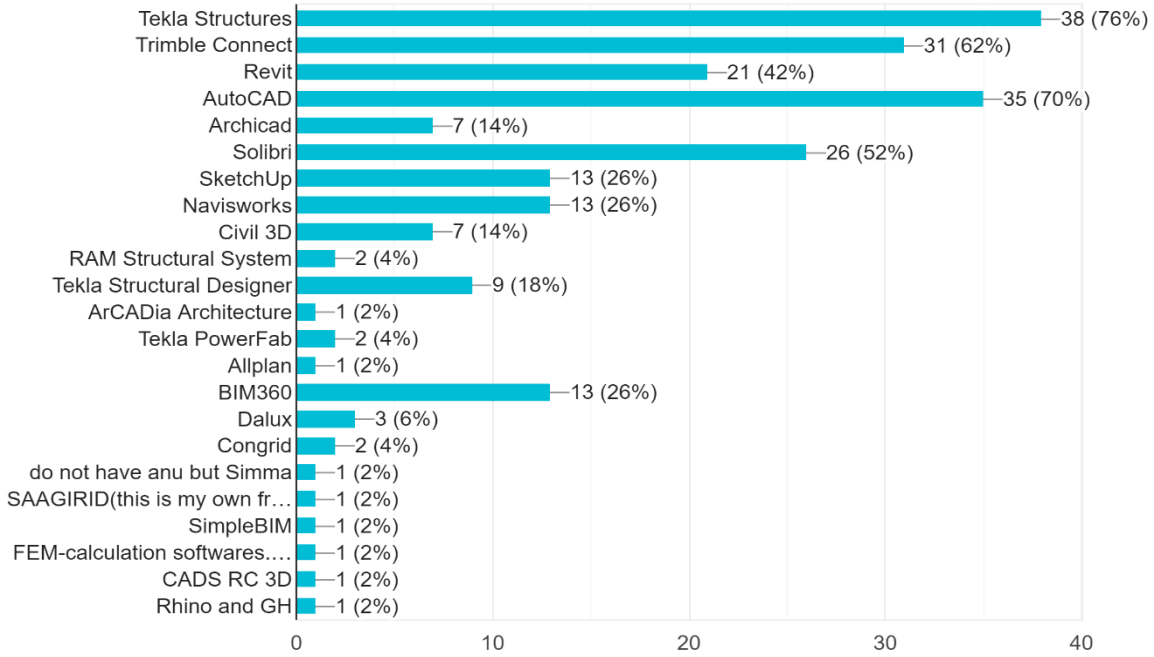

Figure 63: Bar chart showing the different counts and percentages of the software(s) used by the participants.

According to the participant's experience, the paperless system is now used in different construction phases, as shown in Figure 64. From Table 17, there is high usability of the BIM-based paperless methods in Detailing (0.80), Design (0.76), conceptual design (0.74). The survey participants indicate that there is a moderate usage in Manufacturing (0.66), Erection (0.62) and lower use in facility management (0.58).

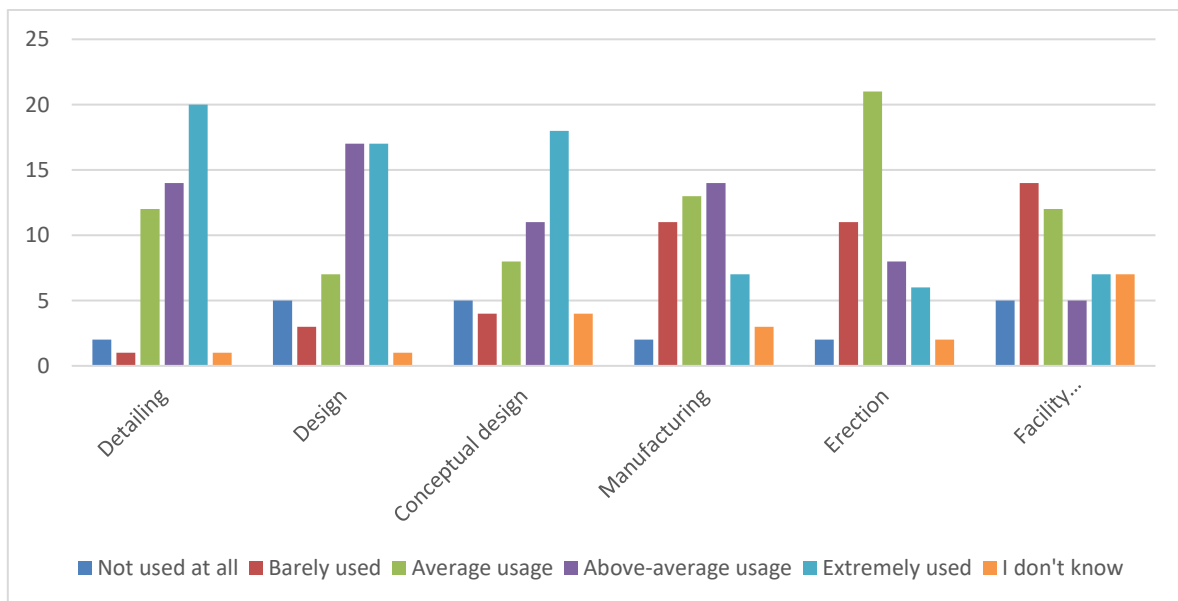

Figure 64: Bar chart showing the participants answers for the different processes that use the BIM-based paperless technology at the moment.

Weight	1	2	3	4	5	0		
phase	Not used at all	Barely used	Average usage	Above-average usage	Extremely used	I don't know	RII	Rank
Detailing	2	1	12	14	20	1	0.80	1
Design	5	3	7	17	17	1	0.76	2
Conceptual design	5	4	8	11	18	4	0.74	3
Manufacturing	2	11	13	14	7	3	0.66	4
Erection	2	11	21	8	6	2	0.62	5
Facility management(Utilization)	5	14	12	5	7	7	0.58	6

Table 17: Shows the count of the participant's answers and the related RII and Rank for every phase usage of the BIM-based paperless system.

72.9% of the precipitation organisation provides infrastructure for a digital-driven fabrication process, as shown in Figure 65. But only 57.8% of the workers on the factory floor or production yard have access to information panels or mobile devices, as illustrated in Figure 66. This indicates that the infrastructure for implementing a complete BIM-based paperless system in factories and companies still need some development.

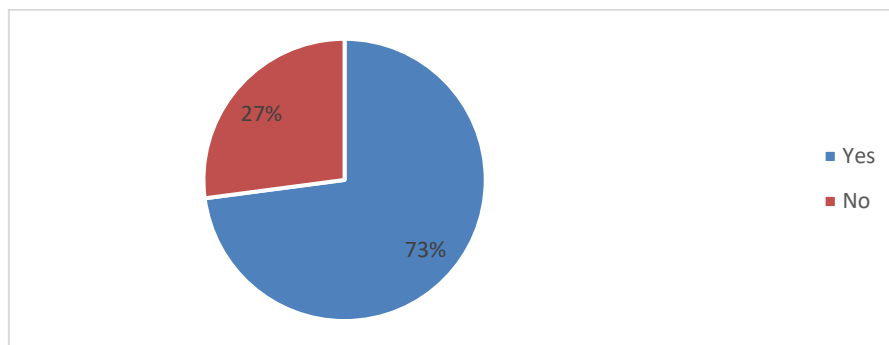

Figure 65: Bar chart showing the percentage of the participants' different answers regarding their organization providing a digital-driven infrastructure for fabrication.

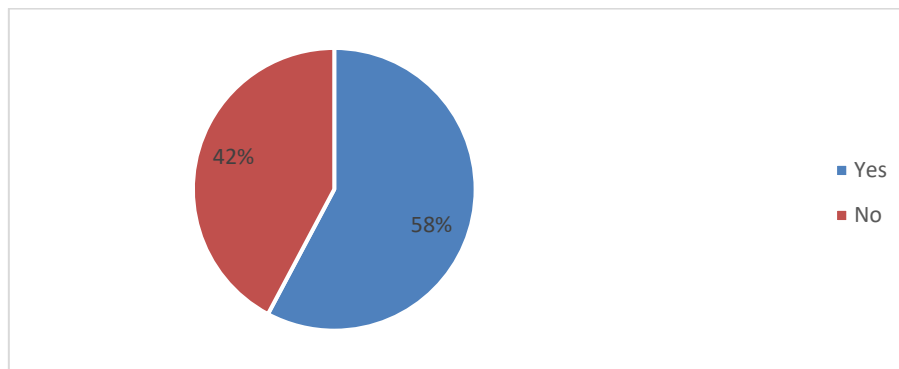

Figure 66: Bar chart showing the percentage of the participants' different answers regarding their organization providing information panels or mobile devices for workers.

More than 50 % of the participants estimate that the paperless system will be widely accepted within three to six years. 18 % thinks that it will take six to nine years, as shown in Figure 67.

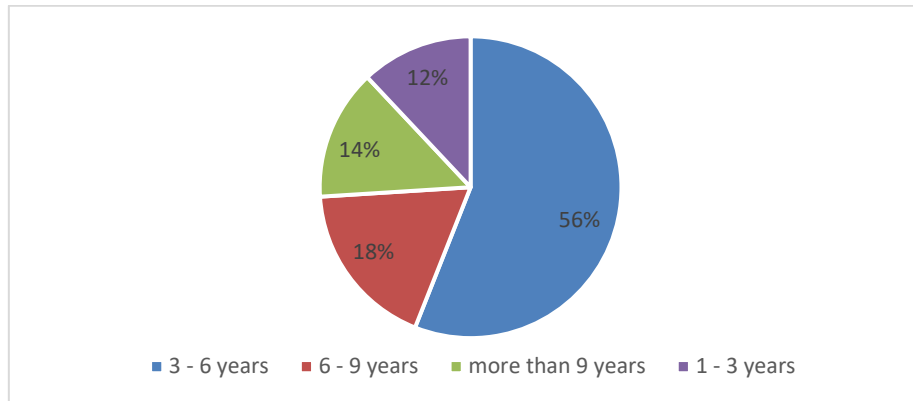

Figure 67: Bar chart showing the percentage of the participants' different answers regarding the number of years needed for widely accepting the paperless system.

5.3.8 Survey conclusion.

The majority of the survey participants are either working in the precast field (38%) or working in other areas, including precast (26%). These percentages were enough to overview how the precast market reacts to the usage of paperless BIM-based methods. Moreover, 60 % of the results are collected from Finland and 25% from Egypt. Another important aspect is that most of the participants have experience from 5 to 25 years. Having this relatively high number of years as experience increased the quality of answers collected. From the company size analysis, it was observed that 86 % of the participants are working in big companies with more than 200 employees.

The effect of paperless BIM-based system on cost, quality and productivity were discussed. It was concluded that the significant improvement would impact the productivity followed by quality and cost. The same rate of improvement is noticed in complex elements, followed by moderate and slight improvement on simple elements.

The participants ranked the different processes according to the level of improvement in every process. Using RII calculations, the process ranks according to the impacted improvement from the implementation of the paperless BIM-based system started with production automation, progress tracking, communication, reinforcement fabrication and assembling with RII higher than 0.8. Procurement, quality assurance, understanding the scope of work and sustainability scored an RII of more than 0.757. these

numbers indicate the approval of the survey participants with the theoretical study in the previous chapters.

Moreover, the challenges presented to the survey participants received a similar response. The most related barriers of not using the paperless system in the construction industry are lack of user experience, fear of change, owner involvement and high cost of implementation with RII higher than 0.722. On the other hand, the participants don't believe that the governmental impact barrier greatly influences the system that contradicts the theoretical study.

Most of the participants (68%) stated that the external processes still need to use paper-based methods even if the internal processes are fully BIM-based. 86% of the participants believe that digital tools can replace the usage of paper-based systems in external processes. Today's most used software(s) from the participant's point of view are Tekla Structures, AutoCad, Solibri, Trimble Connect, Sketchup, Navisworks, and BIM360. The rank analysis for the phases that uses the paperless BIM-based system is ranked starting from the Detailing phase (1), Design (2), conceptual design(3), manufacturing (4), and erection (5). the paperless BIM-based usage in facility management has a low RII of 0.58, which means that the system is currently not widely used in Facility management.

73% of the participants stated that their organizations provide an infrastructure for implementing a digital-driven fabrication process. On the other hand, only 58% stated that the workers in their organization have access to mobile devices or information panels.

Finally, the survey answered the research questions regarding the different BIM-based improvements on different processes and elements. Moreover, the challenges and barriers that the system is facing had been discussed. In the end, the usability of the system in the market today has been analyzed in detail.

6. Conclusion and Discussion

Despite the many advantages of precast concrete technology, there are many barriers that it still faces. Implementing paperless BIM-based methods decreased those barriers by enhancing the whole system. However, new challenges were surfaced when applying this new technology. This study discussed the Advantages and disadvantages of implementing the paperless BIM-based system in the fabrication process.

The main concept of the study was to highlight those advantages and challenges in order to have an overview of the market situation regarding implementing the BIM-based system in the precast concrete and construction industry to overcome its challenges. Moreover, the study provided the know-how of implementing the BIM-based paperless tools in an actual project with some recommendations to solve these challenges.

The suggested research questions helped to build a framework that the author used to collect the important information related to the topic. The precast definition, history, advantages and challenges were discussed in detail in chapter two. For a better understanding of the Paperless BIM-based system, BIM development, different Definitions, usage and different dimensions, benefits, and challenges were covered in chapter three. Furthermore, the BIM-based paperless methods were defined and discussed through the theoretical work, including its different tools, advantages, and barriers.

An actual case study from Norway regarding the implementation of a complete drawing-less project was discussed. The case study included the implementation methods used in the project, analysis for this implementation, including the advantages and challenges. Finally, a survey was distributed to experts in the construction field to understand how the market reacts to BIM-based paperless methods. The survey's main purpose was to confirm or deny the research questions results from the literature and the first case study.

The master thesis research questions were answered in many different chapters in the study's detailed analysis and literature. Moreover, the author is summarizing the answers in the conclusion part to clarify any conflicts that may have been addressed to the readers. The summarized answers are collected from the detailed Literature chapters, the Randselva bridge case study, and the survey results and analysis.

Q1 What are the different BIM-based paperless system improvements to the precast concrete fabrication process? Moreover, what are the challenges of this implementation?

From the theoretical study, the BIM-based paperless system has many improvements in the fabrication process. Quality assurance, 3D modelling and 3D annotation, Clash detection, reinforcement production, and 3D coordination are highly improved using BIM-based Paperless tools. These tools improved the fabrication process by increasing the quality of the products and increasing production accuracy with more flexibility in the coordination between teams. Some challenges are facing these BIM-based paperless tools. The challenges include inaccurate data entry causing model errors, Lack of BIM guidelines, Legal challenges, fear of training cost, lack of experience, and many others.

The results and analysis for the Randselva bridge illustrated many improvements in using the drawing-less system. These improvements include advances in communication, the scope of work understanding, clash detection, augmented reality, and maintenance. However, some difficulties in showing the objects deleted from the model faced the team during the implementation. Moreover, the need for high-quality software to extract the data efficiently was challenging. Finally, difficulties in managing the BIM model with much information and detailed data included.

The survey showed a high relative importance index with a minimum of 0.757 between the presented process improvements and the usage of BIM-based paperless methods. The improvement impacted production automation, progress tracking, clash detection, communication, reinforcement fabrication, Quality assurance and others. Moreover, when the participants were asked about the challenges, six out of seven presented challenges scored RII higher than 0.664 and the Governmental or legal aspect scored 0.552. the presented challenges included Lack of user experience, fear of change, owner involvement, cost of implementation, the complexity of BIM tools and others. These scores mean that those challenges are directly related to not using the BIM-based paperless methods efficiently.

Finally, the answers for the first question with no conflicts is confirmed by the survey, case study, and literature work.

Q2 *How can the paperless system be integrated into the fabrication process?*

The integration of a BIM-based paperless system had been discussed in chapter four and the Randselva bridge case study. An example of the implementations discussed in the theoretical work is using 2D cameras to measure the dimensions of a unit instead of a traditional quality assurance method. Another example is using Trimble Connect in visualization in the manufacturing process by combining the 2D drawings with the 3D model for better visualization during the assembling process.

In the Randselva bridge, the implementation of the system, starting from the design and modelling until the construction phase implementation, were covered. The main idea was to combine the parametric design with the modelling software to be used in the design phase. In the construction phase, different tools were used to facilitate the implementation. BIM stations were used as the BIM tool installed to receive the information and distribute it to the production team. Then the production team viewed this information using tablets (BIM devices) that allowed flexible and fast access to the information on site. Finally, The Site vision tool was used to visualise solutions, process simulation, and information access.

The survey result analysis showed that using BIM-based paperless technology is important for production automation. The production automation scored 0.867 RII. This high RII indicates an excellent improvement rate in production automation when the BIM-based paperless system is implemented. 72% of the participant's organizations provide a digital infrastructure for implementing a complete BIM-based paperless fabrication process. However, only 58% of the participants stated that the workers in their factory have access to digital devices and tools. It is clear that the market still needs some development to be fully ready for a full scale BIM-based paperless implementation. More than 50 % of the participants estimate that the paperless system will be widely accepted within three to six years. 18 % thinks that it will take six to nine years.

Q3 *What is the difference in productivity rate, cost, and quality of the fabrication process after using a paperless system?*

From the theoretical work and Randselva Bridge case study, there was a general understanding that the cost, quality and productivity are improved after using the paperless system. However, there was no specific information stating to what extent they improved or the different improvement effects on them. It was obvious from the study

that productivity and quality are the most improved factors from implementing BIM. These improvement reasons are using different BIM tools that will increase the visualization, ease the communication and enhance the clash detection and many others. The author implemented a direct question in the survey to resolve this vague understanding of the different improvements.

From the survey analysis of the improvement ranks, it's clear that the paperless BIM-based system has the highest improvement effect on productivity (0.85), followed by quality (0.80) and, finally, the cost (0.72).

Q4 What is the different effect of integrating paperless systems on simple, moderate, and complex precast units?

Neither the theoretical work nor the Randselva bridge case study provided the author with a proper answer due to the complexity of the question. The author believes that only a field case study including experimental work on those three types are the only method valid enough to give a clear understanding of the topic. However, the Randselva Bridge team provided the author with a portion of the answer by providing him with the data of fabricating a complex precast concrete unit using BIM-based drawing-less tools. The complex precast concrete structure's design and production process was enhanced by having the 3D model that allowed a better understanding of work scope and faster implementation at the site. This unit's steel cage was produced in 2 working days despite its complexity, even though it was never done before.

The survey analysis provided another source of information regarding the different effects of implementing the paperless system on simple, moderate, and complex precast units. The improvement effect on the complex elements comes in the first place. The reason for this high improvement effect on complex elements is that the traditional drawings and traditional methods are not enough in the aspect of efficiency from the author point of view. The paperless BIM-based system will improve the process of the complex elements by better clash detection, assembling and many other improvements. The impact of using the BIM-based paperless technology on moderate elements (0.710) came in second place, while the simple elements (0.557) was ranked last.

Finally, the study covered all the topic research questions from literature, case study, and the survey.

Recommendations and Future Development

The BIM-based paperless system is currently facing many challenges and barriers. The author believes that the BIM-based paperless methods and tools awareness level is not widely understood based on the study results. More awareness about the system should be included in universities, companies and other related organizations. The awareness can be either by including educational courses regarding the subject in the related programs, training programs for employees with limited knowledge, or/and by supporting the government to adopt the system in the governmental projects.

Furthermore, the construction companies should start providing a level of digitalization in their infrastructure to support the system implementation. The company owners must understand that in order to have a fully operating BIM-based paperless system a capital must be invested at the moment. Investing resources and capital will definitely decrease the cost improvement at the beginning. However, a high-cost improvement will occur after stabilizing the new technology. The reason for the cost improvement is the savings that the construction companies will make due to the BIM-based paperless technology advantages in quality and productivity improvement.

The author believes that Paperless implementation in the precast concrete or the construction field is a broad subject. The paper covered the implementation in the fabrication process and similar areas of construction. Further research regarding erection and logistics phases that have not been covered in this study can provide a broad scope of improvement for the subject. Moreover, the last research question regarding the different improvements that the system impacts the units from a complexity point of view has only been answered briefly. The author recommends a further investigation through a field case study to measure the different effects of implementing the system on different elements with varying levels of complexity.

Declaration of Authorship

I hereby declare that the attached Master's thesis was completed independently and without the prohibited assistance of third parties, and that no sources or assistance were used other than those listed. All passages whose content or wording originates from another publication have been marked as such. Neither this thesis nor any variant of it has previously been submitted to an examining authority or published.

Helsinki, 30.07.2021

Location, Date

Ahmed Ali

Signature of the student

References

- Abbasnejad, B., & Moud, H. I. (2013). BIM and basic challenges associated with its definitions, interpretations, and expectations. *International Journal of Engineering Research and Applications*, 3(2), 287-294.
- AEC, U. (2012). AEC (UK) BIM protocol–Implementing UK BIM standards for the architectural. Engineering and construction industry. Retrieved from <https://aecuk.files.wordpress.com/2012/09/aecukbimprotocol-v2-0.pdf> Accessed April.2021
- Alferieff, D., & Bomba, M. (2019). "Level of Development(LOD) Specification Part I & Commentary for Building Information Models and Data". BIMForum: The US Chapter of BuildingSMART International.
- Alshorafa, R., & Ergen, E. (2019). Determining the level of development for BIM implementation in large-scale projects. *Engineering, Construction and Architectural Management*.
- Ameziane, F. (2000). An information system for building production management. *International Journal of Production Economics*, 64(1-3), 345-358.
- Amoaha, E. K., & Nguyenb, T. V. (2019). Optimizing the usage of Building Information Model (BIM) interoperability focusing on data, not tools. In ISARC. *Proceedings of the International Symposium on Automation and Robotics in Construction (Vol. 36, pp. 1081-1090)*. IAARC Publications.
- Arditi, D., Ergin, U., & Günhan, S. (2000). Factors affecting the use of precast concrete systems. *Journal of architectural engineering*, 6(3), 79-86.
- Azhar, S. (2011). Building Information Modeling (BIM): Trends, benefits, risks, and challenges for the AEC industry. *Leadership and management in engineering*, 11(3), 241-252.
- Azhar, S., Nadeem, A., Mok, J. Y., & Leung, B. H. (2008, August). Building Information Modeling (BIM): A new paradigm for visual interactive modelling and simulation for construction projects. In *Proc., First International Conference on Construction in Developing Countries (Vol. 1, pp. 435-46)*.
- Bd&E Magazine, (2020). No paper trail: Norwegian box girder bridge designed and

constructed solely with BIM, ISSUE, NO. 100, THIRD QUARTER 2020, Available on: <https://www.bridgeweb.com/issue/details/163>. Last visit: 25.07.2021

- Boone, H. N., & Boone, D. A. (2012). Analyzing likert data. *Journal of extension*, 50(2), 1-5.
- Dai, F., & Lu, M. (2010). Assessing the accuracy of applying photogrammetry to take geometric measurements on building products. *Journal of construction engineering and management*, 136(2), 242-250.
- Dineshkumar, N., & Kathirvel, P. (2015). Comparative study on prefabrication construction with cast-in-situ construction of residential buildings. *International Journal of Innovative Science, Engineering & Technology (IJSET)*, 2(4).
- Djassemi, M., & Sena, J. A. (2006). The paperless Factory: A review of issues and technologies. *International Journal of Computer Science and Network Security*, 6(12), 185.
- Dobelis, M. (2013, June). Drawbacks of BIM concept adoption. In *The 12th International Conference on Engineering Graphics BALTGRAF* (pp. 5-7)
- Eastman, C. M., & Siabiris, A. (1995). A generic building product model was incorporating building type information. *Automation in construction*, 3(4), 283-304.
- Eastman, C. M., Eastman, C., Teicholz, P., Sacks, R., & Liston, K. (2011). *BIM handbook: A guide to building information modelling for owners, managers, designers, engineers, and contractors*. John Wiley & Sons.
- Eastman, C., & Henrion, M. (1977). GLIDE: a language for design information systems. *ACM SIGGRAPH Computer Graphics*, 11(2), 24-33.
- Eastman, C., Lividini, J., & Stoker, D. (1975, May). A database for designing large physical systems. In *Proceedings of the May 19-22, 1975, national computer conference and exposition* (pp. 603-611).
- ELEMATIC and Eilola, j., (2020). Smart Solutions for Precast Concrete Production. Elematic Presentation on Mar. 9, 2020. Retrieved from an email sent by Jani.Eilola@elematic.com, after taking his authorized permission.
- Fai, S., & Rafeiro, J. (2014). Establishing an appropriate level of detail (LoD) for a building information model (BIM)-West Block, Parliament Hill, Ottawa, Canada. ISPRS

Annals of the Photogrammetry, Remote Sensing and Spatial Information Sciences, 2(5), 123.

Fernandes, R. P. L. (2013). Advantages and disadvantages of BIM platforms on construction site.

Gardezi, S. S. S., Shafiq, N., Nuruddin, M. F., Farhan, S. A., & Umar, U. A. (2014). Challenges for implementation of building information modelling (BIM) in the Malaysian construction industry. In *Applied Mechanics and Materials* (Vol. 567, pp. 559-564). Trans Tech Publications Ltd.

Gliem, J. A., & Gliem, R. R. (2003). Calculating, interpreting, and reporting Cronbach's alpha reliability coefficient for Likert-type scales. Midwest Research-to-Practice Conference in Adult, Continuing, and Community Education.

Grubert, J., Langlotz, T., Zollmann, S., & Regenbrecht, H. (2016). Towards pervasive augmented reality: Context-awareness in augmented reality. *IEEE transactions on visualization and computer graphics*, 23(6), 1706-1724.

Gündüz, M., Nielsen, Y., & Özdemir, M. (2013). Quantification of delay factors using the relative importance index method for construction projects in Turkey. *Journal of management in engineering*, 29(2), 133-139.

Hackman, T., Lindgren, J., Rackow, K., & Snyder, C. (2004). Paperless construction: How contractors can adjust to change in the industry.

Hardin, B., & McCool, D. (2015). *BIM and construction management: proven tools, methods, and workflows*. John Wiley & Sons.

Hergunsel, M. F. (2011). Benefits of building information modelling for construction managers and BIM-based scheduling.

Jalali, S. (2018). Use of BIM Technology and 3D-Modeling to Automate the Paperless Reinforcement Production (Master's thesis, Universitetet I Agder; University of Agder).

Kamardeen, I. (2010, September). 8D BIM modelling tool for accident prevention through design. In 26th annual ARCOM conference (Vol. 1, pp. 281-289). Leeds: Association of Researchers in Construction Management.

Kaner, I., Sacks, R., Kassian, W., & Quitt, T. (2008). Case studies of BIM adoption for

precast concrete design by mid-sized structural engineering firms. *Journal of Information Technology in Construction (ITcon)*, 13(21), 303-323.

- Kanungo, T., Haralick, R. M., & Dori, D. (1995, August). Understanding engineering drawings: A survey. In *Proceedings of First IARP Workshop on Graphics Recognition* (pp. 217-228).
- Kenley, R., & Seppänen, O. (2006). *Location-based management for construction: Planning, scheduling, and control*. Routledge.
- Kim, M. K., Wang, Q., Park, J. W., Cheng, J. C., Sohn, H., & Chang, C. C. (2016). Automated dimensional quality assurance of full-scale precast concrete elements using laser scanning and BIM. *Automation in Construction*, 72, 102-114.
- Koseoglu, O., & Nurtan-Gunes, E. T. (2018). Mobile BIM implementation and lean interaction on construction site: A case study of a complex airport project. *Engineering, Construction and Architectural Management*.
- Kravchenko, O. (2020). *BIM in Construction Management: Based on Trimble Solutions products*.
- Ku, K., & Taiebat, M. (2011). BIM experiences and expectations: the constructors' perspective. *International Journal of Construction Education and Research*, 7(3), 175-197.
- Kumar, R., Patterson, M., & Jain, S. (2016). A case study on the use of Precast technology for the construction of High-Rise Buildings. *NTPC Global Energy Technology Summit*, New Delhi, India.
- Latiffi, A. A., Brahim, J., & Fathi, M. S. (2014). The development of building information modelling (BIM) definition. In *Applied mechanics and materials* (Vol. 567, pp. 625-630). Trans Tech Publications Ltd.
- Latiffi, A. A., Brahim, J., Mohd, S., & Fathi, M. S. (2015). Building Information Modeling (BIM): exploring level of development (LOD) in construction projects. In *Applied mechanics and materials* (Vol. 773, pp. 933-937). Trans Tech Publications Ltd.
- Lee, J. S., Kwon, N., Ham, N. H., Kim, J. J., & Ahn, Y. H. (2019). BIM-Based Digital Fabrication Process for a Free-Form Building Project in South Korea. *Advances in Civil Engineering*, 2019.

- Leite, F., Akcamete, A., Akinci, B., Atasoy, G., & Kiziltas, S. (2011). Analysis of modelling effort and impact of various levels of detail in building information models. *Automation in construction*, 20(5), 601-609.
- Lévy, F. (2011). *BIM in small-scale sustainable design*. John Wiley & Sons.
- Lisa Russell, (August 2019). BIM for bridges, *The Construction Index Magazine*, July/August 2019. Available on: <https://www.theconstructionindex.co.uk/news/view/bim-for-bridges>. Last visit: 25.07.2021
- Liu, Z. (2010). *Feasibility Analysis of BIM Based Information System for Facility Management at WPI (Doctoral dissertation, Worcester Polytechnic Institute.)*.
- Luiten, G. T., Tolman, F. P., & Fischer, M. A. (1998). Project-modelling in AEC to integrate design and construction. *Computers in Industry*, 35(1), 13-29.
- Maciel, A. R., & Corrêa, F. R. (2016). Interoperability with IFC in the automated rebar fabrication. In ISARC. *Proceedings of the International Symposium on Automation and Robotics in Construction (Vol. 33, p. 1)*. IAARC Publications.
- Masood, R., Kharal, M. K. N., & Nasir, A. R. (2014). Is BIM adoption advantageous for the construction industry of Pakistan?. *Procedia Engineering*, 77, 229-238.
- Matipa, W. M., Kelliher, D., & Keane, M. (2008). How a quantity surveyor can ease cost management at the design stage using a building product model. *Construction Innovation*.
- Mavreli, E. (2018). *Level of Development vs Level of Detail for BIM*. TUM, Munich.
- Mohamed Hossam, T. A., Eid, A. F., & Khodeir, L. (2019). Identifying The Impact Of Integrating Building Information Modeling with Maintenance Management A Literature Review. *Journal of Al-Azhar University Engineering Sector*, 14(51), 627-641.
- Mostafa, S., Kim, K. P., Tam, V. W., & Rahnamayiezekavat, P. (2020). Exploring the status, benefits, barriers, and opportunities of using BIM for advancing prefabrication practice. *International Journal of Construction Management*, 20(2), 146-156.
- Murari, S. S., & Joshi, A. M. (2017). *Precast Construction Methodology in Construction Industry*. Available at SSRN 3496019.
- Mushhad, S., Gilani, M., Ahmed, J., & Abbas, M. A. (2009, August). Electronic document management: a paperless university model. In 2009 2nd IEEE International

Conference on Computer Science and Information Technology (pp. 440-444). IEEE.

- Nanyam, V. N., Basu, R., Sawhney, A., Vikram, H., & Lodha, G. (2017). Implementation of precast technology in India—opportunities and challenges. *Procedia Engineering*, 196, 144-151.
- National BIM Standard Project Committee. (2007). National building information modelling standard, version 1, Part 1: Overview, principles, and methodologies. National Institute of Building Sciences.
- Nourbakhsh, M., Zin, R. M., Irizarry, J., Zolfagharian, S., & Gheisari, M. (2012). Mobile application prototype for on-site information management in the construction industry. *Engineering, Construction, and Architectural Management*.
- Oli, A. (2017). Structural BIM Modelling Using Tekla Structures: Focus on a Modelling Process of an Office Building.
- Ordóñez, C., Arias, P., Herráez, J., Rodríguez, J., & Martín, M. T. (2008). Two photogrammetric methods for measuring flat elements in buildings under construction. *Automation in Construction*, 17(5), 517-525.
- Park, J. (2011). BIM-based parametric design methodology for modernized Korean traditional buildings. *Journal of Asian Architecture and Building Engineering*, 10(2), 327-334.
- Park, S., & Kim, I. (2015). BIM-based quality control for safety issues in the design and construction phases. *ArchNet-IJAR: International Journal of Architectural Research*, 9(3), 111.
- Peng, W., & Pheng, L. S. (2011). Lean production, value chain and sustainability in precast concrete factory—a case study in Singapore. *Lean Construction Journal*, 2010, 92-109.
- Polat, G. (2008). Factors affecting the use of precast concrete systems in the United States. *Journal of Construction Engineering and Management*, 134(3), 169-178.
- PRASAD, H. V., & PRASAD, H. R. (2015). Case study on conventional and fast track construction techniques. *International Journal of Science, Engineering & Technology*, 3(5).

- Preidel, C., Borrmann, A., Oberender, C., & Tretheway, M. (2017). Seamless integration of common data environment access into BIM authoring applications: The BIM integration framework. In *eWork and eBusiness in Architecture, Engineering and Construction* (pp. 119-128). CRC Press.
- Priya, P. K., & Neamitha, M. (2018). A review on precast concrete. *International Journal of Engineering and Technology (IRJET)*, 5(1).
- Ratajczak, J., Riedl, M., & Matt, D. T. (2019). BIM-based and AR application combined with location-based management system for the improvement of the construction performance. *Buildings*, 9(5), 118.
- Sabol, L. (2008). Challenges in cost estimating with Building Information Modeling. *IFMA World Workplace*, 1-16.
- Sacks, R., Eastman, C. M., & Lee, G. (2004). Process model perspectives on management and engineering procedures in the precast/prestressed concrete industry. *Journal of Construction Engineering And Management*, 130(2), 206-215.
- Sadeghi, M., Elliott, J. W., Porro, N., & Strong, K. (2019). Developing building information models (BIM) for building handover, operation, and maintenance. *Journal of Facilities Management*.
- Santos, R., Costa, A. A., & Grilo, A. (2017). Bibliometric analysis and review of Building Information Modelling literature published between 2005 and 2015. *Automation in Construction*, 80, 118-136.
- Seo, J. C., Kim, H. J., & Kim, I. H. (2012). Open BIM-based quality control for enhancing the design quality in the architectural design phase. *Korean Journal of Construction Engineering and Management*, 13(4), 3-15.
- Smith, P. (2014). BIM & the 5D project cost manager. *Selected Papers From The 27th IPMA (International Project Management Association)*.
- Taherdoost, H. (2016). Validity and reliability of the research instrument; how to test the validation of a questionnaire/survey in a research. How to test the validation of a questionnaire/survey in a research (August 10, 2016).
- Tan, T., Chen, K., Xue, F., & Lu, W. (2019). Barriers to Building Information Modeling (BIM) implementation in China's prefabricated construction: An interpretive structural modelling (ISM) approach. *Journal of Cleaner Production*, 219, 949-959.

- Thompson, D. B., & Miner, R. G. (2006). Building Information Modeling-BIM: Contractual risks are changing with technology. WWW document] URL <http://www.aepronet.org/ge/no35.html>
- Thorsten, H. , Sakari, L., Andy, D., Tiina L, (2021, march). Tekla 2021 - What's New for Precast (Webinar). Trimble. <https://www.tekla.com/us/about/webinars/video/tekla-2021-whats-new-precaster>. Last visit: 25.07.2021
- Tulke, J., & Hanff, J. (2007, June). 4D construction sequence planning–new process and data model. In Proceedings of CIB-W78 24th International Conference on Information Technology in Construction, Maribor, Slovenia (pp. 79-84).
- Underwood, J., & Isikdag, U. (Eds.). (2009). Handbook of research on building information modelling and construction informatics: Concepts and technologies: Concepts and technologies. IGI Global.
- Valkoniemi, L. (2019). Changing the Paradigm of Drawing Consumption.
- VanGeem, M. (2006). Achieving sustainability with precast concrete. PCI Journal, 51(1), 42.
- Wang, X., Love, P. E., & Davis, P. R. (2012). BIM+ AR: a framework for bringing BIM to the construction site. In Construction Research Congress 2012: Construction Challenges in a Flat World (pp. 1175-1181).
- Yee, A. A., & Eng, P. H. D. (2001). Social and environmental benefits of precast concrete technology. PCI Journal, 46(3), 14-19.
- Yin, X., Liu, H., Chen, Y., Wang, Y., & Al-Hussein, M. (2020). A BIM-based framework for operation and maintenance of utility tunnels. Tunnelling and Underground Space Technology, 97, 103252.

Appendix

Study survey

BIM Based Paperless Solutions Impact

Thank you for taking the time to participate in this questionnaire. This questionnaire is conducted to analyze Paperless BIM-based process usage, advantages, and challenges in the fabrication process.

A paperless process is replacing a paper-based traditional process using digital BIM-based models (drawings-less systems); it also includes the use of paperless drawings (e.g., PDF) instead of paper-based drawings.

By answering this survey, you agree that the data collected will be used in developing the current BIM-based tools by Trimble, also as a case study for a master thesis paper of Ahmed Ali.

* Required

Email *

Your email _____

What field of construction do you belong to? Note: All the following questions analysis will be related to the field of construction chosen in this question.

Precast concrete

Steel

Cast in situ

Timber

Other: _____

What do you think is the level of improvement that the paperless process implementation has on each of the following processes in fabrication?

	No improvement	Low improvement	Average Improvement	Above-Average Improvement	High improvement
Quality assurance	<input type="radio"/>	<input type="radio"/>	<input type="radio"/>	<input type="radio"/>	<input type="radio"/>
Clash detection	<input type="radio"/>	<input type="radio"/>	<input type="radio"/>	<input type="radio"/>	<input type="radio"/>
Procurement	<input type="radio"/>	<input type="radio"/>	<input type="radio"/>	<input type="radio"/>	<input type="radio"/>
Communication	<input type="radio"/>	<input type="radio"/>	<input type="radio"/>	<input type="radio"/>	<input type="radio"/>
Understanding scope of work	<input type="radio"/>	<input type="radio"/>	<input type="radio"/>	<input type="radio"/>	<input type="radio"/>
Production automation	<input type="radio"/>	<input type="radio"/>	<input type="radio"/>	<input type="radio"/>	<input type="radio"/>
Progress tracking	<input type="radio"/>	<input type="radio"/>	<input type="radio"/>	<input type="radio"/>	<input type="radio"/>
Reinforcement fabrication	<input type="radio"/>	<input type="radio"/>	<input type="radio"/>	<input type="radio"/>	<input type="radio"/>
Sustainability	<input type="radio"/>	<input type="radio"/>	<input type="radio"/>	<input type="radio"/>	<input type="radio"/>
Assembling	<input type="radio"/>	<input type="radio"/>	<input type="radio"/>	<input type="radio"/>	<input type="radio"/>



What do you think is the level of improvement that the paperless process implementation has on each of the following processes in fabrication?

	No improvement	Low improvement	Average Improvement	Above-Average Improvement	High improvement	I don't know
Quality assurance	<input type="radio"/>	<input type="radio"/>	<input type="radio"/>	<input type="radio"/>	<input type="radio"/>	<input type="radio"/>
Clash detection	<input type="radio"/>	<input type="radio"/>	<input type="radio"/>	<input type="radio"/>	<input type="radio"/>	<input type="radio"/>
Procurement	<input type="radio"/>	<input type="radio"/>	<input type="radio"/>	<input type="radio"/>	<input type="radio"/>	<input type="radio"/>
Communication	<input type="radio"/>	<input type="radio"/>	<input type="radio"/>	<input type="radio"/>	<input type="radio"/>	<input type="radio"/>
Understanding scope of work	<input type="radio"/>	<input type="radio"/>	<input type="radio"/>	<input type="radio"/>	<input type="radio"/>	<input type="radio"/>
Production automation	<input type="radio"/>	<input type="radio"/>	<input type="radio"/>	<input type="radio"/>	<input type="radio"/>	<input type="radio"/>
Progress tracking	<input type="radio"/>	<input type="radio"/>	<input type="radio"/>	<input type="radio"/>	<input type="radio"/>	<input type="radio"/>
Reinforcement fabrication	<input type="radio"/>	<input type="radio"/>	<input type="radio"/>	<input type="radio"/>	<input type="radio"/>	<input type="radio"/>
Sustainability	<input type="radio"/>	<input type="radio"/>	<input type="radio"/>	<input type="radio"/>	<input type="radio"/>	<input type="radio"/>
Assembling	<input type="radio"/>	<input type="radio"/>	<input type="radio"/>	<input type="radio"/>	<input type="radio"/>	<input type="radio"/>



How would you describe the improvement of a paperless process implementation on different structure elements from the complexity point of view?

	No improvement	Low improvement	Average improvement	Above-average improvement	High improvement	I don't know
Simple element	<input type="radio"/>	<input type="radio"/>	<input type="radio"/>	<input type="radio"/>	<input type="radio"/>	<input type="radio"/>
Moderate element	<input type="radio"/>	<input type="radio"/>	<input type="radio"/>	<input type="radio"/>	<input type="radio"/>	<input type="radio"/>
Complex element	<input type="radio"/>	<input type="radio"/>	<input type="radio"/>	<input type="radio"/>	<input type="radio"/>	<input type="radio"/>

Could you estimate the relation between the following reasons and not using a BIM-based paperless process in the fabrication process?

	Not related	Low relation	Average relation	Above-average relation	Extremely related	I don't know
Lack of user expertise	<input type="radio"/>	<input type="radio"/>	<input type="radio"/>	<input type="radio"/>	<input type="radio"/>	<input type="radio"/>
Fear of change	<input type="radio"/>	<input type="radio"/>	<input type="radio"/>	<input type="radio"/>	<input type="radio"/>	<input type="radio"/>
Cost of implementation	<input type="radio"/>	<input type="radio"/>	<input type="radio"/>	<input type="radio"/>	<input type="radio"/>	<input type="radio"/>
Owner involvement	<input type="radio"/>	<input type="radio"/>	<input type="radio"/>	<input type="radio"/>	<input type="radio"/>	<input type="radio"/>
Tools are missing features	<input type="radio"/>	<input type="radio"/>	<input type="radio"/>	<input type="radio"/>	<input type="radio"/>	<input type="radio"/>
Governmental or legal aspects	<input type="radio"/>	<input type="radio"/>	<input type="radio"/>	<input type="radio"/>	<input type="radio"/>	<input type="radio"/>
Tools are difficult to use	<input type="radio"/>	<input type="radio"/>	<input type="radio"/>	<input type="radio"/>	<input type="radio"/>	<input type="radio"/>

What other challenges do you think could affect the implementation process?

Your answer _____

Paperless Implementation

How much do you prefer BIM-based solutions over traditional Methods?

- 1 2 3 4 5
- I do not prefer it at all I prefer it a lot

Do you think that the external processes will require any paper drawings or documents, even if the internal processes are based on paperless only?

- Yes
- No

Do you think that the external processes paper-based drawings and documents need to be illustrated in paper-based format only?

- No, (It can be illustrated on Digital devices. e.g., tablets)
- Yes

What kind of paperless BIM-based solutions tool do you use in your field?

- Tekla Structures
- Trimble Connect
- Revit
- AutoCAD
- Archicad
- Solibri
- SketchUp
- Navisworks
- Civil 3D
- RAM Structural System
- Tekla Structural Designer
- ArCADia Architecture
- Tekla PowerFab
- Allplan
- BIM360
- Other: _____

According to your experience, how much is the paperless process used now in each of the following phases? (Used generally or in your organization)

	Not used at all	Barely used	Average usage	Above-average usage	Extremely used	I don't know
Conceptual design	<input type="radio"/>	<input type="radio"/>	<input type="radio"/>	<input type="radio"/>	<input type="radio"/>	<input type="radio"/>
Design	<input type="radio"/>	<input type="radio"/>	<input type="radio"/>	<input type="radio"/>	<input type="radio"/>	<input type="radio"/>
Detailing	<input type="radio"/>	<input type="radio"/>	<input type="radio"/>	<input type="radio"/>	<input type="radio"/>	<input type="radio"/>
Manufacturing	<input type="radio"/>	<input type="radio"/>	<input type="radio"/>	<input type="radio"/>	<input type="radio"/>	<input type="radio"/>
Erection	<input type="radio"/>	<input type="radio"/>	<input type="radio"/>	<input type="radio"/>	<input type="radio"/>	<input type="radio"/>
Facility management (Utilization)	<input type="radio"/>	<input type="radio"/>	<input type="radio"/>	<input type="radio"/>	<input type="radio"/>	<input type="radio"/>

Does your organization/factory provide the infrastructure for a digitally-driven fabrication process regarding a paperless workflow?

Yes

No

Do the workers on the factory floor have access to information panels (e.g., large screens) or have access to mobile devices (e.g., tablets)?

Yes

No

What is your estimate when the paperless process is widely accepted and used?

- 1 - 3 years
- 3 - 6 years
- 6 - 9 years
- more than 9 years

BIM Based Paperless Solutions Impact

Background Information

What is the country of your current residence?

Choose 

How many years have you been working in this industry?

- 0-5
- 5-15
- 15-25
- more than 25

How would you describe your current company size?

- 1-9 employees
- 10 - 50 employees
- 50 - 200 employees
- More than 200 employees

What is your role in Construction?

 ▼

If you answered other in the previous question, please specify your role.

Your answer _____

What age group do you belong to?

- under 20
- 20-30
- 30-40
- 40 - 50
- 50 +
- Other: _____

Are you willing to have a voluntary interview regarding the topic?

Yes

No

Any other comments?

Your answer
