

Bachelor's thesis

Information Technology

2015

Wenqi Chen

RADIO FREQUENCY IDENTIFICATION TECHNOLOGY AND APPLICATIONS



TURUN AMMATTIKORKEAKOULU
TURKU UNIVERSITY OF APPLIED SCIENCES

BACHELOR'S THESIS | ABSTRACT
TURKU UNIVERSITY OF APPLIED SCIENCES

Information Technology | Internet technology

June 2015|37

Patric Granholm

Wenqi Chen

RADIO FREQUENCY IDENTIFICATION TECHNOLOGY AND APPLICATIONS

RFID technology is a pattern of automatic identification and a kind of wireless communication technology. It can be applied to different aspects in our life. RFID technology has developed rapidly in the recent years and has enabled the use of low cost electronic tags (EPC). RFID technology is expected to develop into a huge internet of things in the future. Therefore, it has a great potential in the new information age.

This thesis introduces the system structure, operating principles, application areas and development trends of RFID technology, discusses the Electronic Toll Collection system as an application of RFID technology and reflects on the future of RFID.

KEYWORDS:

RFID system, ETC, EPC, IC chip, antenna, integrated circuit, reader-writer, radio frequency

CONTENTS

LIST OF ABBREVIATIONS (OR) SYMBOLS	5
1 INTRODUCTION	6
2 RFID TECHNOLOGY SYSTEM	7
2.1 Basic Concept of RFID	7
2.2 The System Structure and operation principle of RFID	9
2.2.1 The key technology of RFID	11
2.2.2 The EPC	13
2.2.3 The reader-writer	20
2.3 The Frequency Choice	23
2.4 RFID industry chain	25
2.4.1 The production process of EPC	26
2.4.2 The reader-writer machines and tools	29
3 APPLICATIONS OF RFID	30
3.1 The application range of RFID	30
3.2 ETC	31
3.3 Advantages and disadvantages of ETC	32
4. THE DEVELOPMENT OF RFID SYSTEM	34
5 CONCLUSION	36
REFERENCES	37

PICTURES

Picture 1. The RFID system map (Chifang Hua, 2011)	9
Picture 2. The basic concept of application software	10
Picture 3. The structure of internal EPC (Zilong Liu,2014)	13
Picture 4.The structure of a complete EPC (Dongsheng Liu, 2014)	13
Picture 5.The EPC identification method	18
Picture 6.The structure of reader-writer	21
Picture 7. The work flow of EPC	26
Picture 8. An example of EPC winding	28

TABLES

Table 1.The main differences between Non-contact ID card and EPC	8
Table 2. The comparison between EPC and barcode	17
Table 3. The frequency band of some countries	24
Table 4. RFID frequency bands (Dipanlar, 2009)	25

List of Abbreviations (OR) Symbols

AIDC	Automatic identification and data capture
CMOS	Complementary Metal-Oxide-Semiconductor Transistor
COB	Chip on Board
DRAM	Dynamic Random Access Memory
ETC	Electronic Toll Collection
EPC	Electronic tag
GDSII	A commonly used format for the integrated circuit
IC	Integrated Circuit
IEC	International Electrotechnical Commission
ISO	International Standardization Organization
RFID	Radio Frequency Identification
SOC	System on Chip
UID	Unique Identification Number

1 INTRODUCTION

With the promotion of economic globalization, international trade, and the information networking, auto identification is more and more widely used in commercial distribution, physical distribution, postal service, transportation, medical treatment, public health, aviation, book collection software, electronic commerce, and e-government affairs.

Identification is a basic requirement for the human beings. Naming an object is the definition stage of identification; when we use something, we use our eyes, noses or any other complex, testing method to identify it. This is the procedure stage of identification. When the identification is finished, the conclusion is the result of the identification. With the development of the society, identification becomes more and more complex so it is more and more expensive to complete the identification, and even sometimes, the simple human identification cannot solve the problem.

Automatic Identification is an important improvement of the identification process. The Radio Frequency Identification (RFID) is a pattern of automatic identification. It is the wireless use of electromagnet fields to transfer data, for the purposes of automatically identifying and tracking tags attached to objects (Wikipedia, 2015).

2 RFID TECHNOLOGY SYSTEM

2.1 Basic Concept of RFID

RFID is a comprehensive technology which involves microelectronics, information technology, and communication.

RFID technology originated from the radar technology, but developed very slowly in its early stage. Since the 1990s, the rapid development of microelectronics technology has made RFID technology indispensable to our life at an incredible speed. Electronic tags using RFID technology have a small volume and a huge storage capacity. They can be re-used many times, and also support quick identification, long distance identification, mobile identification, multiple objects identification, location and long-term follow-up management. So RFID is widely used in public security, manufacturing management, logistics and supply chain management, and traffic management, military and so on. The RFID technology shows great development potential, and is considered as one of the information technologies with most prospects.

The most important advantage of RFID is non-contact identification as it can penetrate snow, fog, ice, paint, and dirt, can read the tag in bad weather when the code bar cannot be used, and the reading speed is really fast, in most cases less than 100 microseconds.

Conceptually, RFID is quite similar to barcoding scanning. In barcoding, an encoded barcode is attached onto a target object and an optical signal is used to transfer the object information from the magnetic bar to the specialized scanner. RFID uses the specialized RFID reader-writer and the specialized RFID barcode, and makes use of the frequency signal to transfer the information from

the RFID barcode to the RFID reader-writer. Structurally, RFID is a simple wireless system; it only contains two basic components, which are used to control, detect and track the target object.

To understand RFID better, it is important to introduce the following concepts:

Electronic Tag (EPC) is a tag which can be embedded into the target object and be identified through the frequency signal.

Reader-writer is a device which can read and write the information of EPC at a farther distance (such as 1m- 10m).

UHF-RFID is Radio Frequency Identification which uses ultra-high frequency.

The identification of non-contact Integrated Circuit (IC) card is also called RFID, but its operating principle, the content of technology, executive standard, manufacturing method or other field is other than the identification of EPC. The main difference between IC and RFID is illustrated in Table 1. At present, non-contact IC is widely used, in a passports or transport cards.

Table 1. The main differences between Non-contact ID card and EPC

	Frequency	Coupled Mode	Identification Distance
Non-contact ID card	$\leq 13.56\text{MHz}$	Inductance	Less than 20cm
EPC	860MHz-- 960MHz	Reflection of electromagnetic wave	More than 1m

2.2 The System Structure and operation principle of RFID

A RFID system's main components are the data carrier (the EPC), the RFID reader and the computer application (See Picture 1). The operating principle is that the RFID reader sends a radio signal. When the EPC comes into the range of the radio signal, the energy in the signal is used as power for the IC chip in the EPC. The IC chip analyses the received information and sends a return message. The answer is transferred to the RFID reader as radio signal reflectivity. Then the RFID reader analyses the answer and controls the communication with the EPC till it completes the reading of the EPC information. Finally, the RFID reader transfers the tag data read from the EPC to the computer.

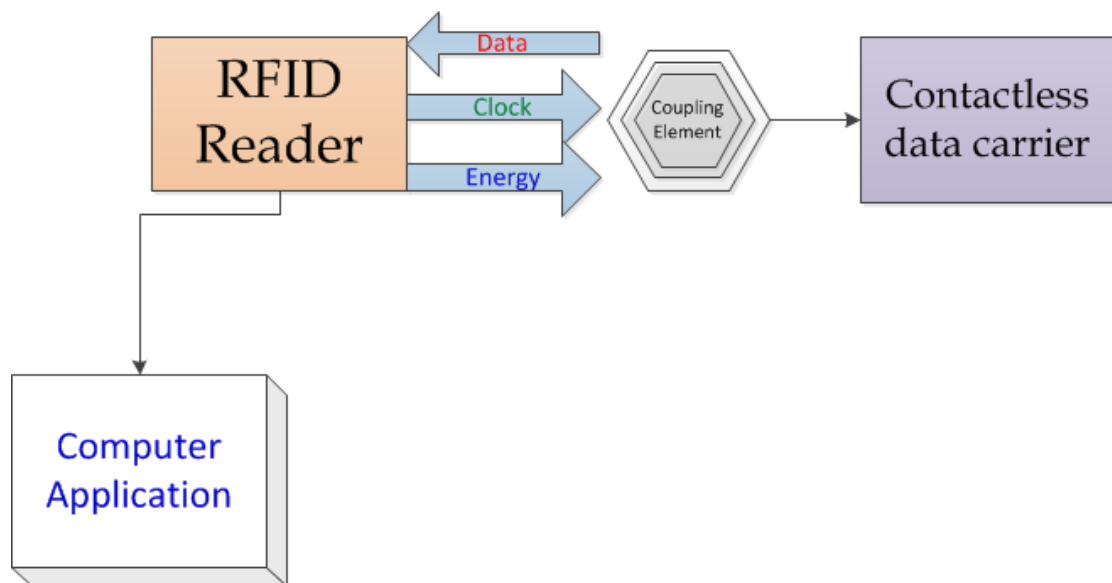

Picture 1. The RFID system map (Chifang Hua, 2011)

Some of the information stored in the EPC is written in when it is processed. This information includes the UID, the production information of the IC chip, the production information of the EPC and so on; Information can also be written in when the tag is used, e.g., the issue information of EPC, the information of the identified objects.

The RFID application software is closely related to the application area and its function includes the EPC data collection, data processing, data use and data security. Picture 2 illustrates how data collection is performed by the reader-writer. The safe data handling is carried out by the computer, which includes the data integration, database management, the encoding of the EPC and the communication. The data use includes information trace-back, data statistics and testing.

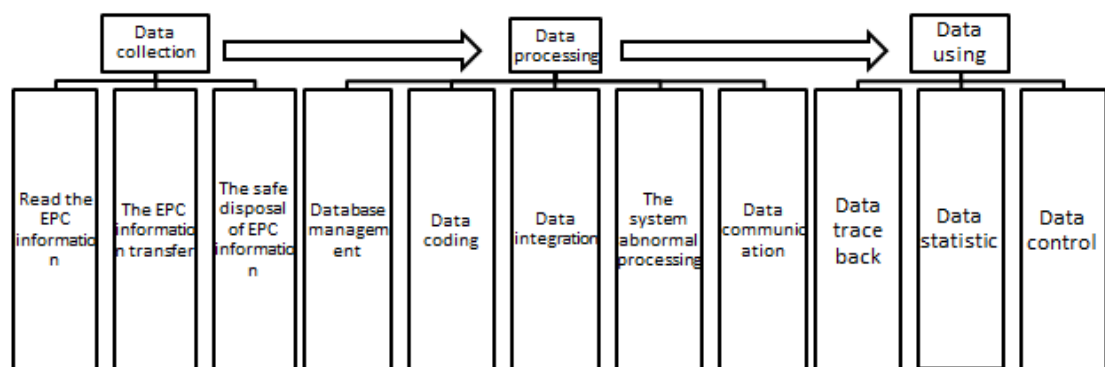

Picture 2. The basic concept of application software

The EPC can be attached on different objects, and record the information of corresponding objects. That means that the identification of the EPC is the identification of the objects and the distance of RFID is from 0 to 10 m or more.

2.2.1 The key technology of RFID

The RFID technology includes the basic technology, the industrial technology and the application technology.

The basic technology of RFID is foresight technology at international advanced level, and huge potential. This potential can be reflected in the numerous RFID research areas. Examples include research into ultra-low-power circuits using RFID tag chip, research into RFID tag chip's security algorithm and its application, research into reader-writer's kernel module, research into different application objects' RFID antenna, research into tag packaging equipment's key technology, research into RFID and other technologies' integration and fusion, RFID system checkout and authentication research, the research of IPV6- based RFID information system.

The industrial technology includes the design and production of chips, the design and production of antennas, the package technology and equipment of EPC, RFID tag integration, the design and production of reader-writer.

- The design and production of chips includes the design and production of low cost and low power RFID chip, the new storage technology which is suitable for the tag chip, anti-collision algorithm and the circuit realized technology, chip security technology, the integration technology of tag chip and sensor.
- The design and production of antenna includes the matching technology of tag antenna, different application objects' RFID antenna structuring technology, the distributing technology of antennas with multiple tags, reader-writer scans the antenna array technology, development of simulation software of RFID tag's antenna and so on.

- RFID tag packaging technology and equipment includes developing packaging technology with low temperature and hot pressure, the self-diagnosis and repair of the equipment, the online testing technology and so on.
- The EPC integration includes study of the matching technology between the chip, antenna and the special material medium, the consistency, anti-interference and security of EPC.
- The design of reader-writer includes the anti-collision technology, the anti-interference technology, the development of reader-writer, the development of ultra-high radio frequency module, the security certificate technology.

The main technological part of RFID application technology includes: the structure of RFID application system, system integration and middleware, public service system, testing system.

- The structure of RFID application system includes the hardware and data interface technology and service in the RFID application system, coordinates the relationship between different parts of the system, and provides the system integration guide to the customers.
- The RFID system integration and data management include the integration technology between RFID and wireless communication, sensor network, information security and industry control, RFID system middleware technology and so on.
- The RFID public service system supplies the certificate, register, code management, provides retrieve and trace service, and ensures the validity and security of the system.

2.2.2 The EPC

The EPC is also called the RFID tag. The tag can be attached on the surface of the products or inside the products. The EPC's main components are the micro antenna and the IC chip. Picture 3 shows the structure of EPC antenna and chip and Picture 4 shows the structure of a complete EPC.

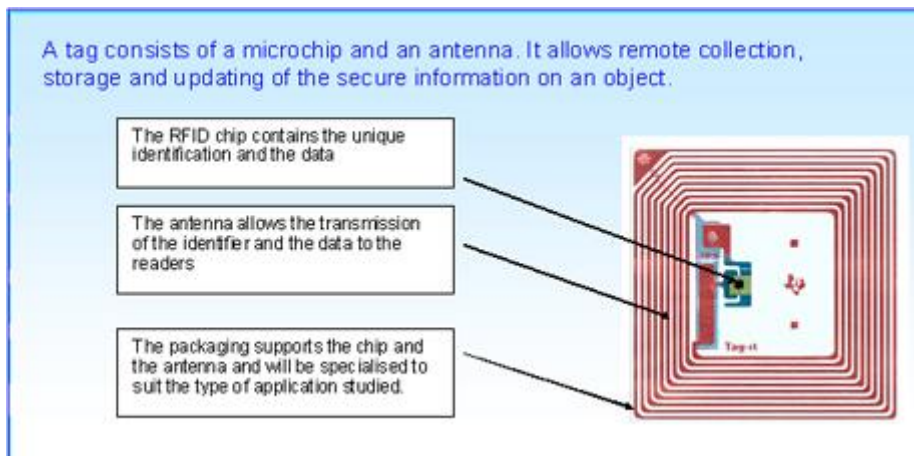

Picture 3. The structure of internal EPC (Zilong Liu,2014)

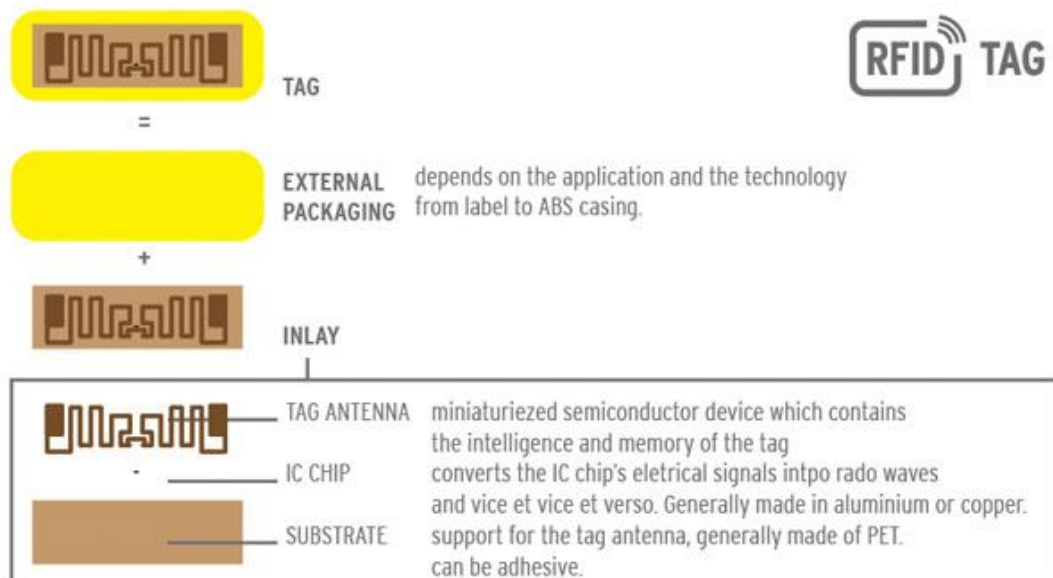

Picture 4. The structure of a complete EPC (Dongsheng Liu, 2014)

The EPC is a kind of dedicated integrated circuit which has been especially packaged. The micro-antenna can be seen as the frame of the integrated circuit. The chip's paste, alignment and bonding on the micro-antenna is similar to the frames. The covering layer of the tag is similar to the plastic package of the integrated circuit.

Other components, such as the micro-battery or the capacitor are only implanted in the tag when needed. In the early times, a capacitor could be added into the non-touch IC card to adjust the input impedance of the antenna. For an active tag, a micro-battery is needed. For an integrated circuit package, it is also common to add some components, for example, a low cost RAM storage and a micro-battery together, to make it to be a non-volatile memory.

The EPC can be classified according to the following categories:

- According to the power supply mode

The active tag is the tag with micro-battery inside. The tag itself has power, so it can send the signal to the reader-writer to be identified; some active tags can send the signal after receiving the signal from the reader-writer. This kind of tag is called semi-active tag. The acting distance of active tag is farther, normally can be tens of meters. The disadvantages of semi-active tags are their high cost and the fact that they are, hard to be miniaturize. In addition, the attenuation of battery may influence the distance of identification, and the life is short and so on.

The active tag is the tag without a micro-battery inside. This kind of tag should go into the working range of the reader-writer, and then transfer

the signal sent by the reader-writer to power to power-up for the IC chip. To get enough energy, the distance of identification cannot be too far away. Normally, the distance should be 1 to 10 m. In addition, the passive tag asks the IC chip if it needs to be low-powered, there should be enough capacitance to storage electric energy inside the tag. With the development of the passive tag, the area of the IC chip is becoming smaller and smaller, the work speed is becoming faster and faster, and the power is lower and lower. This means reduction of the cost and the improvement of performance. So the passive tag is the main development trend.

- According to the packaging shape

As a code: This kind of tag is a kind of flexible label just like the barcode, and can be attached on the surface of different objects.

As a card: This kind of tag is just like the non-contact card or the credit card. Actually, the non-contact card is a kind of RFID. Its frequency is 13.56 MHz, the identification distance is under 20 cm, and it communicates through the coupled mode. This kind of EPC is not included in the tag series. It is easy to take along and can also be used for longer distance identification.

As a badge: The outline of this kind of EPC is a badge or a pendant. It is suitable for implanting the battery, and easy to take along. It can also be used for the longer distance identification.

- According to the storage type

The read-only tag: This is the tag which can only read the information.

The data is written in the tag when it is been produced, and cannot be

modified. The data in the tag primarily contains the unique identification (UID) of the product. This kind of EPC cannot be reused.

The read-writer tag: This kind of tag can be written any time. The information in this kind of storage can be modified, so it can record the real-time information during its use. It is convenient to be traced. This kind of tag can be reused for many times.

Nowadays, most IC chips of the EPC have both the above functions, which means that some part of the storage is read only, while some parts of the storage can be programmed.

Regardless of which kind of EPC is used, the key device is the IC chip. The main circuit of IC chip includes a RFID interface circuit, a modem circuit, a microcontroller, program memory, a nonvolatile memory, a power circuit, a test circuit, an encrypted circuit and so on. However this does not mean that the IC chip should include all the above circuits. Actually, in different systems, the chip requirements are different and the types of the IC chip are also different.

During the manufacture and circulation of the products, the barcode's appearance is a revolutionary identification system and its wide range of applications is certain. The barcode is constituted of different degree strips (black) and different degree spaces (white), and the different strips correspond to different information. The reflectivity of strips and spaces is different, so the barcode reader can read the information of barcode, which is the information of the products. Then, it transfers the data to the computer to be processed or for other operation. The EPC's application method is similar to barcode's, but the basic theory and performance is quite different, the comparison between them two can be seen in Table 2.

Table 2. The comparison between EPC and barcode

	EPC	Barcode
Label Composition	IC chip+ mini-antenna+ paper carrier	Paper carrier
Data storage method	In the IC chip	The strips in black and white check on the carrier
Data storage ability	128bit—64Kb	400bit (one – dimensional)
Identification method	RFID	Different light reflectivity identification
Identification distance	0—tens of meters	Less than 20cm
Number of identification	Hundreds	1
Identification environment	Can work in harsh environment	Without pollution
Data modification	Can be modified or rewritten	Cannot be modified
Data security	Can be encrypted	Plain code
Replicability	Hard	Easy
Cost	Relatively high	Low

From Table 2 we can see that the barcode only can be identified at a close range, the ability of data storage is small, it cannot be rewritten, can be easily counterfeited, and the traceability is poor. Therefore, it cannot satisfy the requirements in many application scenarios. The EPC can be identified at a long distance, its ability of data storage is large, it also can be written in any time, the manufacturing and circulation information can be easily recorded, and finally it can be the quickly identified and traced.

The whole EPC system includes: the EPC, the reader-writer, and data processing system. In the physical application, usually many reader-writers constitute an array. For example, there are tall gates in supermarkets. In each gate, there is a reader-writer and the data read by every gate is gathered to the host computer to form a simple identification net. This process is shown in Picture 6.

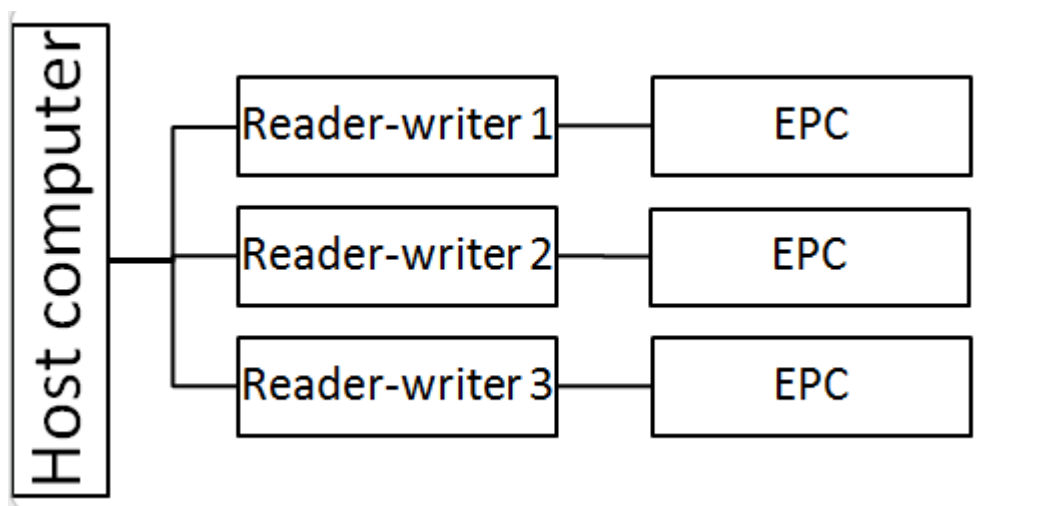

Picture 5.The EPC identification method

The design of the EPC identification system should take the following into consideration.

The identification distance: In the 860MHz—960MHz frequency band, the identification distance can reach 1 m—10 m in general. There is little difference between different products but the cost is also different. The requirement of the identification distance should be redundancy, but it cannot be too much, or the cost and technical impediment will increase. The identification distance of EPC determines the executed solution of the whole RFID system. For example, if the identification distance is about 3 m, the passive tag is enough; if the identification distance is more than 30m, the active tag should be chosen.

Working frequency: ISO/IEC 18000-6 defines the frequency range from 860MHz to 960MHz. Different countries use different frequency bands, For example, the frequency band for the United States is 902MHz—928MHz, the bandwidth is 26MHz; there are two frequency bands for China, they are 840MHz—845MHz and 920MHz—925MHz and the total bandwidth is 10MHz. If we choose a reader-writer which can be used for all the frequency bands, the cost will be high, the technical impediment, system stability and reliability will be influenced at the same time. So the choice of the working frequency of RFID system should be based on the application objects.

The requirement of anti-collision: For some RFID systems, the possibility of more than one EPC in the RF field is little, there is no requirement for anti-collision; for some RFID systems, there may be hundreds of EPCs in the RF field. This requires high ability of processing the anti-collision, and this should be fast. For example, when adding the EPC to the products on the production line, they can only go into the RF field one by one, so the anti-collision is not needed; but for a toll collection system in the supermarket, there may be many products in a shopping cart, so the requirement of anti-collision is needed. Differences the anti-collision ability may influence the system cost.

The requirement of data security: For the security of data storage, the data back-up should be taken into consideration. To ensure the privacy of data, the data should be encrypted during the transmission. The wireless communication is easier to be stolen during the procedure, so in some RFID application areas, there should be encryption measures.

The requirement of data processing: In the logistics RFID system, the data needed to be processed is large every day; but in the parking lot management system, the requirement of data processing is not large. So the assessment of the requirements for the system data processing is very important during the design

2.2.3 The reader-writer

In the RFID system, the reader-writer is the basic device. In many systems, only reading the data is needed. This kind of read-only device is called the reader. The reader is almost the same as the reader-writer except it cannot write data to the tag.

The basic structure of the reader-writer is shown in Picture 5. It includes: a micro-controller, data memory, an interface circuit, a frequency generating unit, a modem circuit, a signal-amplifier, and an antenna circuit and so on.

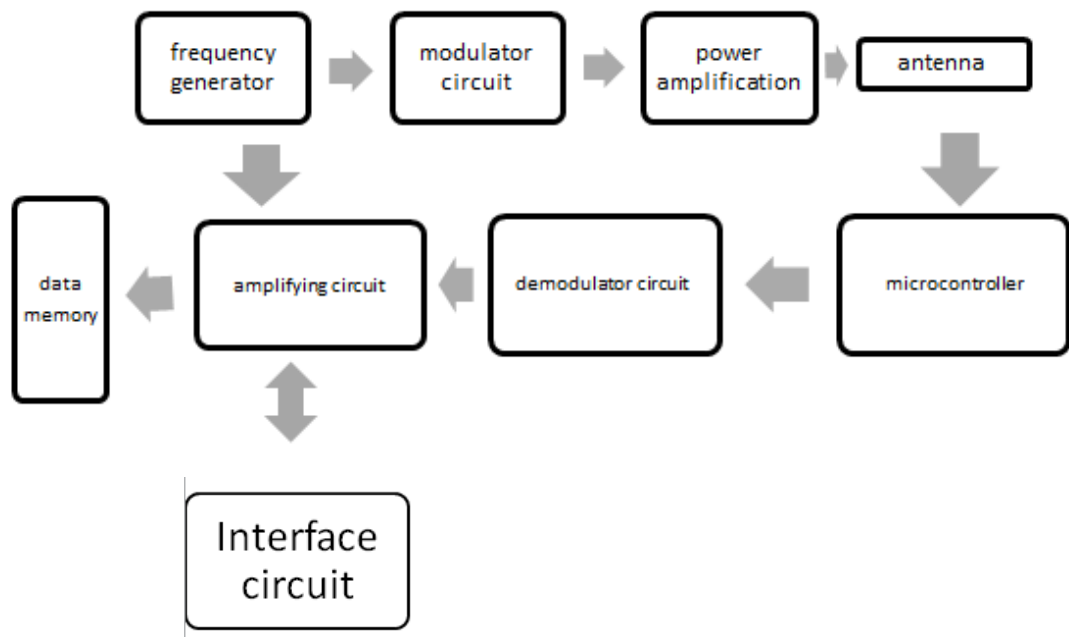

Picture 6. The structure of reader-writer

The reader-writer controls the communication with the tag, which means that the whole identification is under the reader-writer's control. The reader-writer sends the wireless signal constantly when it is in working mode; if the tag goes into the RF field (the identification range) of reader-writer, it will reflect the answer signal to the reader-writer; the communication tunnel with the tag will be built after receiving the answer signal, and then it completes the reading and writing of the tag through the commands. The information read by the reader-writer will be stored temporarily or transferred immediately.

The reader-writer performs the following functions:

- It builds the wireless communication with the tag, which includes the encoding and decoding, the modulation and demodulation of the data, and completes the identification.
- It communicates with the host computer through the standard interface.

- If there are many tags going into the RF field at the same time, it should distinguish them and read and write them one by one.
- It verifies the data
- It stores the data
- It has an embedded control system which can be programmed
- It has some other functions, such as display, voice and so on

To realize the functions of reader-writer, a functional software is needed to a great extent. It can be used to: control the communication with the tag, complete the data exchange with the host computer, and perform data encoding, decoding and encryption and so on.

Normally there are two types of reader-writer:

The *omnipotence reader-writer* is a kind of reader-writer that can be used at different frequencies, coding methods, anti-collision algorithms and modulation methods. It can reach the standard of the tag applied through the switch or program to complete the read and write of the information or it can read and write to different standards' tags.

The *dedicated reader-writer* is a kind of reader-writer which is only focused on a standard of tag and it can only operate on the tags which meet the standard; the frequency of the reader-writer can be adjusted to meet the different requirements of different countries. The cost of this kind reader-writer is relatively low and its reliability is relatively high. The application of dedicated reader-writer is more than that of the omnipotence reader-writer.

The whole reader-writer can be gathered on an IC chip to constitute a system on chip (SOC) which is based on micro-electronics technology. IC chip

manufacturers implant the control software into SOC, and then control the software according to the requirements to adjust different EPCs. The SOC chip can reduce the cost of the reader-writer and miniaturization. This will lead to revolutionary developments of RFID applications. At the same time, the microminiaturization of the reader-writer should influence the microminiaturization technology of antenna.

2.3 The Frequency Choice

The radio frequency is a limited resource. Radio frequencies are widely used in different fields and new applications have more and more requirements on this limited spectrum resource. A scientific frequency plan is the basis of making efficient, reasonable use of the spectrum resource.

Every country manages the radio spectrum resource strictly and differently. There is not a common frequency and bandwidth for RFID. For example, ISO/IEC 18000-6 have just given a frequency range from 860 MHz to 960 MHz, the real application frequency of the United States is 902 MHz—928 MHz (the bandwidth is 26 MHz). The frequency may influence the design of reader-writer especially the design of the antenna.

If the RFID products are applied in different countries, the frequency should meet the requirements of the local radio frequency. Some of the countries' frequency bands are shown in Table 3, which includes the limit of the reader-writer reflecting power.

Table 3. The frequency band of some countries

Country	Frequency band	Effective radiated power(ERP)
USA	902MHz—928MHz	4W
European Union	868MHz—870MHz	500mW
Australia	918MHz—926MHz	1W
Hong Kong China	865MHz—868MHz	2W
	920MHz—925MHz	4W
Japan	952MHz—954MHz	-
Korea	908.5MHz—914MHz	-
Singapore	866MHz—869MHz	500mW
	923MHz—925MHz	2W
China	840MHz—845MHz	2W
	920MHz—925MHz	100mW

Table 4 shows the frequency which can be used for RFID. The LF 134 kHz and HF 13.56MHz have been widely used in the non-contact IC cards such as transportation cards, ID cards and so on.

Table 4. RFID frequency bands (Dipanlar, 2009)

Band	Regulations	Range	Data speed	Remarks
120—150 kHz	Unregulated	10 cm	Low	Animal identification, factory data collection
13.56MHz(HF)	ISM band worldwide	10 cm—1m	Low to moderate	Smart cards, Non fully ISO compatible memory cards, Microprocessor ISO compatible cards
433MHz(UHF)	Short Range Devices	1–100 m	Moderate	Defense applications, with active tags
865-868 MHz (Europe) 902-928 MHz (North America) UHF	ISM band	1–12 m	Moderate to high	EAN, various standards
2450-5800 MHz (microwave)	ISM band	1–2 m	High	802.11 WLAN, Bluetooth standards
3.1–10 GHz (microwave)	Ultra wide band	to 200 m	High	requires semi-active or active tags

2.4 RFID industry chain

This section introduces how EPCs and the reader-writers are manufactured.

2.4.1 The production process of EPC

The basic devices of EPC are: a tag antenna, an IC chip and the packaging material. Picture 8 shows the work flow of producing the EPC which includes: the design and production of EPC, the design and production of antenna, packaging design, and the production of packaging material, the packaging, the test and initialization of EPC.

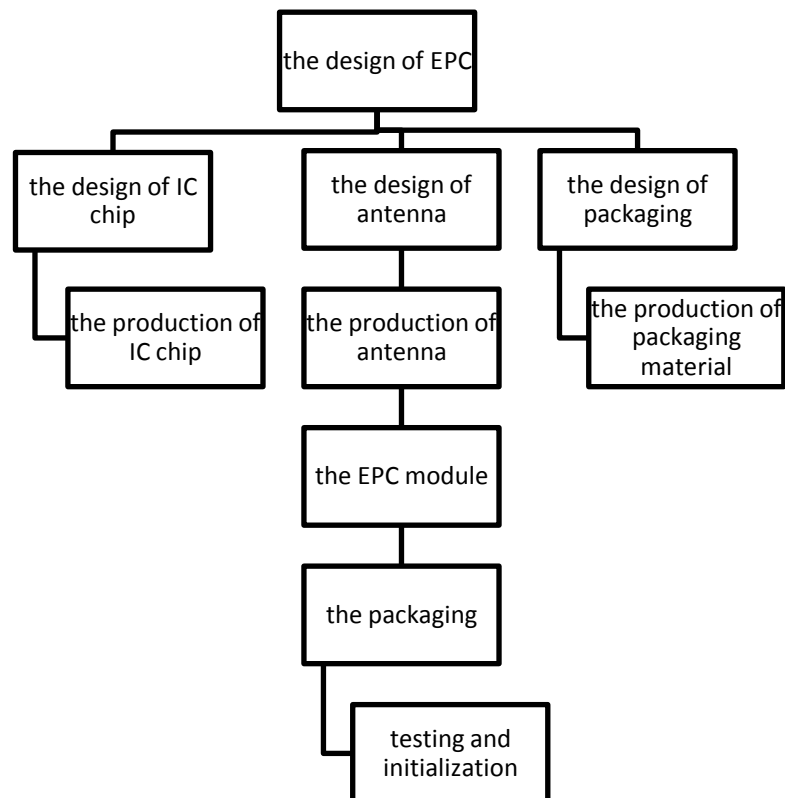

Picture 7. The work flow of EPC

As seen from the integrated circuit, the production of EPC is a special packaging method of the integrated circuit. The antenna is just like the packaging strip of the integrated circuit. The IC chip is installed on the antenna strip, and then the

outer cover is added. This procedure is just like the soft packaging of the integrated circuit, or chip on board (COB).

The design and production of ECP chip includes the following processes:

The design of IC chip: The IC chip used in the RFID system can be classified into two types, the first one is used for different types for tags; the second one is the IC chip for the reader-writer. The layout is designed as the integrated circuit layout data, and the IC chip submits the data as GDSII to the integrated circuit manufacturer to complete the whole product process. GDSII is a commonly used format of the integrated circuit domain.

The production of the integrated wafer: The production of the integrated circuit is completed on the production line. This means on the wafer, which is a thin slice of semiconductor material, such as a crystalline silicon, used in electronics for the fabrication of integrated circuits. Using the IC domain data provided by the customer, the manufacturer can complete the production, medial testing, mark the disqualification chips, and finally output the wafer with IC chips.

The subsequent processing of wafer: The subsequent processing of the wafer is completed by the packaging company and includes the slivering of the wafer, installing the IC chip on the strips, packaging the IC chip into the dedicated packing box.

The design of antenna should be completed by the manufacturing company. The antenna should be small, low cost, and highly adaptable. There are two main methods of antenna's production:

The etching method: This method is similar to the production of the printed circuit board. The manufacturer smears the photo-sensitive resist on the antenna's material which is copper foil or aluminum foil, and then exposes and

corrodes the material according to the shape of the antenna to form the final antenna shape which is similar to the flexible printed circuit board.

Silk-screen printing: This is printing a tier of ink-conducting material on the substrate according to the shape of antenna to form the needed antenna shape.

In industrial production, generally antennas are produced in the form of winding, and have different standards. There may be hundreds to thousands of antennas. The production of antenna requires dedicated equipment and source material.

Through the dedicated EPC production equipment, the manufacturing equipment bonds the tag chips onto the antenna windings, and pastes the covering layer outside and then covers the print media which can be printed on one side, smears with glue and adds the covering layer on the other side, finally forming the EPC winding. Picture 9 illustrates an example of EPC winding.



Picture 8. An example of EPC winding

2.4.2 The reader-writer machines and tools

The machines and tools used in the reader-writer production include the reader-writer/the reader, the tag printing programming equipment, and the development tools. The reader can only read the information of the EPC, generally used in the read only instances; the reader-writer can read and write the information to the EPC, generally used for the initialization and individuation of the EPC or in the instances when it is necessary to modify the information in the tag; the tag printing programming equipment usually contains the functions of the reader-writer, and prints the visual information on the surface of the EPC. The tag printing programming equipment used in the production line can paste the tag on the products automatically.

The development tool includes the emulation board, multiple antennas multiplexer, development software, standard function library, anti-collision algorithm module, data encryption algorithm module, demonstration software and so on.

3 APPLICATIONS OF RFID

This chapter introduces the application range of RFID, and the ETC system.

3.1 The application range of RFID

The range of RFID is wide in the different areas of our life.

Public security: RFID can increase the management ability of the social security. This includes: medicine and health safety, the food safety, hazardous article management, anti-fake safety, electronic ID card, entrance guard management and so on.

The control and management of production: To improve the informatization level of manufacturing industry, the manufacturing company applies RFID technology in the source material supply, in production management, in production process control, and in precision manufacturing. The application of RFID technology in these areas increases production and management efficiency. RFID applications in production management and control include automobile manufacture, household appliances manufacture and so on.

The logistics and the supply chain management: Logistics and supply chain companies use RFID in the production to trace cargoes and share the information with each other. The use of RFID technology may change the traditional supply chain management method thoroughly, and improve the enterprise operational efficiency greatly. The application areas include: the

storage management, the logistics distribution, the container transportation and so on.

The import and export management: Applying RFID technology in this area may achieve the tracing and location of the import and export cargoes, therefore increasing the efficiency of custom control.

The transportation management: In this field RFID can identify the high speed vehicles, can locate and collect statistics of the transportation components, such as engines, and can easily manage and control vehicles. The applications include: ETC, vehicle management, the facility management and so on.

3.2 ETC

The electronic toll collection (ETC) system uses RFID technology to complete the wireless data communication between vehicle and toll station, and then deduct the toll through the data exchange between the vehicle and toll collection network.

The key technology of the ETC system is the RFID technology. The ETC system is mainly composed of the ETC toll lane, the toll management system, the ETC management center, a professional bank, a lane controller display, an automatic machine, and a vehicle detector and a transmission network.

Through this system, the car owner just needs to install the electric tag on the window of the car and pay a deposit in advance. The cars can go through the toll station without a manned toll station or stopping the car and the fee will be deducted automatically. This kind of system lasts less than 3 seconds per car and the amount of traffic capacity the ETC system can handle is 5 to 10 times more than the manned toll station.

The ETC system is highly suitable for highways, busy bridges and tunnels. Unlike traditional manned toll stations, the ETC technology uses IC cards as data carrier. A computer can read the vehicle's information from the IC card information (such as vehicle type, the owner, license plate number, etc.), and deduct the road toll based on the information.

3.3 Advantages and disadvantages of ETC

The advantages of ETC are listed below:

Firstly, ETC can drastically improve the time the toll station takes to handle toll collection; the time for per vehicle toll collection is only 3 seconds with ETC, compared to 30 seconds in a traditional toll station. Then, the vehicle does not need to stop when going through the toll station, so the fuel consumption can be reduced. Thirdly, the cost is reduced because in a manned toll station, there should be a person responsible for the toll collection per gallery, and the cost for toll collection personnel is quite high every year. Lastly, ETC can reduce accidents. During the peak traffic, the vehicles should be in line at the manned station so the vehicles going into a gallery may crash into each other. On the contrary, with the ETC system, the vehicles do not need to stop, thus the number of accidents will be reduced.

The disadvantages of ETC are listed below:

Firstly, the vehicles may not be able to go through the station or go through the station without paying the toll. Secondly, the weather may influence the devices since the devices are in an outdoor environment, they may be easily damaged. Lastly, it is slightly difficult to manage the tolls for all the vehicles because not all the vehicles have an EPC and not all the roads use the ETC system. In such

cases, a manned station is still needed for the vehicles which do not have an EPC.

4. THE DEVELOPMENT OF RFID SYSTEM

The history of RFID can be dated back to 1950s, it was originated from the concept of radar and the communication between man-made earth satellite and earth station. However, it did not develop to the EPC which is similar to the barcode until recently. Its recent development to the EPC is the result of the progress of micro-electronics technology.

In the beginning of 21st century, the progress of micro-electronics technology made it possible to apply the CMOS technology on the base of monocrystalline silicon which can produce high working frequency, low power consumption and low cost IC chip. The progress of the micro-electronics technology solves the problem of how to make the EPC as small as possible, and there are more and more types of EPC that have appeared and been applied in different fields.

Some of the greatest retail chains in the worlds have also discovered the advantages of EPC, that is, the improvement of the transparency of logistics and the working efficiency, and they have come up with their own RFID development projects one after another. Some retail chains even require their suppliers to attach EPCs on 70% of the products at a given time. This kind of requirements reflects the urgency of using the EPC in logistics.

To occupy a leading position in the RFID market, some developed countries formulated the standard of RFID, such as the EPC Global in the U.S.A, the UID of Japan and so on. ISO and IEC also constitute the international standard of RFID ISO/IEC 18000-6.

The cost of EPC is far more expensive than that of the barcode and this is one of the main reasons of its restricted development. However, with the development

of micro-electronics technology and miniature antenna production technology, the market of EPC which can expand to logistics and manufacture management, the cost will also be decreased.

5 CONCLUSION

This thesis mainly introduced the RFID technology and its applications and the applications of the ETC system. The ETC system is widely used worldwide, but there are still some problems that need to be solved, and some drawbacks that need to be rectified. The manual toll station cannot meet the requirements of modern highway compared to the traditional collection method. The ETC system, however, will offer great benefits in the near future and it will replace the traditional collection method. Nevertheless, research and improvement should mainly focus on perfecting the ETC system.

Concerning the development trend of RFID technology, the micro-electronic technology is a key of EPC development. Because of the development of the micro-electronic technology, the CMOS technology can be used to complete the production of high frequency IC chip. This may reduce the costs and enable EPC to gradually replace barcodes.

In the recent years, the RFID technology has been popularized rapidly with the development of micro-electronics technology, and has become an important branch of the information technology.

In future, the RFID system is highly likely to develop into a huge internet of things, consisting of the networked reader-writers and moving reader-writers. The identification, position, trace, monitor, and control of objects will be achieved automatically and timely. Building an RFID system structure based on the next generation networking, will be the future development of the ICT industry.

REFERENCES

Chi-Fang Huang. 2011 Introduction in Cornel Turcu, Low-Cost Solution for RFID Tags in Terms of Design and Manufacture. CC BY-NC-SA 3.0 License.

Guangwei Liu, Luhong Mao. 2014. Locatable-Body Temperature Monitoring Based on Semi-Active UHF RFID Tags. Available at: <http://www.mdpi.com/1424-8220/14/4/5952/html> Accessed: 27 May 2015.

Li, Quansheng, Liu, Zhongli & Wu Lijiang. 2010. Ultra High Frequency Identification Technology and Application, Beijing:National Defence Industry Press.

Nan, Wu & Xiangdong, Li. 2011. Introduction in RFID Applications in Cyber-Physical System. CC BY-NC-SA 3.0 License

Sen, Dipankar; Sen, Prosenjit & Das, Anand M. (2009), RFID for Energy and Utility Industries. PennWell, ISBN 978-1-59370-105-5

Wikipedia, Radio-frequency identification

Available at: http://en.wikipedia.org/wiki/Radio-frequency_identification Accessed: 29 May 2015.

Zi, Bo. 2013. Automatic Technologies. Available at: <http://www.zatcn.com/cn/Productview.asp?id=74> Accessed: 7 June 2015

Zilong, Liu & Dongsheng, Liu. 2014. Design of an Elliptic Curve Cryptography Processor for RFID Tag Chips. Available at <http://www.mdpi.com/1424-8220/14/10/17883> Accessed: 10 June 2015