

ANALYSING A SAFETY PLC RAILWAY LEVEL
CROSSING SYSTEM FOR THE DESIGN OF AN
EDUCATIONAL DEVICE

Rautatieto Oy

Diedericks André

Thesis

Electrical and Automation Engineering
Bachelor of Engineering (UAS)

2023

Electrical and Automation Engineering
Bachelor of Engineering (UAS)

Author(s)	André Diedericks	Year	2023
Supervisor(s)	Ari Afflekt, M.Sc		
Commissioned by	Rautatiето Oy		
Title	Analysing a safety PLC railway level crossing system for the design of an educational device		
Number of pages	65 + 6		

The aim of the thesis was to develop and design a device, to induce faults, that can be integrated into a safety PLC based Finnish railway level crossing, for training and educational purposes. The thesis was commissioned by Rautatiето Oy.

The goal of the thesis was reached with the extensive use of literature and information from the Finnish Transport Infrastructure Agency on signalling system design as well as safety standards for level crossing. In addition, in-depth analyses of Finnish railway level crossings were made including their technical drawings, as well as individual instructions on maintenance and commissions.

As a result of the work, an extensive knowledge base was developed, with instructions, technical drawings, and educational material for the main goal of the thesis, a device that induces faults in a railway level crossing. The device was also designed to have the ability to be adapted to fit the skill level of technicians and environment it is used in.

Keywords

level crossings, programmable logic controllers, engineering design, signalling systems.

Sähkö- ja automaatiotekniikka
Insinööri (AMK)

Tekijä(t)	André Diedericks	Vuosi	2023
Ohjaaja(t)	Ari Afflekt, FM		
Toimeksiantaja	Rautatieto Oy		
Työn nimi	Rautatien PLC-tasoristeysjärjestelmäänalyysi koulutuslaitteen suunnittelua varten		
Sivumäärä	65 + 6		

Opinnäytetyön tavoitteena oli kehittää ja suunnitella PLC-pohjaiseen Suomen tasoristeykseen integroitava vikoja aiheuttava turvalaite. Laitteen on tarkoitus toimia apuna koulutuksissa. Opinnäytetyön teetti Rautatieto Oy.

Opinnäytetyössä käytettiin aineistona laajaa käyttökirjallisuutta ja Liikenneviraston tietoja opastinjärjestelmien suunnittelusta ja tasoristeysten turvallisuusstandardeista. Lisäksi tehtiin perusteellinen selvitys Suomen rautateiden tasoristeyksistä ja niiden teknisistä piirustuksista sekä yksittäisistä huolto- ja toimeksianto-ohjeista.

Työn tulokseksi saatiin laaja tietokanta, jossa oli ohjeita, teknisiä piirustuksia ja opetusmateriaaleja. Lisäksi tuloksena saatiin opinnäytetyön päätavoite, rautatien tasoristeyksessä vikoja aiheuttava laite. Laite on myös suunniteltu mukautettavaksi teknikkojen taitotasoon tai käyttöympäristöön sopivaksi.

Avainsanat

tasoristeykset, ohjelmoitavat logiikat, tekninen suunnittelu, turvalaitteet

CONTENTS

1	INTRODUCTION	9
2	HISTORY AND CURRENT STATUS OF THE CONTRACTOR	10
2.1	Rautatieto Oy	10
2.2	Sundström Ab, Oy Entreprenad	11
3	LEVEL CROSSING	12
3.1	Overview.....	12
3.1.1	Un-guarded level crossing.....	12
3.1.2	Guarded level crossing.....	13
3.1.3	Safety	14
3.1.4	Accidents.....	15
3.2	Standards	17
4	SAFETY PLC.....	21
4.1	Overview.....	21
4.2	PLUTO D45	21
4.3	HMI	23
4.4	Safety.....	23
5	AXLE COUNTERS	25
6	OBJECTIVE OF THE THESIS.....	27
6.1	Primary objective – Part 1	27
6.2	Primary objective – Part 2.....	27
6.3	Secondary objective	27
7	METHODOLOGICAL IMPLEMENTATION	28
7.1	Development method.....	28
7.2	Development stages	28
7.3	Results and reporting.....	29
8	LEVEL CROSSING ANALYSES.....	30
8.1	Functions and operating modes.....	30
8.1.1	Track section	30
8.1.2	Basic state.....	30
8.1.3	Alarm state	31







8.1.4	Automatic operation	32
8.1.5	Manual operation.....	32
8.2	Configuration and components	33
8.2.1	Road signals	33
8.2.2	Gantry system	33
8.2.3	Alarm Bells	36
8.2.4	Buttons and switches	36
8.2.5	Equipment room.....	37
8.2.6	Automation	38
8.2.7	Track vacancy monitoring	39
8.2.8	Level crossing signal.....	40
8.3	Level crossing analyses - Faults.....	40
8.3.1	Critical faults.....	40
8.3.2	Non-Critical faults	42
9	DESIGNING A FAULT INDUCING DEVICE	43
9.1	Design principals	43
9.2	Fault finding principles.	44
9.3	Fault inducing circuit.	45
9.3.1	Design of the circuit.....	45
9.3.2	Restrictions of the device	48
9.4	Physical device	49
9.5	Implementation of an HMI Panel.....	51
9.6	Challenges during the design phase.....	54
10	EFFECTIVENESS OF TRAINING	56
10.1	Field test.....	56
10.2	Effective education process and the impact of the environment in which it is used.	57
10.3	The impact of specification on the educational material.	58
10.4	Challenges during the data collection phase.	58
11	FURTHER DEVELOPMENT.....	60
12	DISCUSSION	61
12.1	Review of results	61
12.2	Examination of reliability.....	61

12.3	Discussion on learning process	62
REFERENCES	63
APPENDICES	65

SYMBOLS AND ABBREVIATIONS USED

CEN	European Committee for Standardization
CENELEC	European Committee for Electrotechnical Standardization
HMI	Human machine interface
ISA	Independent Safety Assessment
PLC	Programmable Logic Controller
RATO	Technical guidelines by the Finnish Transport Agency (Ratatekniset ohjeet)
TFFR	Tolerable Functional Failure Rate
THR	Tolerable hazard rate

RELAY ABBREVIATIONS

AJV	Undervoltage fault
MV	Ground fault
T*	Signal
Va	Colourless signal light
Vpu	Left Red signal light.
Opu	Right Red signal light
A	Barrier Lower limit 0°
YA	Barrier Middle limit 60°
Y	Barrier Upper limit 90°
Tpvar	Barrier supervision
R*	Track signal
V00*	Switch
Kr	Critical fault
Ei Kr	Non-critical fault
V	Fault
	Normally closed contact
	Normally open contact
	Relay contact (normally open circuit)
	Relay contact (normally closed circuit)
	Relay coil (normally open circuit)
	Relay coil (normally closed circuit)

1 INTRODUCTION

At the end of 2021, there were approximately 2600 active railway crossings in use on the Finnish railway network and an abundance of level crossings on private railway networks. At a rate of 20-30 railway level crossings being decommissioned on a yearly basis, the need for trained signalling system technicians that can carry out repairs and respond to faults, will remain high for years to come. (Finnish Transport Infrastructure Agency 2023a)

The aim of this thesis is to address the training of the signalling system technicians in question. This will be done by analysing different elements of a Finnish railway level crossing and in turn develop a resource to assist in the training of signalling system technicians. The results should be a resource that can introduce the concept of level crossings to new technicians, and in addition advancing the training of more experienced technicians. The goal is to improve safety in the workplace and minimize on-site training that could lead to the organisations involved being fined or give rise to hazardous situations.

With a variety of automatic level crossing systems currently in use in the Finnish railway network, such as relay-based level crossing systems, Pluto systems, Siemens S5 PLC systems and HIMatrix level crossing systems, the main principal for these systems remain the same. Faults are standardised in accordance with the Finnish Transport Agency's technical guidelines "RATO 6", signals, and barriers/gantries work on the same principals over all the current level crossing systems in the Finnish railway network.

Taking the standardisation of fault into account, this thesis can focus on analysing a single level crossing system as a basis for training. The thesis will focus on a ABB Pluto D45 programmable logic controller in combination with Frauscher axel detection devices.

2 HISTORY AND CURRENT STATUS OF THE CONTRACTOR

2.1 Rautatieto Oy

Founded by Arto Nivala, Rautatieto Oy has been a growing organisation in Oulu, Finland since 2011. The company specializes in the design, construction, and maintenance of Finnish railway automation, electrical, and signalling systems.

Since 2018 Rautatieto has expanded their business model to include the construction and maintenance of high-voltage railway lines, by purchasing Ratayhtiö and simultaneously releasing their first physical product, a track-fault locating device "TrackTester". With further expansion occurring in 2021 with the purchase of Opto- Liitos Oy, that specialises in the design, construction, and maintenance of optical fibre network systems. With these expansions it broadened the scope of projects, inside and outside of the railway industry that Rautatieto could bid on, creating a stronger foundation for the growth of the company. (Rautatieto 2023)

With consistent growth since 2018, In the last fiscal year, 2021, Rautatieto Oy had approximately 35 employees and made 3 998 000€ in turnover and its profit was 55 000€, compared to the previous year's profit of 600 000€. This change in profit reflects the purchase of Opto- Liitos Oy. (Kauppalehti 2023a)

With the expansion of Rautatieto, with offices in four cities over Finland, 50 employees and a turnover of 6,2 million euros at the end of 2022, Rautatieto was purchased by Sundström Oy. This purchase was made to strengthen the position of both companies in the railway industry. Rautatieto still functions as its own enterprise. (Rautatieto 2023)

Rautatieto Oy

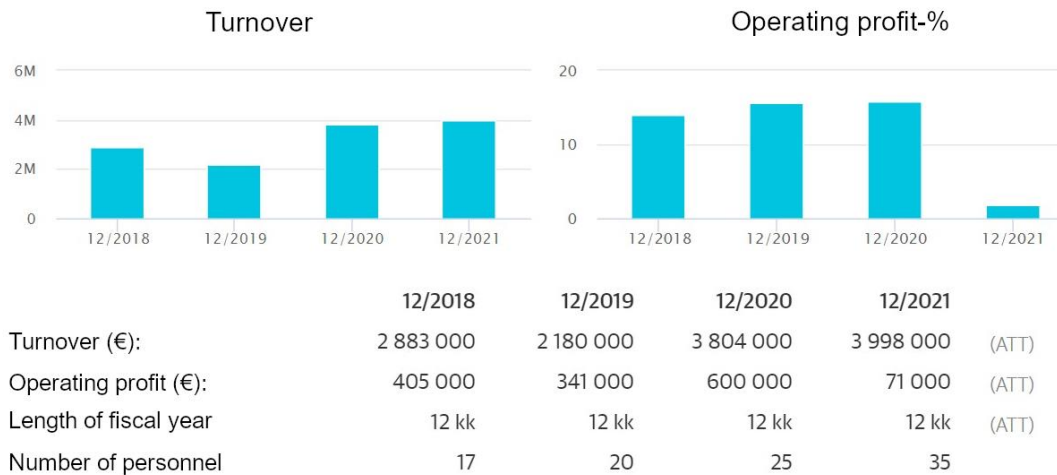

Figure 1. Rautatieto´s financial information. (Kauppalehti 2023a)

2.2 Sundström Ab, Oy Entreprenad

Sundström Ab, Oy Entreprenad was founded in 1966, specializing in the construction and asphaltting of roadways, as well as earthmoving, forestry, and construction of railroads in Finland. Located in Lepplax, the company has approximately 150 employees with a turnover of 82,7 million euros. (Sundström 2023)

According to Kauppalehti.fi Sundström Ab, Oy Entreprenad produced a net profit of 4.14% on its turnover of 85 145 000€ at the end of the 2021 financial year, resulting in a 3 525 000€ profit. (Kauppalehti 2023b)

Sundström Ab, Oy Entreprenad konserni



Figure 2. Rautatieto´s financial information. (Kauppalehti 2023b)

3 LEVEL CROSSING

3.1 Overview

A level crossing is the point of intersection between a railway section and a road. Level crossing may include cycle ways in addition to footpaths. A level crossing provides a safe unobstructed route across a railway for the public. (Office of Rail and Road 2023)

The Finnish railway network had approximately 2600 railway level crossings in use at the end of 2021. These figures take into account level crossings situated on main lines as well as side lines. In addition to the level crossings situated on national rail networks, level crossings can be located on private tracks, e.g., factories and ports. It is estimated that there are several hundred level crossings on private tracks. (Finnish Transport Infrastructure Agency 2023a)

Currently there are two classes of level crossing in Finland: Guarded and un-guarded level crossings.

3.1.1 Un-guarded level crossing

The term Un-guarded level crossing refers to a level crossing that does not have a warning system. This does not include level crossing markings or road signs. With the majority of level crossings in Finland, at an estimated 75%, being un-guarded. Level crossing in this class is only placed in location with light traffic and where visibility is sufficient to see an oncoming train from afar, for example in rural areas. The safety of un-guarded level crossing can be greatly improved by converting it into a guarded level crossing. (Finnish Transport Infrastructure Agency 2023a)



Figure 3. Un-guarded level crossing. (Pennanen, S. 2022)

3.1.2 Guarded level crossing.

Guarded level crossings refers to a level crossing that is equipped with a warning system. These warning systems are as follow:

- Barriers / Gantries: Barriers lower across the level crossing, preventing road traffic and pedestrians from crossing the railway line as a train approaches. When the train has crossed the level crossing, the barriers will lift, allowing passage for road users. (Finnish Transport Infrastructure Agency 2023a)
- Road signal lights: Changing from a single flashing white light to two flashing red lights as a train approaches, signal lights serve as a warning signal for approaching road traffic or pedestrians. When the train has crossed the level crossing, a single flashing white light indicates that road traffic can cross the level crossing safely. (Finnish Transport Infrastructure Agency 2023a)

- Sound warning systems: Sound warning systems start to ring as a train approaches the level crossing and subsides when the train has passed over the level crossing. This serves as an early warning system to road users. (TRAFICOM/251470/03.04.02.00/2019)



Figure 4. Guarded level crossing.

3.1.3 Safety

Level crossings are considered points of high risk on the railways. Not only endangering road users and pedestrians but also posing a great risk to rail traffic and the passengers using rail transport.

With the introduction of Functional safety in Finland, in accordance with IEC 61508, safety as a whole has increased in the railway industry, with stricter testing requirements for railway safety equipment such as signaling systems, in addition to stricter safety inspections with Independent Safety Assessments (ISA) from 3rd party organizations.

The Finnish Transport infrastructure Agency requires a safety integrity level (SIL) of at least 3 for a railway crossing warning systems. In order to receive a SIL 3 certification for an article of safety equipment, the equipment supplier must prove that the equipment is in compliance with the required SIL standards. (Jantunen, E. 2022)

Each hazard detected in the railway network is assigned a Tolerable Functional Failure Rate (TFFR) or Tolerable Hazard Rate (THR) value by the railway network manager. With this value, the railway network manager can therefore define the necessary SIL classifications for the safety function to reduce the hazard on the rail network to a controllable state. (Jantunen, E. 2022)

TFFR [h ⁻¹]	SIL attribution	SIL qualitative measures
$10^{-9} \leq \text{TFFR} < 10^{-8}$	4	Defined in sector specific standards
$10^{-8} \leq \text{TFFR} < 10^{-7}$	3	
$10^{-7} \leq \text{TFFR} < 10^{-6}$	2	
$10^{-6} \leq \text{TFFR} < 10^{-5}$	1	

Figure 5. SIL compared to TFFR value. (Short, R. 2019)

3.1.4 Accidents

Data on accidents occurring at level crossings have been collected by the Finnish Transport Infrastructure Agency since the year 2000 in hopes of improving safety at these points of high risk. As shown in the figure below (see Figure 6) since the year 2000 level crossing accidents have been in a steady decline. This can be attributed to more level crossings being converted into guarded level crossings, in addition to the vast majority of level crossings being removed or replaced by safer infrastructure such as underpasses. (Finnish Transport Infrastructure Agency 2023a)

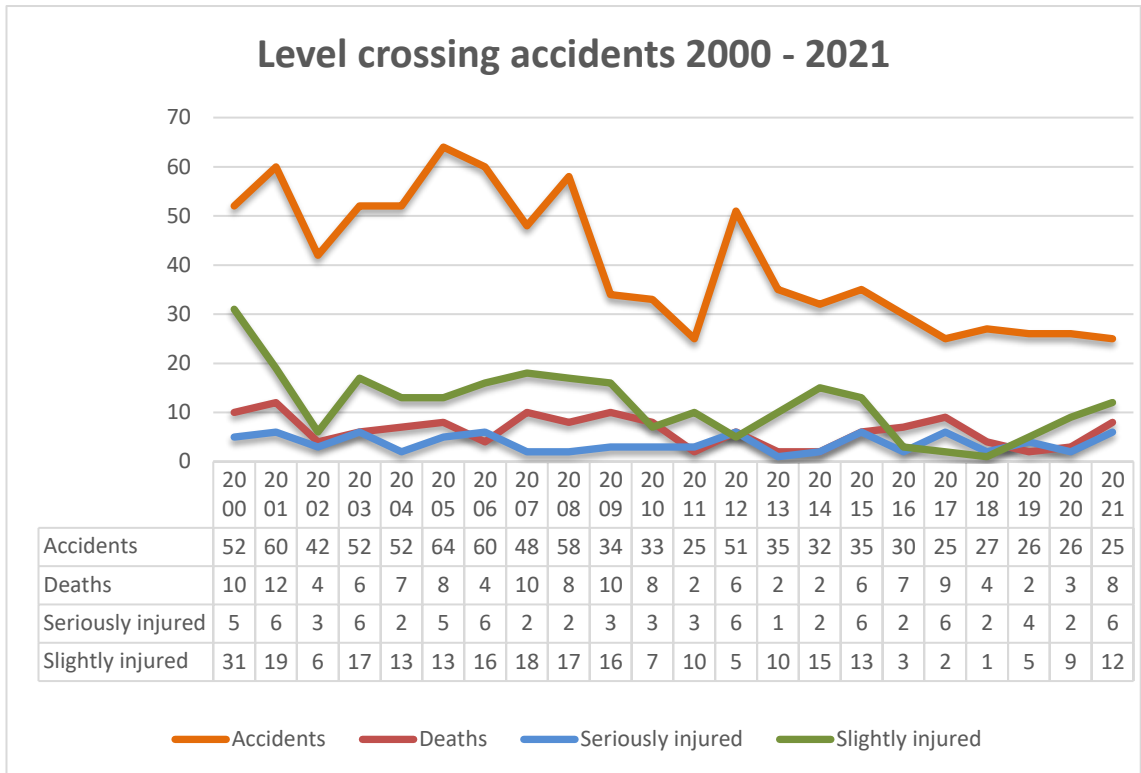

Figure 6. Level crossing accidents 2000-2021. (Adapted from Finnish Transport Infrastructure Agency 2023b)

Most accidents at level crossing happen on side tracks, as the maximum allow speed on a track that has a level crossing is 140km/h. At a railway crossing, the right of way is without exception given to the rail user, in which case road users and pedestrians are obligated to give way to oncoming rail traffic.

Traveling at 80km/h a freight train needs a distance of 825m) to come to a complete stop with a time of 1 minute and 14 seconds (see Figure 7). Indicating the danger of crossing a level crossing while a train is approaching. (Julia 2023)

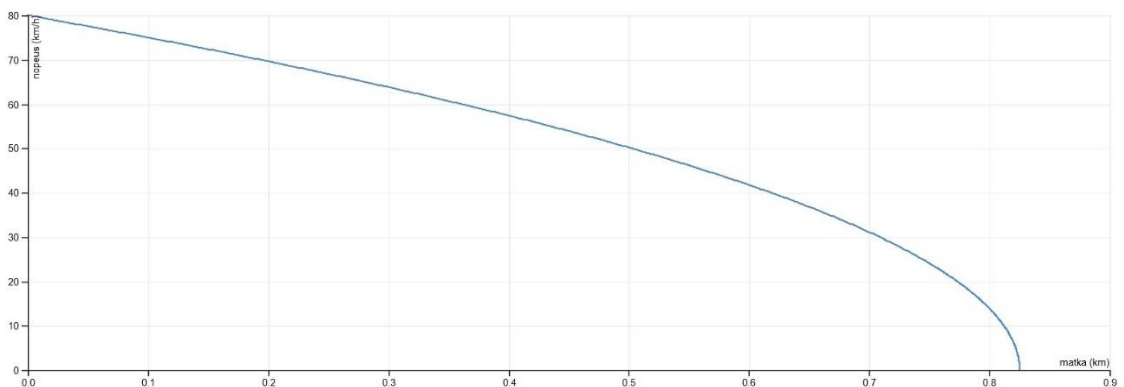

Figure 7. Braking distance for a freight train. (Julia 2023)

3.2 Standards

As shown in the figure bellow (see Figure 9) International and national laws are the basis on which the national railway systems legislation and regulation are implemented, which also include Interoperability Technical Specifications (TSE) based on European Commission regulations. National legislation and regulations are implemented by Trafi. (LO 31/2018, 11)

- Rautatielaki 304/2011 (Railway law)

Applicable IEC and EN Standards that should also be taken into account include:

IEC 61508

IEC 61508 is considered an umbrella standard for the functional safety of programmable electronics, electronics, and electrical safety related systems. The standard covers two fundamental principles: the safety lifecycle and risk analysis.

EN 50126-1:2017

This standard is used for railway applications. The standard covers the Generic (RAMS) process. RAMS is an acronym for Reliability, Availability, Maintainability and Safety.

- **Reliability:** The concept defines the percentage of time that a system is available compared to the need for the system. Techniques such as fault tree analysis can be used to determine reliability. (FSES 2023)
- **Availability:** The concept defines the percentage of time a system has not failed and is available on demand. (FSES 2023)
- **Maintainability:** Is the concept of maintenance, the frequency of maintenance can improve the availability and reliability of a system. (FSES 2023)
- **Safety:** The concept covers the safety of a system and how RAM combination impacts a system. (FSES 2023)

EN 50128:2011+A2:2020

This standard is used for railway applications and defines the technical requirements and software development process for programmable electronic systems when used in safety-related systems.

EN 50129:2018

This standard is used for railway applications and discusses best practices for optimal performance of safety related systems including their subsystems and equipment.

EN 50159

This standard is used for railway applications that discussed the safety requirements for electronic safety systems that use open transmission systems for communications purposes.

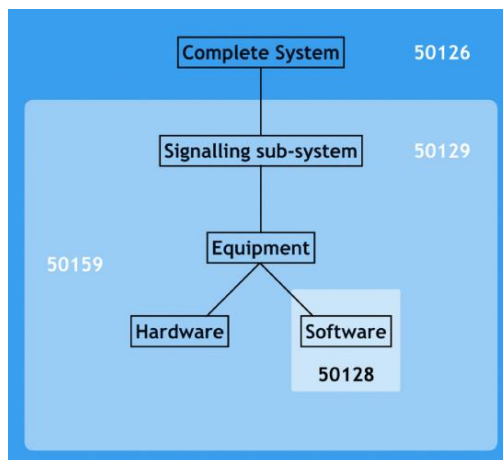

Figure 8. Railway application standards. (AdaCore 2023)

Requirements of the design principals for projects, based on the aforementioned laws, decrees and regulations are approved by the Finnish Transport Agency.

The general internal hierarchy of the Finnish Transport Agency's guidelines are as follow:

- RATO – Technical guideline for rail.
- JT - Safety guideline for train traffic and switching work.

- TURO - Safety guidelines for railway maintenance.

An Emphasis has been made to including legislation and regulation put forth by Trafi, in addition to general technical specifications and requirements presented in the regulations of the European Commission, into the technical guidelines, which must not be deviated from. (LO 31/2018, 11)

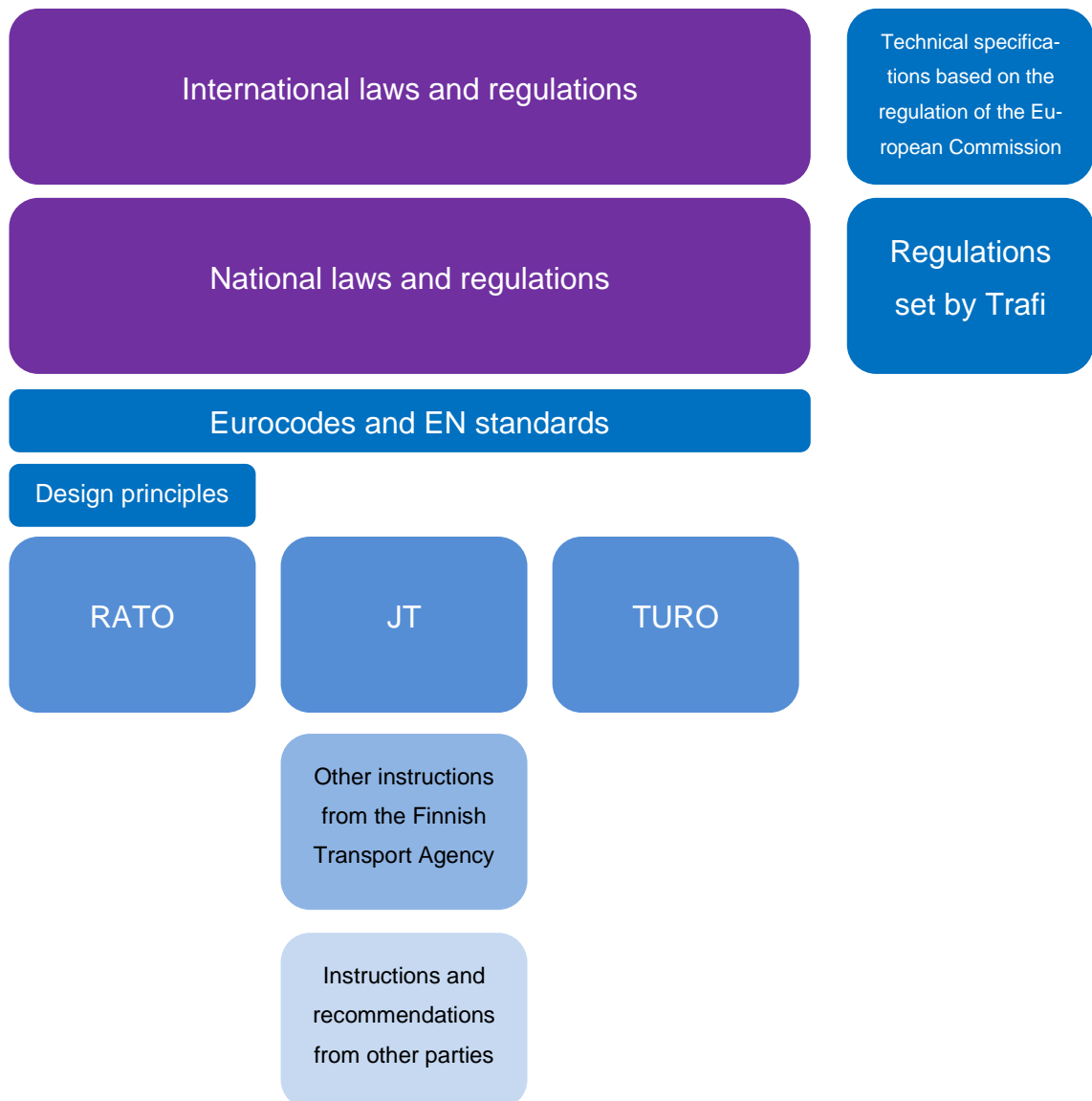

Figure 9. Hierarchy of regulations and instructions of the Finnish railway system. (LO 31/2018, 12)

RATO part 1 defines the General principals of the Finnish railway system. RATO part 6 defines Signalling systems, that covers the design, construction, and maintenance of signalling systems. RATO part 9 defines Level crossings, that covers the building, renovation, or improvements to a railway level crossing on the state rail network.

4 SAFETY PLC

4.1 Overview

A safety PLC (Programmable Logic Controller) is a PLC design for use in safety-critical applications, such as in equipment and machinery where fail-safe operation and reliability is essential. Unlike standard PLCs, that have a primary use in automation control applications, safety PLCs are designed to meet specific regulations and safety standards, such as IEC 61508. These standards provide guidelines for the development and design of safety systems as well as safety functions that include the use of self-testing, redundancy, and fault-tolerant features. (Grieve, T. 2017)

Safety PLCs include a number of features that improve the overall safety of them, such as inputs and outputs rated for safety uses, self-diagnostic and monitoring functions, and the ability to constantly monitor and diagnose the system for any faults. Another level of safety is achieved by using redundant software and hardware architecture that serves as a back-up, in the event of failure, so that the system can keep on functioning. In addition, PLCs often use more advanced communication methods, such as CAN bus and Ethernet, that allow for real time communication with other control systems and safety devices. (Grieve, T. 2017)

4.2 PLUTO D45

ABB's safety PLC (see Figure 10) is intended for use in safety control systems where the loss of safety functions due to faults are not permitted. This is achieved with the use of self-monitoring and redundancy in the hardware, such as the use of two separate microprocessors that both monitor and control the safety functions, to achieve the correct functions of the logic. The microprocessors constantly compare result between each of them, this ensures the integrity of the data. Each safety output of a Pluto unit is connected to both the microprocessors, this ensures that the output cannot be activated if the conditions of the logic in the application program do not correspond over both microprocessors. (ABB 2023b, 4)

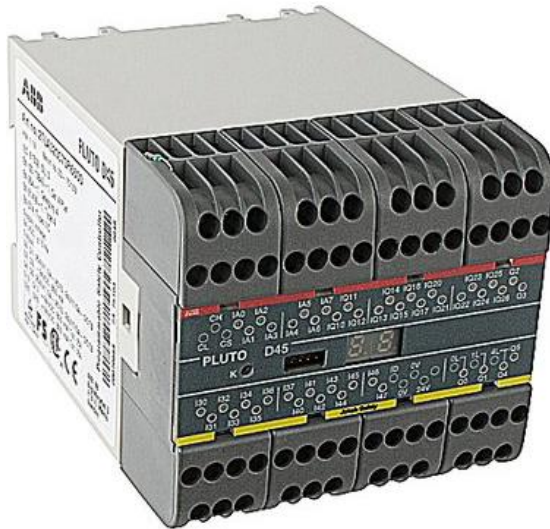
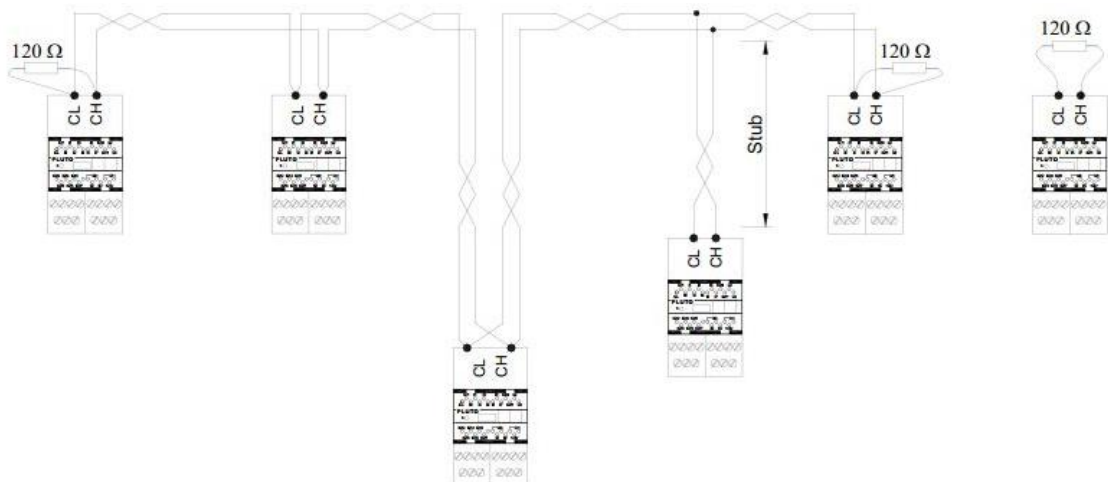

Figure 10. ABB Pluto D45 Safety PLC

ABB's Pluto units can be interconnected with other Pluto units, with the use of the integrated CAN-bus (see Figure 11), this allows the expansions of up to 32 Pluto units if there is a necessity for more input and outputs. Each unit can independently run its own program and logic while at the same time reading the inputs and outputs of other connected units. If at any point communication is lost to a unit, other units will continue to run their programs, but consider all the inputs and outputs of the "dead" unit as false. If these inputs and outputs are part of a second's units' program, that program will not execute as a safety feature. (ABB 2023b, 40)



Connection of CAN bus: CH to CH and CL to CL.

A terminating resistor in each end of the bus. Stubs are restricted to certain max length and shall not have terminating resistor.

Figure 11. ABB Pluto CAN-bus (ABB 2023b, 40)

4.3 HMI

A CP600 HMI (Human Machine Interface) (see Figure 12), can be connected to all Pluto models using the COM port on the HMI and the Pluto programming port. It is also possible to use a RS232 interface along with Modbus ASCII. Even though Pluto is a safety PLC, an HMI panel is not designed for safety applications and should not be used to alter the state of a system. (ABB 2023a, 3)



Figure 12. Pluto CP600 HMI (ABB 2023a)

4.4 Safety

Pluto was designed so that it fulfils the demands regarding the safety of control systems European Union Machinery directive (2006/42/EC). However, the system can be used in other applications, such as in the railway industry that have similar requirements. As such Pluto is designed to meet the IEC 61508 standards at a safety level of SIL 3. For a system to fulfil the standards of IEC 61508, the entire system, including relays and sensors in the system need to comply with these standards, not only the Pluto unit. (ABB 2023b, 4)

As shown in the connection example bellow (see Figure 13), the loss of the safety function will not be lost, due to a failure of a contactor. The safety function is also monitored since the inputs are connected to a NC-contact.

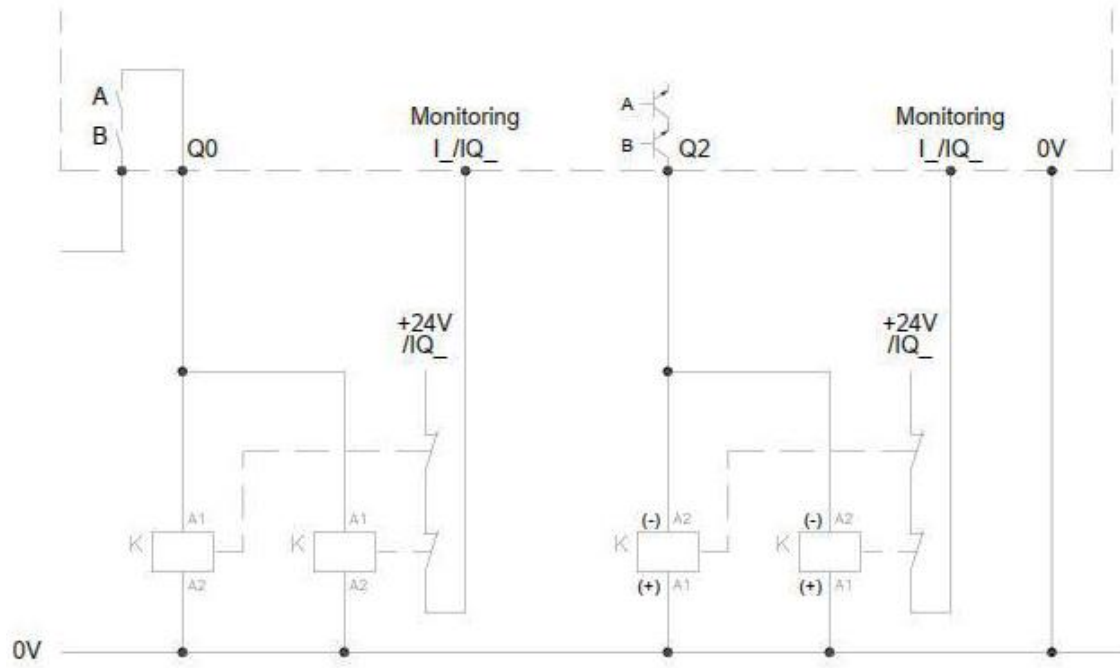

Figure 13. Pluto contactor connection & monitoring. (ABB 2023b, 36)

5 AXLE COUNTERS

Axle counters are devices used to detect the presence of trains in a track section, as an alternative to track circuits. Axle counters detect the wheels of the train using sensors that detect the distortion of magnetic or electric fields (see Figure 14). (RailSystem 2023)

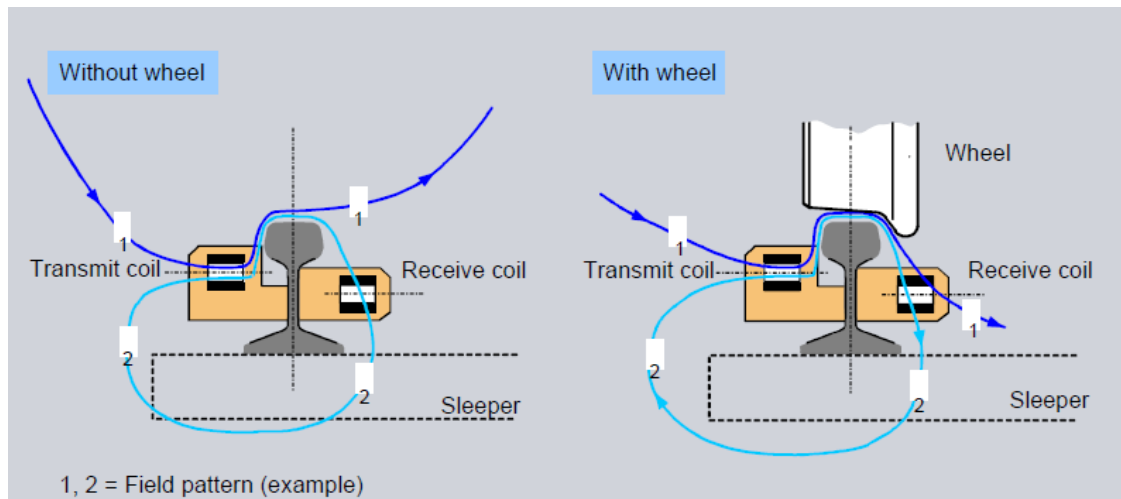

Figure 14. Axle counter wheel detection. (RailSystem 2023)

The system consists of two main components, the counting heads, installed at each end of the track section and the central processing unit (CPU) called the evaluator, that counts the difference between the counting heads (see Figure 15). (RailSystem 2023)

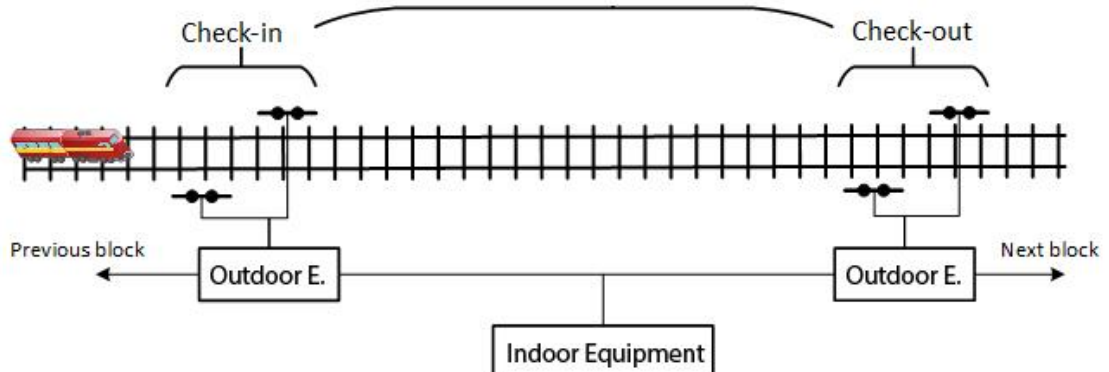

Figure 15. Axle counter layout (RailSystem 2023)

Axel counters have several advantages of track circuits. They are more accurate with the detection of individual axles and can detect the direction of travel of a train. They can be used over greater distances and aren't affected by weather conditions or poor track maintenance. (RailSystem 2023)

Frauscher axle counter, such as the RSR180 (see Figure 16) can be attached to the rail with the use of a "rail claw", in this case technicians do not need to drill holes for the counting head, reducing the time of the personnel on the tracks and speeds up maintenance. (Frauscher 2023)



Figure 16.RSR180 Axle counter with rail claw. (Frauscher 2023)

6 OBJECTIVE OF THE THESIS

The objectives of this thesis set out to answer the following questions, with the primary objective broken down into two parts:

6.1 Primary objective – Part 1

The first part of the primary objective sets out to answer the following question with the results discussed in chapter 8:

What specifications of a Finnish railway level crossing needs to be analysed to design a fault inducing device that can be implemented in a level crossing for educational purposes?

6.2 Primary objective – Part 2

The second part of the primary objective sets out to answer the following questions with the results discussed in chapter 9:

How to design a fault inducing device, that can be implemented into a Finnish railway level crossing system, for educational purposes? (See 9.1 - 9.4).

What the requirements are, to implement and commission an HMI panel that displays simulated faults in the level crossing system? (See 9.5).

6.3 Secondary objective

The secondary objective sets out to answer the following questions with the results discussed in chapter 10:

What type of education material is effective and the type of environment the material would be most effective in? (See 10.2).

How the specifications of a level crossing system effect the educational material, as well as the environment the material is used in? (See 10.3).

7 METHODOLOGICAL IMPLEMENTATION

7.1 Development method

The process consists of analysing technical data and drawings, in addition to analysing manuals of the device/-s and adapting the documentation to fit the needs of this thesis, this also includes an in-depth analysis of level crossing standards by the Finnish Railway Infrastructure Agency.

This method promotes the understanding of the system in full, aiding in the design process. This leads to the generation of accurate documentation and manuals on the system for commissioning and educational purposes.

7.2 Development stages

Stage 1: Analysis

This stage will consist of analysing technical data, drawing, standards, and manuals. This stage includes the process of redrawing and digitising physical drawing into DWG format for future use and ease of implementing changes.

Stage 2: Development

The development of the fault inducing device will take place in this stage. This stage will focus on the design of the new device and the accurate recreation of possible faults that can be induced in the level crossing.

Stage 3: Revision

With the design complete, a second designer and expert reviews the designs of the device. Revisions to the existing design will be made in this phase if needed.

Stage 4: Documentation

After the revision phase, the documentation of the device will be completed, including commission guidelines if necessary.

7.3 Results and reporting

Each stage sets out to build on the previous stage with an analysis of the stage when that stage is complete. This will in return increase the understanding of the system in full, as well as result in a better understanding of the work that was performed in that stage.

The result of each stage should be as follows:

- Stage 1: A full analyses of the current system including technical drawings.
- Stage 2: First draft design of the fault inducing device with an analysis of the possible faults for the system.
- Stage 3: Revised design of the previous stage with a report of the system fault inducing function.
- Stage 4: Documentation for commissioning and educational purposes.

8 LEVEL CROSSING ANALYSES

To achieve the objective a full functional analysis of a level crossing was performed, that included operating modes, components, faults, and technical drawing. This was stages 1 of the process to achieve the results of the thesis, discussed in section 0.

8.1 Functions and operating modes

8.1.1 Track section

A level crossing consists of three track sections as indicated on the figure below (see Figure 17). The alarm sections of the track marked with "B" and the road section of the track marked with "C". Sections of the track marked with "A" are rail sections leading up to the level crossings alarm section. (RATO 6, 145)

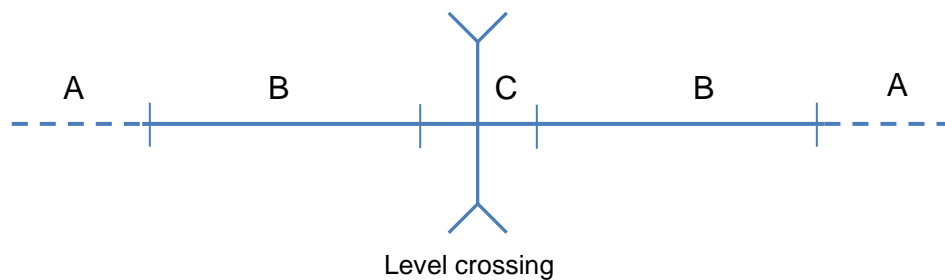

Figure 17. Level crossing track sections

8.1.2 Basic state

A level crossing is in its basic state, when there are no trains present on the railway track section of the level crossing. In its basic state, a level crossing's barriers must be upright at a 90° angle relative to the road, with the road signal displaying a slow flashing white light, with the warning alarm bells not ringing. (RATO 6, 144)

8.1.3 Alarm state

The level crossing activates its alarm state when a train occupies the track section the level crossing is situated on. When the alarm track section becomes occupied, the level crossing's alarm bells start ringing in addition to the road signal displaying fast-flashing red lights for the Pre-alarm time. The pre-alarm time can last for a minimum of 10 seconds and for every 10m between road barriers an addition 1 seconds should be added to the pre-alarm time. After the pre-alarm time has elapsed, the level crossing barriers lower to 0° or parallel respective to the road. Once the barriers pass the 60° angle, the lights on the barrier start flashing. Once the train occupies the road section of the level crossing, the alarm bells stop ringing. When the road section of the level crossing is no longer occupied the barriers rise back to 90°. Once the barriers cross over the 60° angle, the road signal's flashing red lights stop flashing and a slow-flashing white light is displayed. (RATO 6, 144) The time for these events is displayed in following table (see Figure 18).

	Function	Required time	Note
1.	Pre-alarm time	≥ 10s	Note the mutual distance of the barriers
2.	Time reserved for the barriers to lower to horizontal position	10s	
3.	Time reserved for the barrier, which closes the lane leading away from the level crossing, to lower to a horizontal position.	8s	Only for level crossing system equipped with double barriers
4.	Safety time	10s	

Figure 18. Alarm length and the sequence of a level crossing, before a train at a set speed arrives at a level crossing. (RATO 6, 145)

In the case of a level crossing that is equipped with double barrier, the barriers of the lanes that are leading the level crossing must lower after the pre-alarm time, and the barriers of the lanes leading away from the level crossing must be lowered 10 seconds after the barriers of the leading lanes have begun to lower. In the event that a level crossing is not equipped with a barrier, the pre-alarm time must be a minimum of 20 seconds before the arrival of the train at the road section of the level crossing. (RATO 6, 145)

8.1.4 Automatic operation

A level crossing in its automatic operation must activate its alarm state when the alarm track sections (see 8.1.1) become occupied, when all conditions for the activation are met. (RATO 6, 145)

A level crossing is in its automatic state when the following condition apply:

- Only the described track sections control the alarm state of the level crossing. (RATO 6, 145)
- The level crossing is not in a faulty state which prevents the operations of the automatic functions. (RATO 6, 145)
- The level crossing alarm state has not been manually activated. (RATO 6, 145)
- An interlocking system does not prevent the function of the automatic system. (RATO 6, 145)

In the event that an alarm section becomes occupied and then subsequently becomes vacant, with no other track section becoming occupied, the level crossing must remain in its alarm state for 40 seconds. The alarm state must not be deactivated, in the event that one of the alarm's pre-conditions are met within the 40 seconds. (RATO 6, 146)

8.1.5 Manual operation

The level crossing's alarm state can be activated by the use of the alarm switch (TK) in the equipment room, or with the use of the track side alarm button (TR ON). The alarm must end when the alarm switch is returned to its basic state and when the track side alarm button is used the alarm must end with the use of the TR EI button. (RATO 6, 146)

A level crossing can be disabled by the use of operation switch (KK). Alarm bells must stop ringing and road signal lights must be turned off when the level crossing

is disabled. Long alarm faults are dismissed with the use of the return button (PAL). (RATO 6, 146)

8.2 Configuration and components

8.2.1 Road signals

A guarded level crossing must be equipped with a road signal. In the basic state: i.e., when the warning system is not active, the signal must display a slow flashing white light 30 (-0% + 30%) times a minute. When the level crossing is in its alarm state, the signal must display a fast-flashing red light 60 (-0% + 30%) times a minute. With the most common signal resembling an upside-down triangle, with a single white light at the bottom and two red lights at the top. (RATO 6, 154)

8.2.2 Gantry system

Level crossing gantry systems (see Figure 19) consist of a number of elements with their own requirements, these elements are as follow:



- 1 – Motor
- 2 – Break
- 3 – Friction break
- 4 – Switch
- 5 – Spring mechanism

Figure 19. Level crossing gantry system

Barriers / Boom gates

Barriers lower over the road section to prevent road users from crossing the railway as a train is approaching. Barriers should be positioned so, that in respect to the road they are protecting, they are as perpendicular as possible, and their dimensioned should allow them to protect a single lane or foot path. Barriers are monitored in the horizontal position (0°), the vertical position (90°) and in the intermediate position (60°). When power is lost the barriers automatically lower to the 60° position. (RATO 6, 155)

Barriers can be installed in the following combinations:

- Full Barriers: Close a single intersecting lane completely, as well as light traffic lane, as illustrated in part B (see Figure 20). (RATO 6, 155)
- Half Barriers: Close a single intersecting lane and is used when a double barrier is not required to close off a vehicle lane, as illustrated in part A, B, D (see Figure 20). (RATO 6, 155)
- Double Barriers: Close both lanes on either side of the level crossing, as illustrated in part C (see Figure 20). (RATO 6, 156)

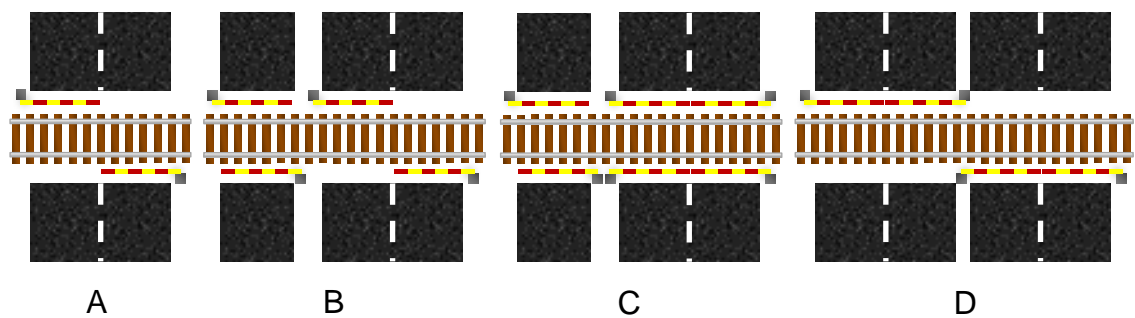

Figure 20. Barrier layout

Motor

Level crossing gantry motors can have nominal voltages of 24VDC $\pm 15\%$ or 50Hz, 380/220 VAC $\pm 10\%$. These motors must still function with values of

24VDC $\pm 15\%$ or 50Hz, 380/220 VAC $\pm 10\%$. Damage to the motor is prevented with a motor-circuit switch set to around 7A. (Dnro 2252/0820/2011, 38)

Break

To lock the barriers in their 0°, 60°, and 90° positions, the gantry system makes use of a magnetic break. In an alternating current motor, the break uses 48V $\pm 20\%$ and in a direct current motor the break uses 24V $\pm 30\%$. When the break is de-energized the barriers lower to the 60° position and the barrier lights start flashing. (Dnro 2252/0820/2011, 37-38)

Friction clutch

The friction clutch in the gantry system is used to prevent damage to the motor or e.g., a vehicle, if the barriers lower on top a vehicle. The friction clutch limits the torque the motor can exert on the barrier. A barrier between 3,5...7m, weighing around 3,6 kg/m is limited to 40...80kpm, with the additional use of a counter-balance arrangement. (Dnro 2252/0820/2011, 37)

Switches

Adjustable limit switches close as the barriers reach their end limits (0° and 90°) in addition to the intermediate position (60°). An additional hand crank limit switch cuts the motor circuit off once the hand crank is inserted into the gantry systems cabinet. This prevents the operator from injury when manually raising the barrier. Limit switches are protected with 2A/ 24V fuses and should have minimum IP44 protection rating. (Dnro 2252/0820/2011, 37-39)

Spring mechanism

The spring mechanism lowers the barrier to a 60° angle respective to the road, in the event that the motor becomes de-energized, or the break fails. The spring mechanism is adjusted so the output torque is 20...40kpm. In addition to the above-mentioned functions, the spring also dampens the barrier when approaching the end limits. (Dnro 2252/0820/2011, 39)

8.2.3 Alarm Bells

Level crossing must be equipped with alarm bells that are audible in all directions of the level crossing, with the alarm bells situated on the road signal mast. Alarm bells ring at around 100 times a minute (RATO 6, 156)

8.2.4 Buttons and switches

- TK Switch: Alarm switch activates the level crossing alarm. A level crossing should be equipped with at least two TK switches. One switch located inside the equipment room, and one located in a cabinet attached to the outside of the equipment room with the KK switch (see Figure 21). (RATO 6, 158)
- TR ON Button: A track-based alarm button, that activates the level crossing alarm when pressed (see Figure 22). (RATO 6, 158)
- TR EI Button: A track-based button, that deactivates the level crossing alarm when pressed (see Figure 22). (RATO 6, 159)
- KK Switch: The operation switch is used to deactivate the level crossing and is located in the same cabinet as the TK switch (see Figure 21). (RATO 6, 159)
- PAL Button: The return button is used to clear long alarm faults while shunting work is performed, the button is located in the rail-side box. An indication lamp of a long alarm fault must be installed alongside the PAL button (see Figure 22). (RATO 6, 159)
- PP Button: The rail-side elimination button is used to allow shunting work to be performed without the level crossing activating on the tracks with alarm sections where the work is being performed (see Figure 22). (RATO 6, 159)
- PP EI Button: The rail-side "PP EI" button works alongside the "PP" button to re-activates the alarm sections, the "PP" button deactivated (see Figure 22). (RATO 6, 159)



Figure 21. KK & TK Switches

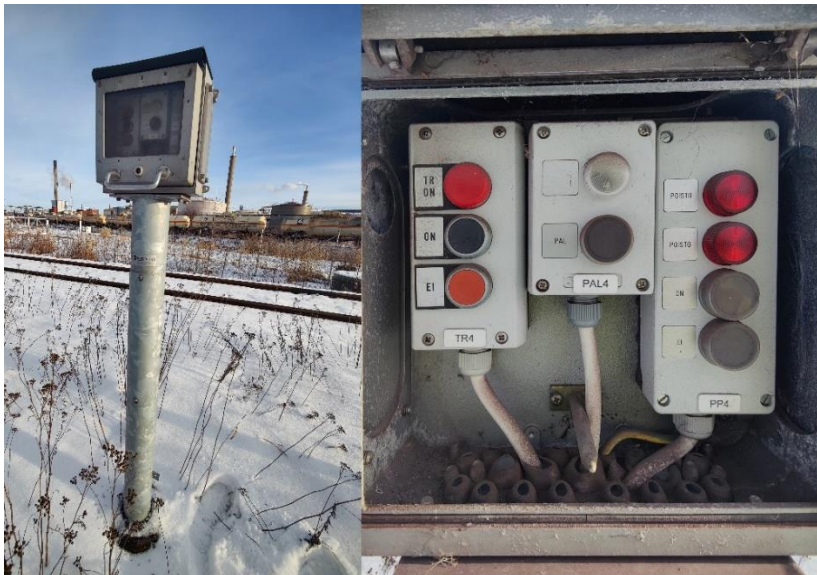

Figure 22. Track side buttons

8.2.5 Equipment room

Equipment rooms are located near the level crossing. The equipment room contains the level crossing's circuits, PLC, relays, batteries for reserve power, technical drawings, and manuals. Equipment rooms can be a track-side cabinet or a separate hut (see Figure 23). (RATO 6, 159)



Figure 23. Track-Side equipment cabinet (Left) & equipment hut (Right)

8.2.6 Automation

The automation of a level crossing can be achieved by either using signalling relays or a safety PLC.

Relay

C-type K50 signalling relays are used in older level crossings in Finland. These include pre-assembled relay groups that control sections of the automation and individual relay connections. (Liikenneviraston oppaita 5/2013)



Figure 24. Relay group (Left) & K50 signalling relay (Right)

PLC

Finnish level crossing uses a number of different safety programmable logic controllers (PLC) to control the automatic functionality on a level crossing. PLCs from manufacturers such as Siemens (Simatic S5), ABB (Pluto), and HIMA (HIMatrix) can be found in level crossings.

For more information on PLCs, refer to chapter 4, where safety PLCs are discussed in detail.

8.2.7 Track vacancy monitoring

Track circuit

Track circuits use alternating current (AC), direct current (DC) or audio frequency (Hz) circuits. These circuits can be set up to be fed from the track section extremities or be centre fed. The circuits are set up in such a way, that when a short circuit occurs between the two rails, the track section becomes occupied, with every subsequent track section having the polarity reversed for DC circuits, different phases for AC circuits and different frequencies for audio frequency circuits. When the track section is short circuited the track relay is de-energized to indicate a section of track is occupied. (RATO 6, 165)

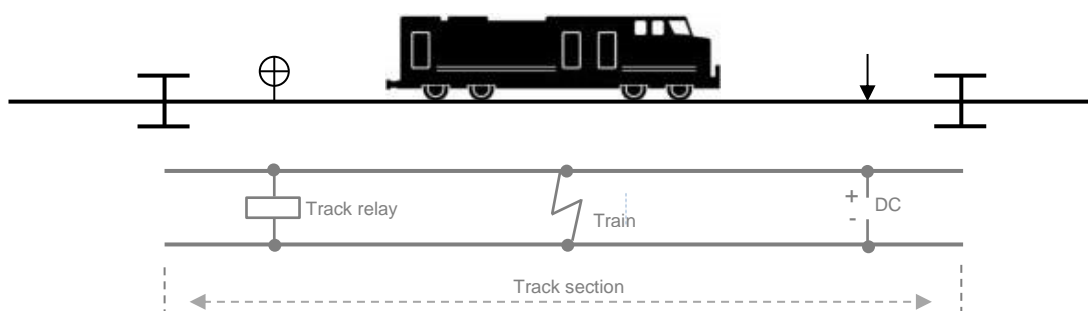

Figure 25. Track circuit

Axle counters

A track section can make use of axle counters to prove its vacancy. Axle counters are inductive devices counting the number of axles in and out of a track section,

if the number of axles into the track section are greater than the number of axles out, the track section is considered occupied. (RATO 6, 44)

For more information on Axle counters, refer to chapter 5, where axle counters are discussed in detail.

8.2.8 Level crossing signal

A level crossing signal is situated as close to the start of the road track section as possible, with a visibility of at least 50m. Level crossing signals should not be installed on tracks with speeds exceeding 35kph. (RATO 6, 122)

Level crossing signals have two white lights one above the other. A single white light (top) signalling “approach with caution” and a double white light signalling “No aspect”. The signal light displays the “No aspect” signal when the level crossing has given an alarm for the required time and no critical faults have been introduced into the system. In all other cases the signal will display “approach with caution”. (RATO 6, 29)

8.3 Level crossing analyses - Faults

A level crossing’s system faults are divided into critical and non-critical faults, with critical faults preventing the completion of the alarm sequence. Only after the critical fault has been rectified, is the level crossing alarm sequence able to continue. System fault alarm information must be forwarded to the local control centre or to a location, pre-determined by the Finnish Transport Infrastructure Agency, in addition a white light mounted on the outside of the equipment room indicates that the level crossing is in a state of fault. (RATO 6, 148)

8.3.1 Critical faults

Reliability fault

When the conditioned are met for the level crossing to activate its alarm state or lower the barriers, but the alarm is not activated, or the barriers are not lowered the level crossing has a reliability fault. (RATO 6, 149)

System fault

System faults occur when the control system prevents the level crossing system from activating. (RATO 6, 149)

Barrier fault

A barrier fault is introduced, in the event that the level crossing cannot monitor the barrier condition, due the barriers monitoring circuit indicating a fault. (RATO 6, 149)

Earthing fault

When a part of a circuit isolated from the earthing potential, contacts the earth potential, an earthing fault occurs. (RATO 6, 149)

Long alarm fault

A long alarm fault can occur when the alarm section of a track has become occupied without the road section being vacant for over 10min or the road section is occupied, and the alarm sections are vacant for over 10min. The barriers should rise to 60°, this excludes double barriers. If the alarm section becomes occupied again, the long alarm fault carries on. A level crossing with a level crossing signal should indicate the "Approach with caution" aspect and the level crossing alarm must end 20 seconds after the level crossing signal indicates "Approach with caution". (RATO 6, 149)

Barrier position monitoring fault

In a situation where the barriers do not lower to the 0° position in the required 10 seconds a barrier fault occurs. (RATO 6, 149)

Road signal fault

When the road signal cannot display a red light, a road signal fault occurs. (RATO 6, 149)

8.3.2 Non-Critical faults

Low-voltage alarm

Low voltage alarms are the product of the power being cut to the level crossing and the accumulated currents in the power banks running low. (RATO 6, 150)

Lamp fault

A lamp fault can occur due to a multitude of reasons: (RATO 6, 150)

- The road signal cannot display a white light.
- The road signal can only display a single red light.
- A main or spare filament fault is detected in the road signal.
- A main or spare filament fault is detected in the level crossing signal.

Operation fault

An operation fault occurs in the situation, where the level crossing's system alarm is active, but none of the conditions are met for the alarms to be in an active state. (RATO 6, 150)

9 DESIGNING A FAULT INDUCING DEVICE

Follow the analyses phase in chapter 8, the design principles of the railway industry were analysed and how they can be implemented into the results of this thesis. In addition to the technical design, the possibility of implementing an HMI was explored. This was stages 2 of the process to achieve the results of the thesis discussed in section 0.

9.1 Design principals

The design principals and techniques used for the technical drawing are an adaptation of German railway design principals and techniques. All circuits are drawn in an energised state or the “basic state”. This implies that circuit breakers are drawn as if they are closed with current going through them, in addition to relays and their operating contacts being drawn energised or de-energised depending on their basic state (see Figure 26).

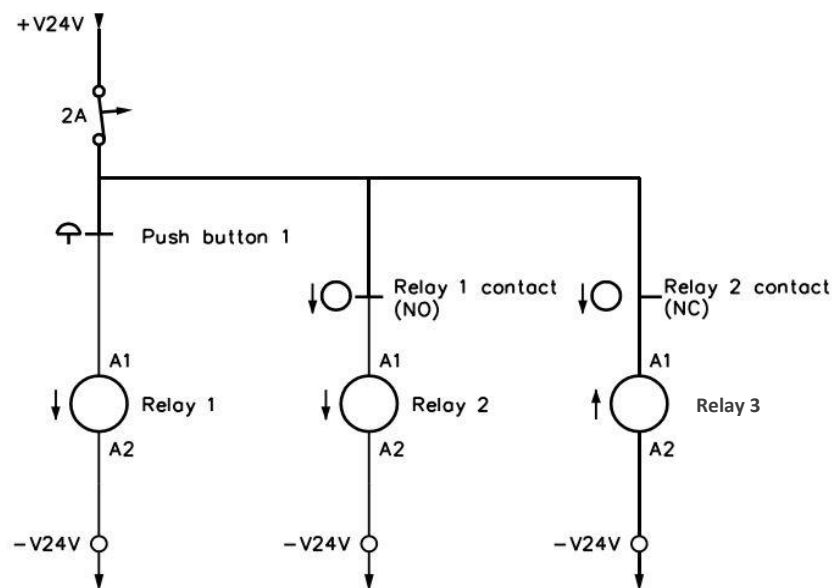

Figure 26: Basic state design

With the above figure (see Figure 26), as an example of a basic state design, we can follow the current of the circuit with the thicker black lines. “Push button 1” disrupts the circuit for “Relay 1”, that’s in a de-energized state. Relay 2’s circuit is disrupted by a normally open contact of “Relay 1”, putting “Relay 2” in a de-

energised state. “Relay 3” is in an energised state. This will be considered the basic state of the system. If “Push button 1” is pushed, “Relay 1” will become energised, opening its contact that will energise “Relay 2”. Once “Relay 2” is energised, its contact will disrupt the circuit for “Relay 3”, de-energising it.

Designing the circuit in an energised state, reduces the amount of design errors, as the designer can see in what state each relay should be and the consequences of a particular relay on a circuit. This also improves the speeds of the fault-finding process and the ability to find faults in a circuit if a technician has a clear design of the circuit in question. A technician can always refer to the technical drawings and see the basic state of each relay, if the relay is not in the basic state, and it should be, the fault is likely to be connected to that circuit.

9.2 Fault finding principles.

With the design principles discussed in the section 9.1, if a level crossing is in a state of fault, a technician can follow the circuit up from the relay that is inducing the fault and look for any contacts that are not in their basic state, that could be the cause of a fault. This form of fault finding works on a “ladder” principle (see Figure 27).

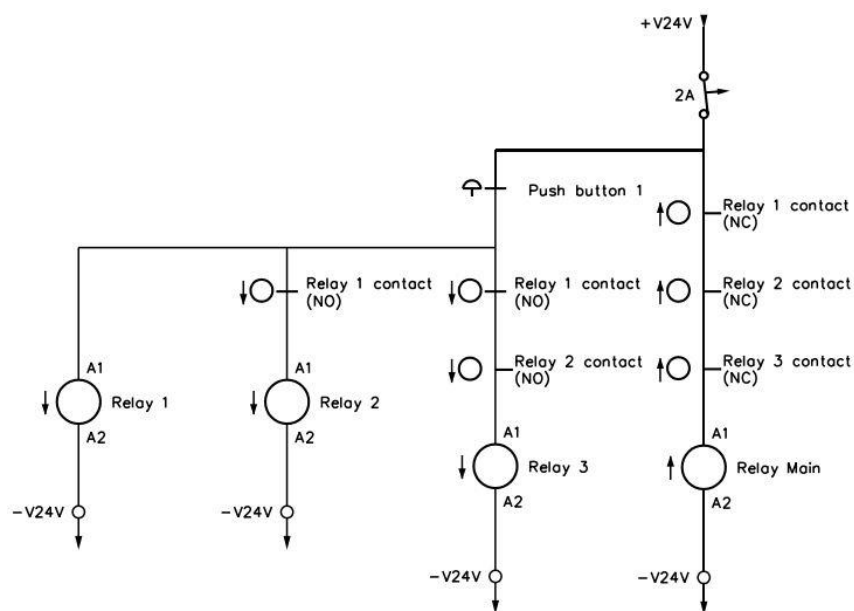

Figure 27. Ladder fault finding

In the example above (see Figure 27), it is possible to see, that if any of the contacts above the main relay are closed, the main relay will become de-energised. If the main relay is de-energised, we can follow the “ladder” up and see which contact is closed that should be open. If “Relay 1” becomes energised, relays 2 and 3 will also become energised, and the main relay will become de-energised. If by chance relay 3 becomes energised, relays 1 and 2 will stay de-energised, but the main relay will become de-energised.

This form of “ladder” fault finding has been shown to be some of the most effective fault-finding techniques, when searching for faults in relay-based logic systems. The technique gives the technician the ability to see what the basic functional state of the circuit should be and compare it to the state that the circuit is in. In addition, the technician can see what the conditions are for each part of the circuit, to function in the basic state.

9.3 Fault inducing circuit.

9.3.1 Design of the circuit

By using the ladder fault finding principle, it is possible to design a circuit in such a way that it promotes fault finding in educational use. The design makes use of relays that disrupts the basic state of the level crossing's circuits and can introduce the desired fault in the level crossing system.

The process started with the analyses of the level crossing technical drawings and pinpointing the circuits and relays that would cause system faults in the level crossing. As seen in the figure bellow (see Figure 28), the basic state of the Tpvar relay is energized, this implies that while the level crossing is in the basic state with no faults present and no train approaching the Tpvar relay will stay in the energised state. If the barriers' Tp1 or Tp2 control circuit becomes disrupted Tpvar will become de-energised and indicate a barrier fault in the level crossing system. The fault can be located by either looking at the basic sate of the relays or in a PLUTO PLC system the PLC's digital display will display a fault code in this case UE-12 (see Figure 29).

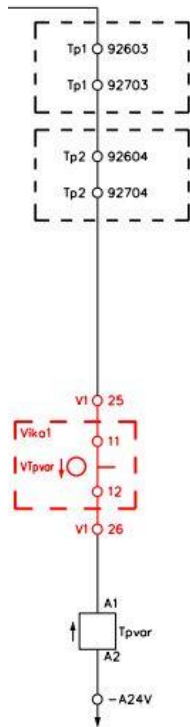

Figure 28. Tpvar fault relay



Figure 29. Tpvar relay (Left) and Pluto Fault code (Right)

After the identification of the circuits and relays that cause faults in the system, a relay was added, marked with a “V” in front of the name of the original relay, to be able to induce a fault in the system on demand. As seen in the figure above (see Figure 28), the contact 11/12 for VTpvar in red, is placed just above the Tpvar relay. When needed the VTpvar relay can be energised with a push button

(see Figure 30) that causes the Tpvar relay to become de-energized and cause the system to go into a faulty state.

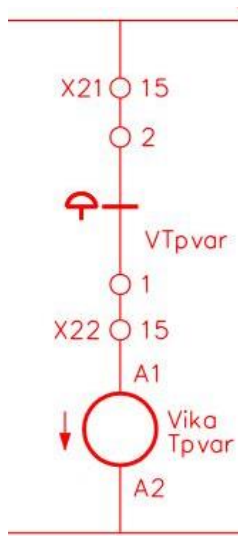

Figure 30. VTpvar fault relay

When a fault relay becomes energised, a red indicator LED lights up, by use of a second normally open (NO) contact in the relay. This is an indicator for the operator, as to what fault was activated (see Figure 31). If needed the indicator LEDs can be deactivated, without effecting the function of the device. This is achieved by having the LEDs on a separate circuit (see Figure 32).

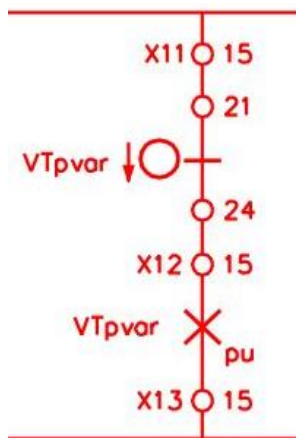

Figure 31. VTpvar indicator LED

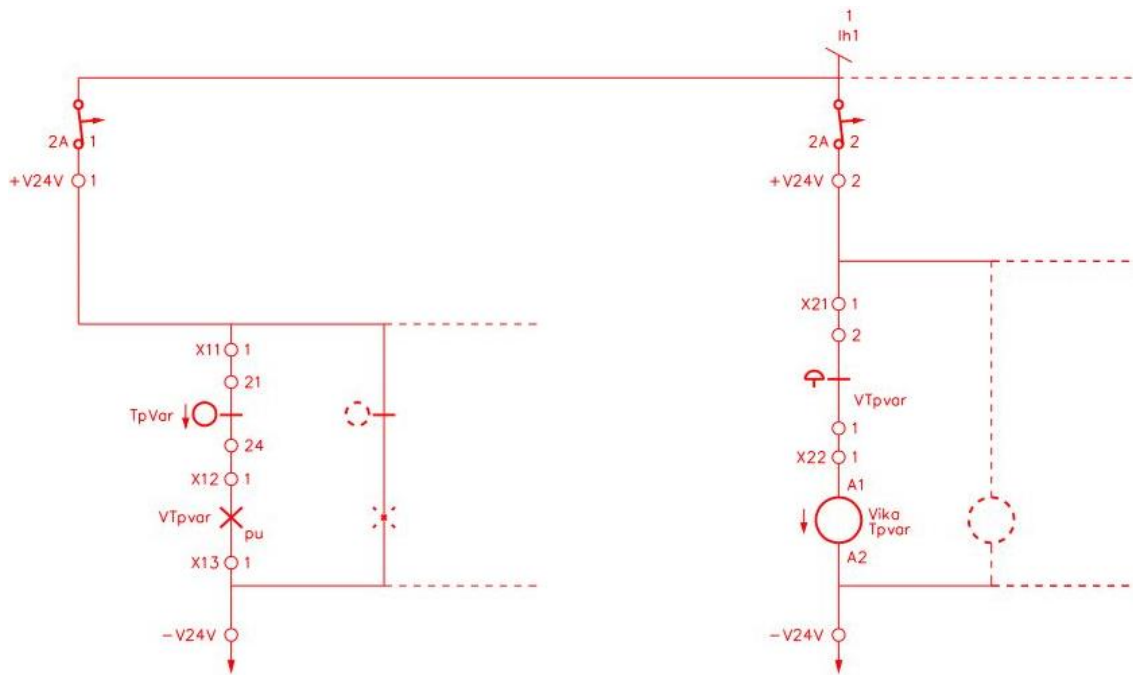

Figure 32. LED and Relay separate circuit

By having a relay that disrupts the basic state of the circuit, a technician can identify a fault by either looking at the state of the relays in the case of a relay-based circuit or by inspecting the fault code on the PLUTO PLC in a PLC system. This introduces the possibility to easily adapt the fault inducing circuit for a variety of level crossings or technicians' skill levels.

If a better overview of the circuit is required, refer to appendix 1, where the full circuit is presented.

9.3.2 Restrictions of the device

The device is designed in such a way that it alters the circuit of the level crossing. Because of the alterations to the circuit, the level crossing cannot be used on the national rail network without being restored to its original condition and been verified by a commissioning inspection.

The device is designed for educational purposes only and is not allowed to be used on an active level crossing on the state railway network.

9.4 Physical device

The device was designed in a small enough cabinet, in such a way that it can be easily moved if mounted on a trolley system or mounted in a fix position on a wall. With the use of HC cable connections, the device can be disconnected from level crossing system and a HC jumper connector can be connected to restore the level crossing system to a basic functional level crossing. Each HC connector, LED, relay, and push button is connected to a separate feed-through terminal block. This design choice was made to simplify the process of exchanging a faulty part or making changes to the circuits if needed.

A basic layout of the level crossing is printed on the door or the cabinet (see Figure 33 & Figure 34); LEDs are presented with crossed out circles and push buttons are represented with hexagons. A push button is added for each fault that can be simulated and a red LED light connected to the button to indicate what fault is active. Indicator lights on the cabinet door also indicate the class of fault that is active. A yellow LED for a non-critical fault and a red LED for a critical fault.

The inner and outer layout of the cabinet is presented in appendix 2 in the event that more information is needed.

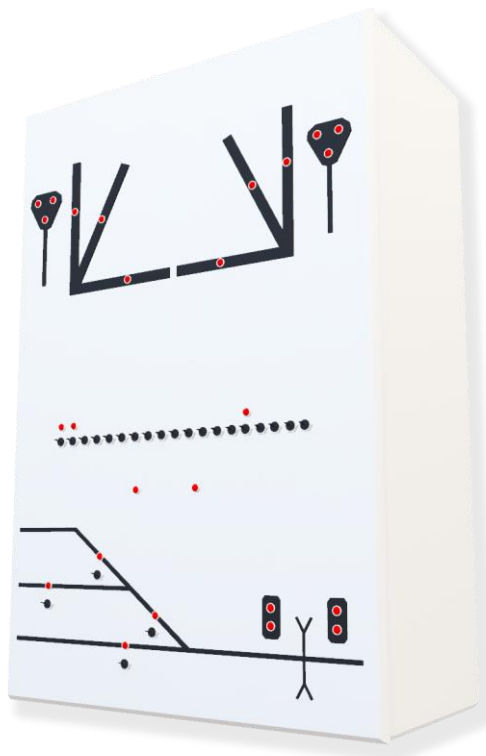

Figure 33. Cabinet

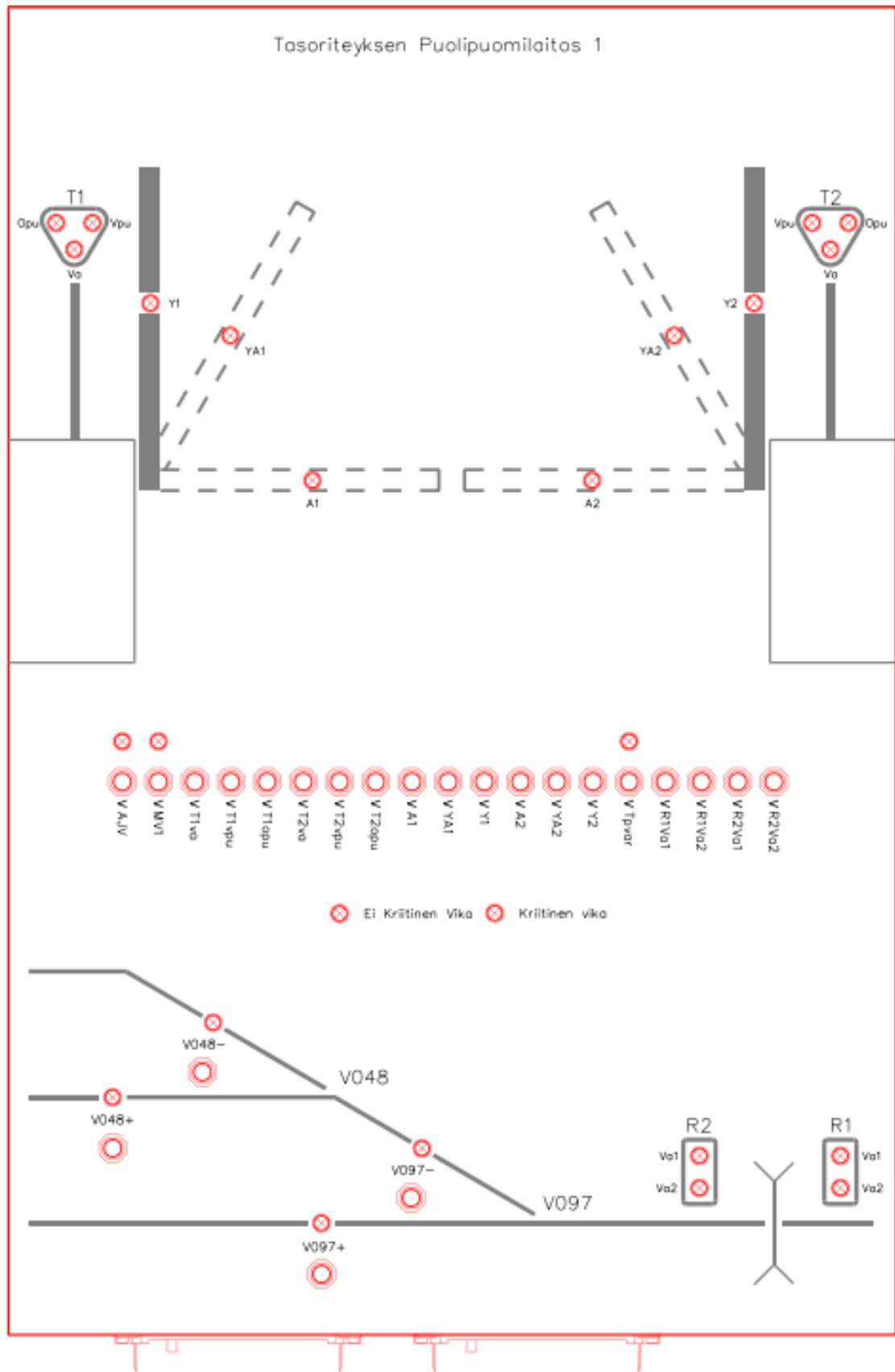

Figure 34. Cabinet door

9.5 Implementation of an HMI Panel.

With the use of a the CP600 HMI's programming port, it is possible to connect any Pluto unit's COM port or connect the Pluto unit with Modbus ASCII and a RS232 interface. With the help of ABB's "Pluto Manager", that is used to create and read projects on a Pluto device, the tags and variables from a project can be exported (see Figure 35). These variables can be imported into ABB's "Panel Builder" software, in which it is possible to build an HMI for the CP600 panel (see Figure 36). (ABB 2023a, 6-10)

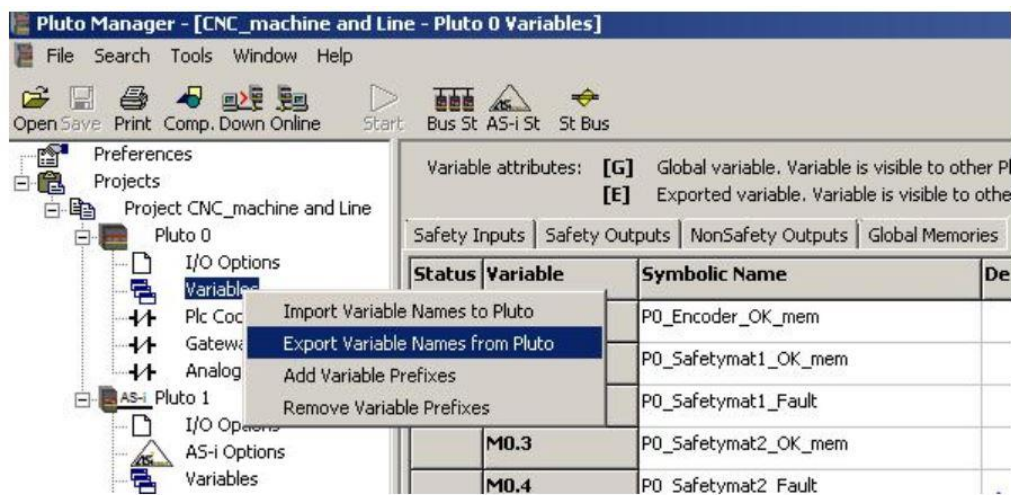

Figure 35. ABB Pluto Manager (ABB 2023a, 6)

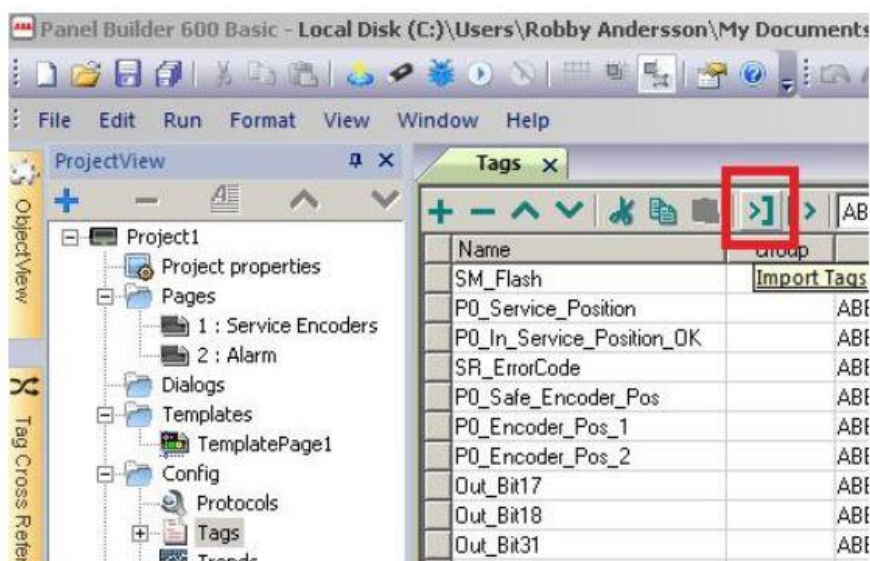

Figure 36. ABB Panel Builder (ABB 2023a, 12)

Even though Pluto is a safety rated PLC, the CP600 HMI panel is not designed for safety applications and should not be used to alter the state of a system. In addition, no alteration can be made to the logic on the PLC, as this alters the safety rating of the logic and must be re-certified for use in the railway industry. Thus, the HMI can only be setup in a read-only state if the existing version of the on-board logic has been certified with the capability to implement an HMI.

Because the HMI does not need control the level crossing and is set up in a read-only state for the simulation of faults, it is possible to use the outputs of the safety PLC as the inputs for a cheaper PLC that does not need to meet the requirements a safety PLC does as illustrated in the figure bellow (see Figure 37). The output Q1 of the Pluto D45 PLC is connected to the input of the Siemens S7 PLC. This could be achieved with a compact PLC and HMI. The minimum requirements for this type of PLC are as follow:

- 28 Digital inputs: These inputs will come from the safety PLC and the axle counters.
- 28 Digital Outputs: These can be connected to indicator LEDs.
- HMI connection.

The following example PLC setup can be used for basic simulations:

- 1x Siemens S7-300, 312C compact CPU
- 2x Siemens S7-300 Digital I/O Module, 8 Inputs, 8 Outputs
- Siemens TP700 comfort panel

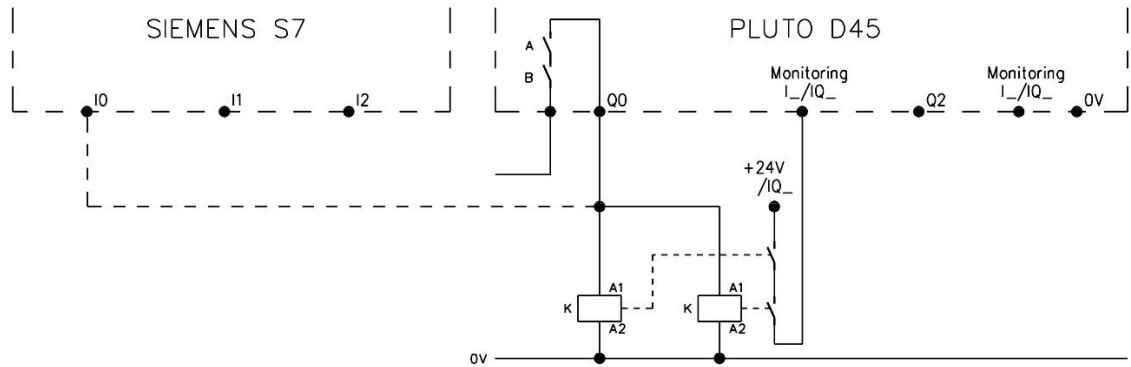

Figure 37. Safety PLC connection to HMI PLC

With the use of Siemens' "TIA portal", basic logic can be set up and an HMI can be designed for the simulation. This can be exported to the CPU and run in parallel with the safety PLC only reading the output that the safety PLC, Pluto D45 in this case, produces. With no effect on the original signalling systems safety logic.

A basic HMI can display the barriers, track sections, critical / no-critical faults and road signals (see Figure 38). The addition of a "pop-up" window that displays information such as the types of faults can be implemented along with a history log. Addition to the HMI can be made depending on the type of track and the type of training that needs to be done.

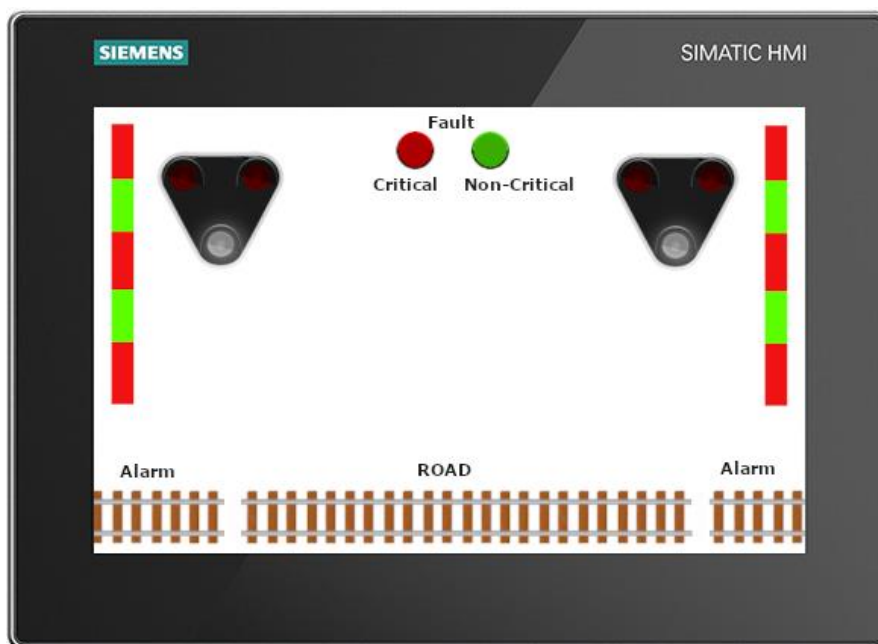

Figure 38. Basic HMI setup

9.6 Challenges during the design phase.

One of the challenges during the analyses phase of the thesis, was the realisation that there was a second level crossing connected to the first level crossing. These level crossings use the same alarm track section in addition to using same track switch information to control the level crossing. This called for revisiting the location and doing a second inspection to document the second level crossing.

Another challenge that became apparent during the analyses, was that the level crossing needed the rail switch information to function properly, but the switches would not be acquired with the level crossings. This led to the situation that a switch simulation circuit had to be designed to replace the missing switch information (see Figure 39).

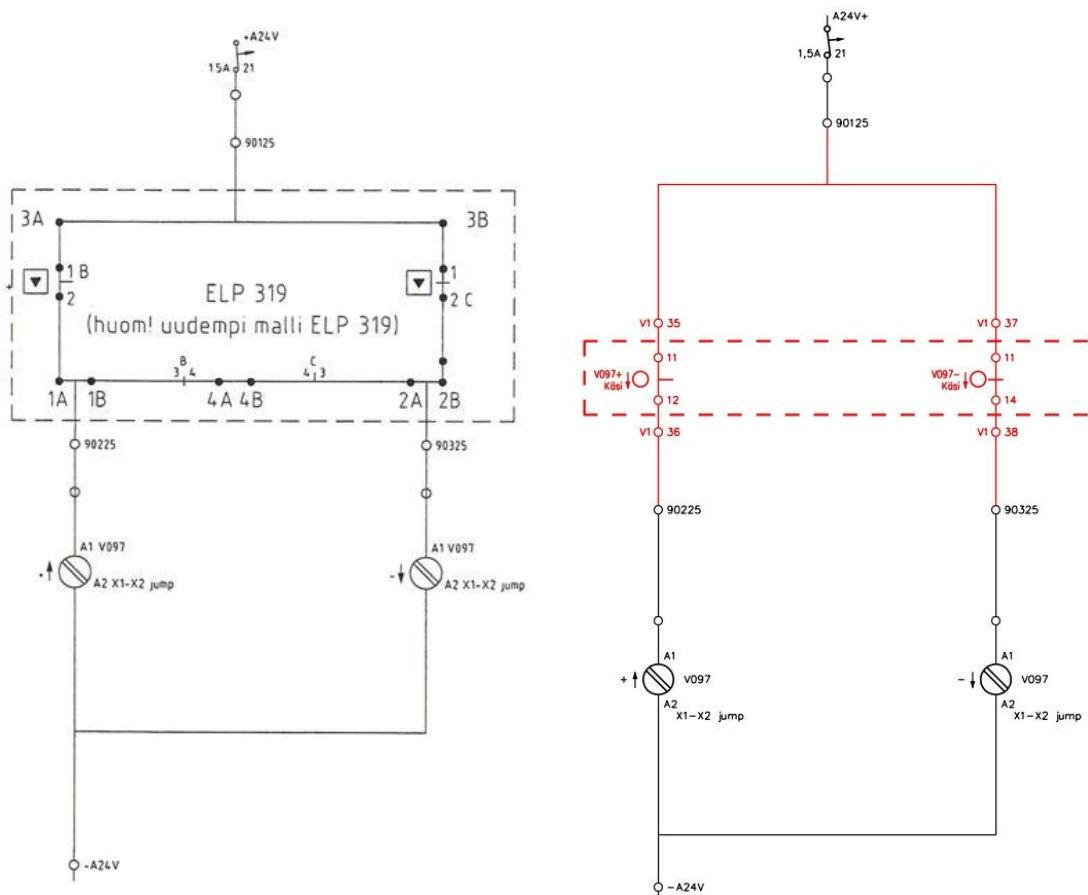

Figure 39. Switch simulation

The ELP 319 switch was replaced with two relays: a normally open relay and a normally closed relay. This design functions as a simulated switch. The relays are controlled by switches, that the controller can use to simulate the function of the switch, as well as simulated a possible fault in the switch. This challenge became a feature of the fault inducing device, as it adds a second aspect to the railway crossing that is not seen as often.

10 EFFECTIVENESS OF TRAINING

The objective was achieved by relaying on previous experience in the field of current experts in the railway industry, as well as personal experience. By using what was learned during the analyses and design phase of the thesis, effective educational material can be created in addition to analysing the effects of training depending on the environment it is used in.

10.1 Field test

During the process of the thesis a total of five technicians were taken along to a PLC-based level crossing and a relay-based level crossing on separate occasions. Three of these technicians were trained as signalling system junior technicians and two junior technicians who did not receive signalling systems training yet. Two of the trained technicians were told to read up on the basic maintenance instructions provided to them, in hopes that they were able to locate a fault the following day. An introduction to the “ladder” fault finding principle was given to the other trained technician and the junior technicians, as well as given a basic overview of each level crossing system.

For each technician the same barrier fault was induced in the level crossing system. The PLC-based level crossing displayed the fault code, but the technician should know where to look in relay-based level crossing, with the use of the ladder fault finding principle.

The technicians that were given the task to study up on the level crossing had a significantly more difficult time locating the fault. They were scrambling through all the possible documentation in hopes of finding answers. After around 30 minutes both had to be shown where to look to find the fault.

The remaining technicians immediately started looking for the faults in a controlled systematic way. The faults were located in under 10 minutes by both the junior signalling systems technician as well as the two inexperienced technicians.

10.2 Effective education process and the impact of the environment in which it is used.

By taking the result of the field test into account as well as relying on personal experience of senior technicians, it can be concluded that a “show and tell” process, with technicians having the opportunity to interact with the subject, would be an effective means of training newer technicians on a previously unknown systems.

Junior training

An effective way to introduce new technicians to a subject could be to do a crash course with hands on experience of system and explain the basic. After this crash course introduce the theory of said system. This would allow the technician to have a better understanding of what they are being introduced to. After they have revised the theory part of the training, they can be reintroduced to the system with a better understanding of what the system`s function is as a whole.

Senior training

The educational process and material can be adapted depending on the experience of the technicians. By introducing more than one fault at a time into the system, a technician has to methodically work up the chain to solve each individual fault. In addition, the theory assisting the technician can be more technical and in dept, providing a broader understanding of the fault or part of the system in question.

Commissioner training

It is also possible to adapt the training in such a way that senior technicians can do commissioning training. Commissioning training would be done in such a way that the technician should be able to test and provide evidence that the level crossing is functional in all states and prove that the faults produced the correct state in the level crossing.

Environmental effects

With current training being done in the field, training technicians without having an actual project that involves a level crossing is a time-consuming process. Technicians can neither explore the level crossing freely while it is in use on the state rail network.

With a dedicated device for training technicians in a safe environment, with the intention of making mistakes and trying to fix them without consequences of fines for the company, makes the process of learning less stressful and more enjoyable. A dedicated educational device can improve the speed of the training novice technicians considerably. This could allow a new experienced technician on a weekly basis. They will not only understand the principles of fault finding in a level crossing system, but their skills can be transferred to other more demanding systems, like Interlocking systems.

10.3 The impact of specification on the educational material.

The impact of a level crossings specifications is minimal on the educational material. With all railway level crossings in Finland designed on the same standards, the basic, alarm, and faults state of each level crossing remains the same.

If training was provided on a particular system, with the basics of fault finding learned by heart, the process can be applied to most other systems. The only hurdle to overcome would be the introduction of a new system and going over those systems specific components. When a technician can read and understand technical drawings, the process of introduction to a new system takes less than half a day.

10.4 Challenges during the data collection phase.

The main challenge was the time and recourses that were required to introduce five different technicians on ten different occasions to the two individual railway level crossing systems. This process took many months and was the basis for this thesis. This particular challenge proved the point, of the amount of time it

takes to introduce technicians to a system and give them training, especially for a smaller company.

11 FURTHER DEVELOPMENT

With the current technical drawings and analysis of the level crossing system, the next step to develop this project further would be the implementation of the plans and use the analysis to implement and plan educational material to accompany the device. This could include the addition of the secondary PLC and HMI panels to display simulated faults and record the outcome for future review if the commissioning company has the budget and need for it.

As discussed in section 10.2, to further develop technicians with greater efficiency and skills and increase the safety factor, the outcome of this thesis can be adapted to suit technicians with different skill levels. The need for educational material that will suit that process can be further developed with the commissioning company and their senior technicians. This would be a cost-effective way of increasing the number of skilled technicians at a greater rate for the commissioning company. With the material also being adapted to better suit training for personnel on how to commission a level crossing system in use, for the personnel seeking commissioning inspection qualification.

12 DISCUSSION

12.1 Review of results

The results that the thesis produced, were what was expected of both parties for the scope of this thesis. The thesis produced technical drawings that included the layout of the fault inducing devices and the circuits drawing for the commissioning of the device. In addition to the technical drawings a list of parts for procurement was also produced to help with the commissioning process and additionally to plethora of documentation that was collected for producing in-depth training material.

Results from the thesis are easily adaptable to fit the needs of the commissioning company; This could include a course that ranges from training junior technicians to commissioning personnel. The results also produced a technician and designer with a good understanding of Finnish railway crossing systems that can easily fill the role of commissioning personnel.

12.2 Examination of reliability

All information regarding the design of the level crossing system such as design principals and laws were obtained from the Finnish Transport Infrastructure Agency's official documentation. All standards used while producing the thesis were either from EU-standards for the railway industry or the adapted EU-standards from the Finnish Transport Infrastructure Agency.

Other sources while producing the thesis have been experts in the railway industry. With over 50 years' worth of experience in the railway industry and is one of the main designers of relay level crossing systems in Finland, the information provided by this person can be considered reliable. The information provided by this person was evaluated using standards and principals provided by the Finnish Transport Infrastructure Agency.

12.3 Discussion on learning process

By having access to experts in the railway industry, in-depth documentation on the level crossing and having the ability to inspect the devices, made the learning process as effective as it could have been.

By comparing and combining all three sources of information, it was possible to inspect the physical level crossing while reading up on the standards and design principals. This led to a clearer understanding of why a certain decision was made during the design and implementation phases of the level crossing. When the standards were not clear, it was easily explained by an expert, that could also explain the history of those design principals.

With all the available data and the process of analysing the level crossing in-depth beforehand, the actual design process of the fault inducing device for the level crossing was relatively problem free.

REFERENCES

ABB 2023a. Pluto CP600 Panel Integration Manual. Accessed on 14 April 2023. https://library.e.abb.com/public/198f85e67ecc475e92873975ade72a2c/2TLC172325M0201_A.pdf

ABB 2023b. PLUTO Safety-PLC, Operating instructions Hardware. Accessed on 14 April 2023. <https://search.abb.com/library/Download.aspx?DocumentID=2TLC172001M0212&LanguageCode=en&DocumentPartId=&Action=Launch>

AdaCore 2023. What is EN 50128? Accessed on 14 April 2023. <https://www.adacore.com/industries/rail/en50128>

Dnro 2252/0820/2011. Varoituslaitosten tekniset toimitusehdot 2012. Finnish Transport Infrastructure Agency.

FSES 2023. Reliability, Availability and Maintainability Study (RAMS). Accessed on 1 April 2023. <https://fses.global/service/ram-analysis/>

Finnish Transport Infrastructure Agency 2023a. Tasoristeysten usein kysytyt kysymykset. Accessed on 29 March 2023. <https://vayla.fi/vaylista/rataverkko/tasoristeykset/usein-kysytyt-kysymykset>

Finnish Transport Infrastructure Agency 2023b. Tasoristeystonnettomuudet. Accessed on 30 March 2023. <https://vayla.fi/vaylista/aineistot/tilastot/ratatilastot/tasoristeystonnettomuudet>

Frauscher 2023. Axle Counters. Accessed on 14 April 2023. <https://www.frauscher.com/en/solutions/axle-counting>

Grieve, T. 2017. What Are Safety PLCs? Huffman Engineering Inc. Accessed on 14 April 2023. <https://huffmaneng.com/what-are-safety-plcs/>

Jantunen, E. 2022. Creating Testing Environment for Railroad Level Crossing systems. Bachelor's thesis, Metropolia University of Applied Sciences. Accessed on 1 April 2023. <https://urn.fi/URN:NBN:fi:amk-202203033067>

Julia 2023. Nopeusrajoituslaskuri. Accessed on 30 March 2023. <https://juliadata.fi/nopeusrajoituslaskuri/>

Kauppalehti 2023a. Yrityshaku - Rautatieto Oy. Accessed on 29 March 2023. <https://www.kauppalehti.fi/yritykset/yritys/rautatieto+oy/24120664>

Kauppalehti 2023b. Yrityshaku - Sundström Oy. Accessed on 29 March 2023. <https://www.kauppalehti.fi/yritykset/yritys/sundstrom+ab+oy+entreprenad/15327268>

Liikenneviraston oppaita 5/2013. Releiden käyttö rautatieturvalaitetekniikassa. Finnish Transport Infrastructure Agency

LO 31/2018. Ratatekniset ohjeet (RATO) osa 1 - Yleiset perusteet. Finnish Transport Infrastructure Agency.

Office of Rail and Road 2023. What are level crossings? Accessed on 29 March 2023. <https://www.orr.gov.uk/guidance-compliance/rail/health-safety/level-crossings/what-they-are>

Pennanen, S. 2022. Minkiön aseman taseasteys saa puomin ja valot – "Museaalisuus vähän kärsii, mutta turvallisuus edellä mennään". Forssan Lehti 9 November 2022. Accessed on 30 March 2023. <https://www.forssanlehti.fi/paikalliset/5490546>

RailSystem 2023. Axle Counter. Accessed on 14 April 2023. <https://railsystem.net/axle-counter/>

RATO 6. Guidelines of the Finnish Transport Agency 7/2014 - RATO 6, Signalling systems. Finnish Transport Infrastructure Agency.

Rautatieto 2023. Rautatieto - esittelyaineisto. Accessed on 29 March 2023. Internal source

Short, R. 2019. Does SIL Live up to Expectations? Accessed on 1 April 2023. <https://webinfo.uk/webdocssl/irse-kbase/ref-viewer.aspx?refno=740881177&document=does%20sil%20live%20up%20to%20expectations%20%28aspect%202019%20paper%29.pdf>

Sundström 2023. Sundström yrityksenä. Accessed on 29 March 2023. <https://www.sundstroms.fi/yritys/>

TRAFICOM/251470/03.04.02.00/2019. Rautateiden ohjaus-, hallinta- ja merkinanto-osajärjestelmä. Accessed on 29 March 2023. <https://www.traficom.fi/fi/ajankohtaista/uudet-maaraykset-rautateiden-liikkuva-kalusto-ja-rautateiden-ohjaus-hallinta-ja?toggle=Rautateiden%20ohjaus-%2C%20hallinta-%20ja%20merkinanto-osaj%20A4rjestelm%20A4%20>

APPENDICES

- Appendix 1. Level crossing 1 fault relay technical design
(Confidential)
- Appendix 2. Level crossing 1 fault cabinet layout (Confidential)
- Appendix 3. Level crossing 1 Design (Confidential)
- Appendix 4. Level crossing 1 Cabinet layout (Confidential)
- Appendix 5. Level crossing 2 Design (Confidential)
- Appendix 6. Level crossing 2 Cabinet layout (Confidential)