

Saimaa University of Applied Sciences

Technology, Lappeenranta

Double Degree Programme in Civil and Construction Engineering

Civil Engineering

Filipp Panov

Directional drilling

Bachelor's Thesis 2016

ABSTRACT

Filipp Panov

Directional drilling, 38 pages

Saimaa University of Applied Sciences, Lappeenranta

Technology, Double Degree Programme in Civil and Construction

Engineering Civil Engineering

Bachelor's Thesis 2016

Instructor: Lecturer Sami Kurkela, Saimaa University of Applied Sciences.

The purpose of the thesis was to accumulate knowledge about directional drilling in Russia, to study all regulatory documents and Russian companies which take part in the development of directional drilling in Russia. The status of Russian directional drilling was studied and the development directions were defined.

The first part of the thesis contains the overview of Russian directional drilling. The second part of the thesis contain Finnish approach to the directional drilling, comparison of Russian and Finnish approaches and short view on the development of directional drilling in Russia.

A lot of existing projects and studies in directional drilling in Russia was read and investigated. The conclusions were done and as a result this thesis contains a short overview to the current situation in Russian directional drilling.

Keywords: directional drilling, drilling rig.

TABLE OF CONTENTS

1 INTRODUCTION	
2 DIRECTIONAL DRILLING	5
2.1 Historical reference	5
2.2 Types of methods.....	6
3 DIRECTIONAL DRILLING IN RUSSIA.....	13
3.1 The use of directional drilling in Russia.....	13
3.2 Pioneering in directional drilling	14
3.3 Directional drilling project.....	18
3.4 Russian approach to the directional drilling.....	22
3.5 Quality control	26
3.6 Cost estimation	27
3.7 Work Safety on drilling site.....	28
4 THE ACTIVITY AND DEVELOPMENT OF RUSSIAN SOCIETY FOR TRENCHLESS TECHNOLOGIES.....	29
5 FINNISH APPROACH TO THE DIRECTIONAL DRILLING	32
5.2 Work safety on drilling site	34
5.3 Cost estimation	35
6 COMPARISON OF FINNISH AND RUSSIAN APPROACHES	36
7 CONCLUSION	36
REFERENCES	39

1 INTRODUCTION

There are two ways of piping under roads or other obstacles - open and closed. Traditional methods of piping regardless of the purpose were executed by the open way until recently. This way of piping provides digging trenches to the desired depth, trench preparation for laying a pipe, laying a pipe, communication backfilling, backfilling of the trench and recovery of grass or roadbed. Execution of such types of work associated with different difficulties like safety compliance and violation of lifecycle of a city.

Trenchless technologies are particularly appealing construction options in urbanized area with numerous existing underground utilities heavy traffic: vehicular and pedestrian. Often, trenchless techniques are the only construction option that possible to utilize. Trenchless techniques are also often the least costly option as well as the least disruptive.

The aim of this thesis work is to study such a subdivision of trenchless technologies as directional drilling; to study good and bad aspects of this method; to consider the Russian and Finnish approaches to the directional drilling and to define possible ways of development.

2 DIRECTIONAL DRILLING

2.1 Historical reference

The concept of directional drilling method was developed in the late 1920s in the USA. At first it was inclined rotary drilling with chisels of small diameters. In the Soviet Union the main theories of directional drilling were invented in 1938-1941. Successful borehole drilling in the 'Il'ich Bay' realized by directional drilling method gave the beginning of the implementation of directional drilling in the Soviet Union. Some countries also took the Soviet method of directional drilling, called 'directional turbo drilling', and utilized it on their own territory.(8)

Then directional drilling became popular gradually (because more and more countries started to realize that this method was really cheaper and gave more opportunities in elaboration of soil) and developed step by step. In 1963 the exploration of the new method of directional drilling for the installation of communication, called horizontal directional drilling was began. Horizontal directional drilling was the alternative to the trench method of installation of communication. In 1972 the first orders to use horizontal directional drilling was got. 1980 was the first time when a bundle of 3 tubes was skipped through the 1 horizontal well.(7)

In the Soviet Union researches of horizontal directional drilling was began in the 1930s. In 1957 the horizontal well which was passing on a 30 m depth was conducted. In the 1970-1980s the program to create domestic drilling rig was released. Then economic and political changes which happened in the government influenced negatively on further development of domestic technology of directional drilling. And despite of all Russian achievements in producing of domestic drilling rigs, Russian companies, which have chosen the way of purchasing foreign drilling rigs, were more effective in the development of directional drilling.(8)

However, the given experience and knowledge helped in the 1990s, when some small transitions were made by Russian rigs. Such rigs distinguished from western ones by the fact that on Russian rigs electric drills were used as down-hole equipment when the pilot well was drilled. In the period of 1994-1995 a lot

of possibilities of laying pipelines through water barriers appeared on Russian building market.

2.2 Types of methods

Directional drilling is a common name for all methods of piping with utilizing of special drilling machinery. There are at least four such methods for today and each of them has its own features. All of them are considered in detail below.

The impact moling

The impact moling is a type of directional drilling and it is suitable for cases when it is needed to lay a pipe of small diameter in cramped conditions. This method is as well realized in big cities as in small towns and also when piping under railroads and highways. (5)

The impact moling is produced by a piercing tool (Figure 2.1). An equipment complex consists of rig itself, hydraulic station, main instruments for drilling works and wireless location.

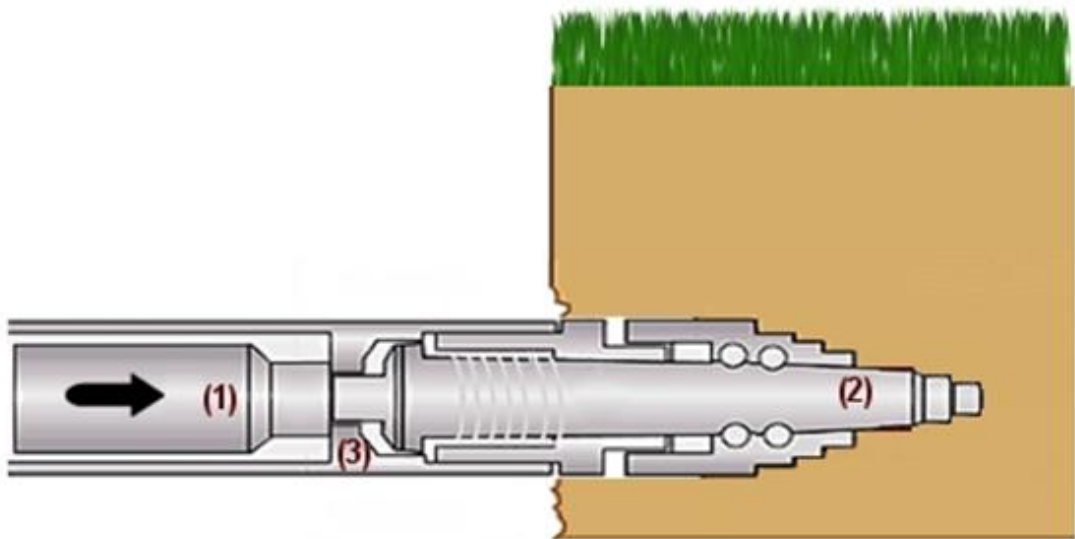

Figure 2.1 The head of impact muling rig: 1 – Piston; 2 – spring loaded chisel; 3 – casing.

The main part of the rig for impact muling is a hydraulic cylinder with the capacity of 36 tons. Two-cylinder four-cycle gasoline engine starts the hydraulic station. The location system consists of a probe, placed in a removable drilling

head and a locator, defining a location at plan, a depth of a drilling head, an angle of vertical inclination and a charge level of a probe battery. The surface of a drilling head is chamfered at the tip, so in case of denting a drilling bundle deflected towards. The operator can watch how to turn the head of the drill in order to correct a trajectory in the right direction through the locator. If a drilling rod is dented with rotation, so the drill bundle moves straight.(5) The principal scheme of impact moling process is shown in Figure 2.2.

After the implementation of horizontal directional drilling the head of drilling rig exits to a receiving ditch, where it changes to a tapered reamer. After that the pilot well extends to a necessary diameter by reversal of rigs with compaction of soil. At the same time or after preliminary extension pipe is jammed through into a finished well.

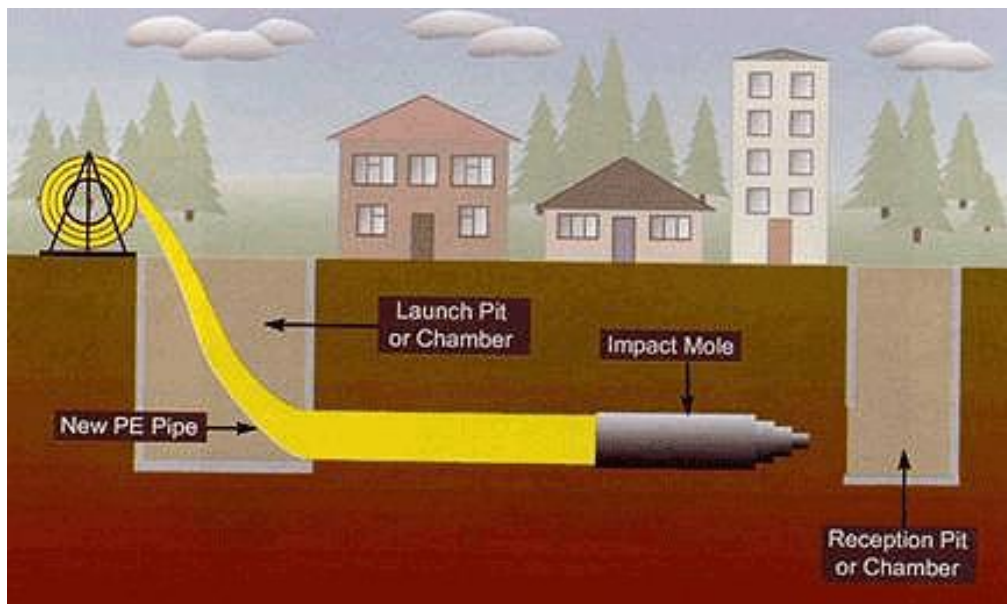

Figure 2.2 The principal scheme of impact moling process.

The impact moling plant works without applying bentonite mortar. The borehole walls keep stability due to compacted layer of soil. The rig can be utilized not only in summer period, but also in winter. (8)

The main characteristics of the impact moling rig are the ease and simplicity of transportation, density, capacity, direction control and high electric safety. This rig is more comfortable when drilling under roads.

The auger boring

The auger boring is a trenchless technology of piping through a hydraulic jacking setting, which is equipped with rotating cutting instrument, launched from a working ditch, with removal of elaborated soil by auger mechanism (Figure 2.3). With the auger boring rig it is possible to implement pipe laying of steel cases, concrete and polyethylene pipes with diameter from 100 to 1720 mm on distances to 100 m depending on soil types.(5)

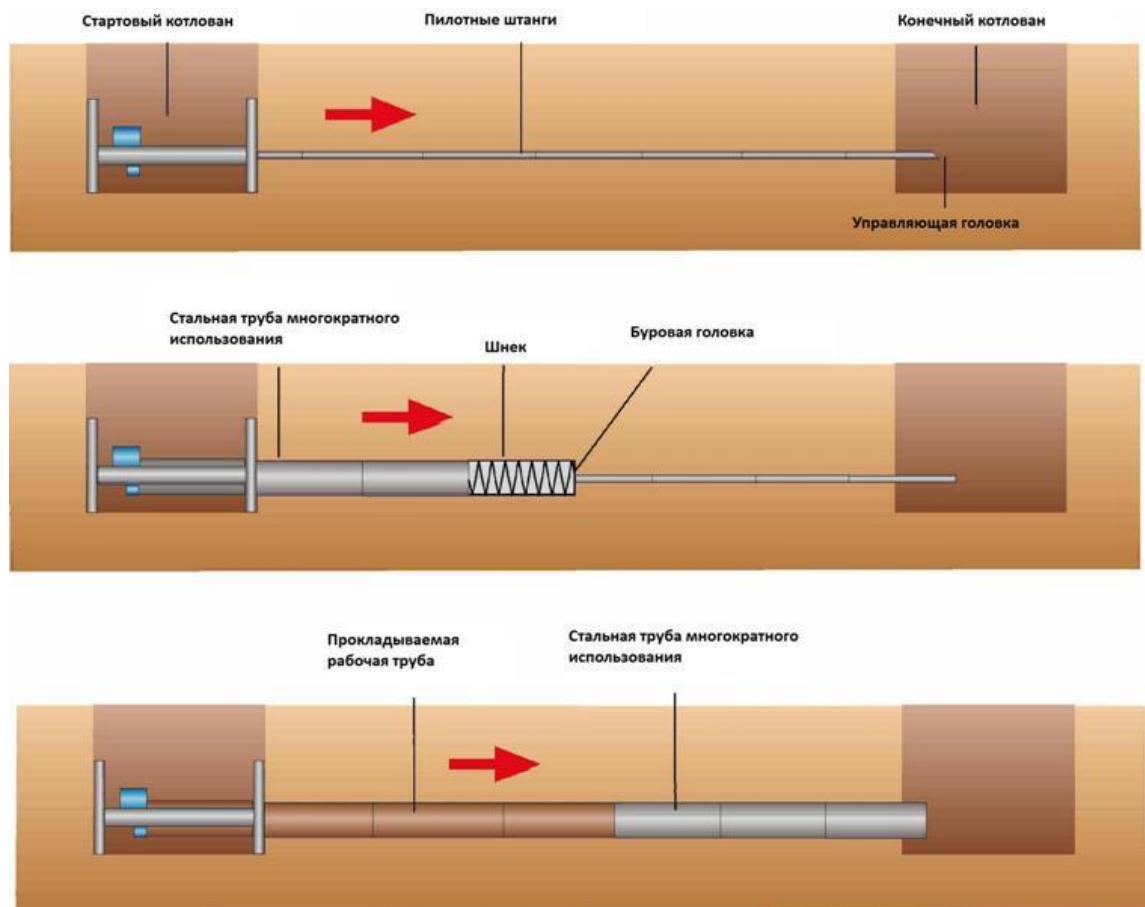

Figure 2.3 The auger boring stages.

It is necessary to have two ditches: starting and adoptive, with the depth lower than pipe laying depth on 0,5-1,0 m in order to release a laying of communications. A powerful jacking station with a pipe ramming mechanism placed on it is mounted in the starting ditch.

On the first stage the preparation of the starting and adoptive ditches is accomplished. On the second stage the descent and installation of auger rig is produced into a ditch. On the third stage the pipe laying is carried out, controlled

by laser. On the final stage the auger is dived to the adoptive ditch and then is pulled out in the reverse order. After that the rig and the augers are extracted from the starting ditch.(8)

Due to special laser control system the auger boring technology allows laying pipes with designed inclination with high accuracy, that very is important in building of a gravity sewer.

The pipe ramming

The essence of the pipe ramming method lies in the fact that the pipe is pushed into a soil by opened end, and the soil, which got into it during the moving of the pipe, is elaborated and removed manually or by hydromechanization tools (Figure 2.4). (5)



Figure 2.4 The pipe ramming machine.

The pipe ramming method (Figure 2.5) is utilized in case of laying pipes with large diameters (from 800 to 1400 mm) and on distances to 80 m. So appeared the necessity of installing two or four hydraulic jacks (in some cases six) working with the capacity of 200-400 tons. The jacks complicate a stop construction, frames for jacks and a tip. The changed performance of such works is about ten meters. (8)

The length of pipe laying with the utilization of one ditch ranges from 10 to 80 m. Longer tracks are divided into parts. The pipe laying is led from each working ditch, at first, in the direction of the first sector, and then in the reverse order.(8) The working and adoptive ditches are prepared to the pipe ramming as in the impact moling.



Figure 2.5 The pipe ramming process in action.

This method of directional drilling has a row of advantages: relatively low costs of work, lack of necessity in expensive equipment, a large number of staff is not required. Control of work and correction of direction are made by a specialist placed in the ditch. The control communication damage avoiding also is led by that specialist.



Figure 2.6 The preparation for pipe ramming.

The pipe ramming method is quite simple. A steel case is pushed by hydraulic jacks, usually consisting of two hydraulic jacks, each 100-200 tons of pushing power. The progress of moving stokes is 1,2 -1,3 m. Jacks and the attached pipe are placed into the working ditch. It must have necessary depth with strengthened walls, which can withstand pressure during the implementation of works. A hydraulic drive, which activates the jacks, is placed on the surface near the ditch. The hydraulic jacks start to push the pipe ramming the soil, by continuously moving.(5) The preparatory process for pipe ramming is shown in Figure 2.6.

The horizontal directional drilling

The horizontal directional drilling method (Figure 2.7) also called directional drilling is one of the most common methods in pipe laying for pressure pipelines and for cable cases. This method also can be applied when laying gravity pipelines, but there are some features.



Figure 2.7 Horizontal directional drilling under water obstacle.

Drilling of a well is implemented from the ground surface. The diameter of the well must be wider on 30-50% than a diameter of a pipe. The well is formed by gradual expansion with applying of bentonite and polymers. The bentonite mortar provides removal of the elaborated soil and bears the walls of the well, excluding collapse. The elaborated bentonite mortar is removed with the soil from the working ditch and moved to a dump. The good-formed well without obstructions and collapses is a deposit of success and trouble-free work.(5)

The length of the laying pipes differs from 25 to 1000 m and longer depending on the pulling force and the torque of a drilling rig. The diameter of pipes differs from 63 to 1200 mm. Material is low-pressure polyethylene, steel, cast iron.(2)

Horizontal directional drilling through the designed trajectory is possible due to location system. The drilling trajectory is limited by drilling angle (about 26-34%) and by rod bending radius. The allowable bending percent to one rod varies from 6 to 12% depends on the type of a rod.(3)

Horizontal directional drilling equipment and machinery are very diverse in the present time. The most famous producers are *Vermeer* (Figure 2.8), *Dith With*, *Tracto-Technik*, *Robbins*, *American Augers*, *Herrenknecht AG* and *Prime Drilling*. Lately a lot of producers from Korea and China appeared in the horizontal directional drilling market.(7)



Figure 2.8 The Vermeer drilling rig for HDD.

3 DIRECTIONAL DRILLING IN RUSSIA

3.1 The use of directional drilling in Russia

There is a lack of free space in megacities, especially in historical centers, which are very densely built. Underground territories are a large resource. In the nearest future underground cities will be created. Besides subway, engineering communications it is parking and transport tunnels, shopping malls and sport centers, storage of libraries and archives, multi storey interchange nodes with different services.

Russian Federation takes one of the first places in the world by the length of existing pipelines. More than half of them need renovation, because depreciation of pipelines is one of highest in the world.

The most perspective ways in trenchless technologies taken over from foreign colleagues for utilization in Russia are horizontal directional drilling, micro-tunneling, impact-mole, pipeline rehabilitation, auger drilling, etc.

Horizontal directional drilling (HDD) is one of the most rapidly developing trenchless pipe laying technologies. This technology gives an opportunity of crossing dams, wetlands, rivers and also other structures which have to stay intact during the laying of pipelines, cables or tunnels with small cross sections. Moreover, HDD technology minimizes the impact from a building process in densely built territories.(5)

Today the Russian market is overcrowded by organizations accomplishing HDD works. The main problem of this part of the market is high rates. As a result, dishonest companies are significantly dumping, although they could not accomplish the work in time with the right quality. But on the other hand high rates make the customer to make decision in favor of trench technologies. These methods break the everyday lifecycle of a city. In this way unreasonably high rates in fact ruin prospects of utilization of trenchless technologies in Russia. This problem is to be solved by creation of unified norms and rates based on existing normative documents on HDD.(7)

3.2 Pioneering in directional drilling

Before planning of constructional objects and trench communications pioneering is implemented in order to detect possible negative geo processes during a building exploitation. Pioneering is a complex research work on site of a future constructional object for making an objective design data or elimination of civil or constructional buildings.

Directional drilling is utilized for local soil research under construction in order to figure out the profitability of laying trench communications and organizing foundation in that area. Laying of communications is considered unacceptable in the following types of soil:

- sandy soil;
- clay;
- quicksand soils;
- gravel;
- loose sands etc. (4)

Monitoring is conducted not only before construction, but also during:

- elimination of object;
- reconstruction;
- retooling.

The features of pioneering are:

- analysis of the structure of soil profile;
- compatibility of the ground with following engineering structures;
- laboratory research of soil, its physical and mechanical structure;
- definition of probability of flooding, landslide and collapse on that area. (4)

Soil analysis is conducted (Figure 3.1).



Figure 3.1 Soil analysis.

Pioneering for construction is conducted by high-qualified specialists on contemporary equipment, which help to get precise information about soil conditions for construction. All the research must meet the Russian standards.

Types of research

All engineering works can be divided into economical and technical. The economical researches are preceded to the technical and implemented in order to figure out the profitability of a future constructional object on that area. (8)

Research is conducted for collecting of information about the geophysical view of soil conditions and cooperation between soil and planning constructional object.

In order to get full information complex pioneering is conducted, consisting of the following types of analysis:

- geological;
- geodetic;
- hydrometeorological;
- ecological.

Geological research studies the situation of cooperation between soil and the planned structure. The height of foundation and necessary strength of bearing elements are defined at this stage. Also soil properties and composition, and relief features are taken into account. Into the plan of events is also included an analysis of interaction of engineering objects with the environment and provision of ecological safety in that area. (4)

In *geodetic* area pioneering works accomplish in order to collect data about topography and relief features. Into the plan of events is also included making documentation of rationale for spending structural complexes or elimination of existing objects. At this stage a geodetic survey (Figure 3.2) is accomplished, which defines the place of the future constructional object. The results of a geodetic survey for project development is presented as a technical report in appliance with requirements of pp. 5.13 and 5.17 SNiP 11-02. (4)

Ecological tests are directed on exploration of ecological condition of the area and positive/negative condition for lifecycle, and also on minimization of damaging the environment. Ecological monitoring includes soil research, background radiation, sanitary and epidemiological tests, research of flora and fauna in this area etc. The data, collected by epidemiological tests, has a significant impact on the cost of construction. (4)

Also a groundwater research is included into a pioneering complex in order to define water supply sources or reasons of underflooding.

Steps of pioneering

Monitoring works take place in three steps:

- preparatory;
- field;
- cameral.

At the *preparatory* step collection of information about the object is produced. Also archival materials from previous pioneering are studied. (3) At this stage a

scope of research work and an action plan of situation assessment are formed. The dates of pioneering events are defined based on data collection.



Figure 3.2 Geodetic pioneering.

The field step includes geodetic, geological and topography pioneering and also aerial survey.

Here the cost of works depending on the scope and methods of research is defined. For the qualitative analysis it is necessary to make a plan of projects and calculations previously.

The *cameral* step sums up the research. At this stage topographic maps in necessary scale are composed, based on the received data. Prepared reports and documents further go through the state control, based on which the permission on construction is issued. (2)

Technical pioneering is produced by design and survey organizations. For the implementation of such scope of work special expeditions, groups and teams are organized.

So this paragraph shows that pioneering works are very important for the following exploitation of a constructional object. Better pay for the pioneering than for the recovery of collapsed structures later and more.

3.3 Directional drilling project

The directional drilling project is the optimal procedure in each environmental condition, even in extremely hard. By utilizing the directional drilling it is possible to lay engineering communications through the forestry, reservoirs, tracks and railroads. (7)

Moreover drilling, utilizing the projects of directional drilling with special equipment takes less time, than alternative methods of drilling. After such works the recovery of landscape or infrastructure is not required. This fact also impacts on the cost of drilling. (7) Directional drilling is much cheaper, than traditional excavation method of laying engineering pipelines.

One of the important design parts is preliminary research. Specialists collect documentation to create a protocol and a routing. Then soil composition and parameters analysis is accomplished, and the place of existing communication is assessed. (4)

Program 'Drill Site'

The directional drilling project can be created in different programs, which make designer work easier and let draw quality profiles of directional drilling. One of the famous programs, which are common on Russian market is a 'Drill Site' (Figure 3.3). It considers technological possibilities for implementation of works, landscape conditions and other niceties, which form a directional drilling project. (7)

The program requires a few minutes to create a profile and plan of drilling track. Drill Site is completely compatible with AutoCAD and files can be saved in DXF

format. So each file can be exported from one program to another and backwards.

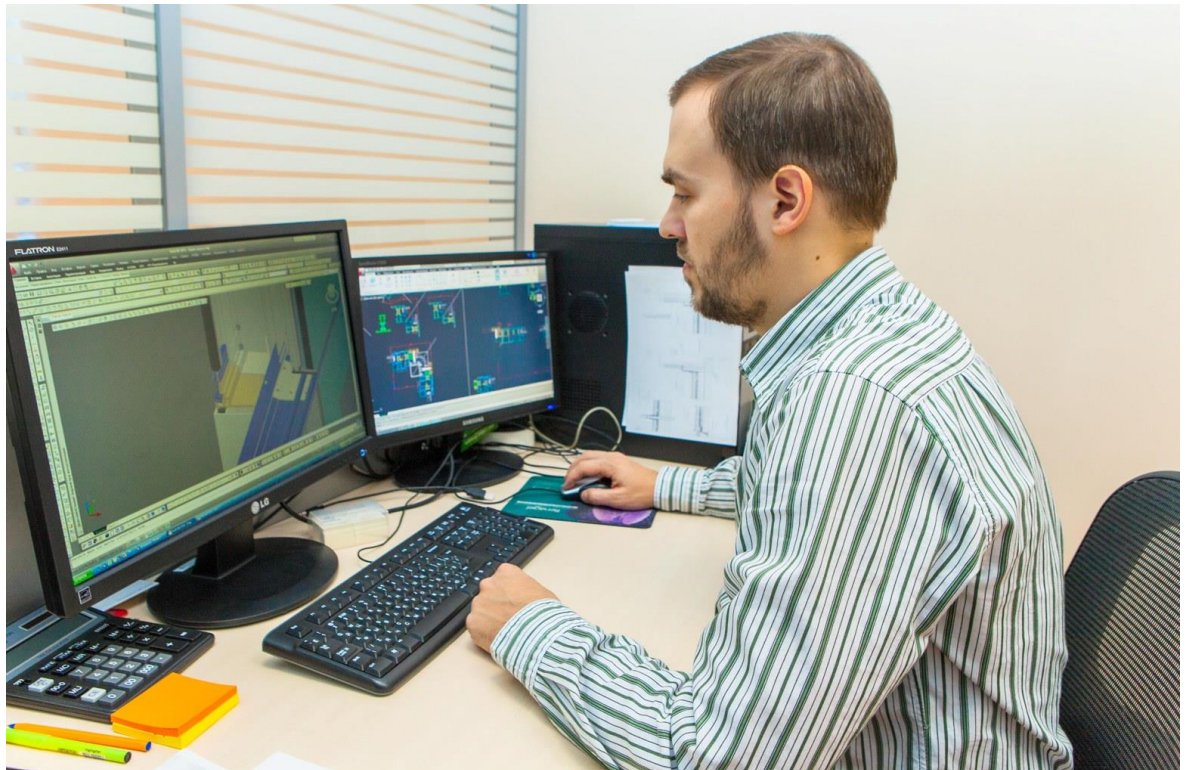

Figure 3.3 Designing in 'DRILL SITE'.

If 'Drill Site' is used for the creation of projects, the huge amount of time will be saved compared to handwork process. The design of directional drilling projects with program 'Drill Site' opens an access to a huge amount of special possibilities. Besides time and forces economy it is:

- professional methods for calculations of drilling track sizes;
- recommendations for pulling force, volume and compositions of materials;
- overlay of drilling plan by import files from AutoCAD;
- drawing any types of objects and communications in project;
- scaling of designed tracks;
- flexible control of all operational features of the landscape.(7)

The right and responsible approach gives many advantages. At first, during planning, problems related to random damages of the existing communication pipelines and also any dangerous situations can be avoided. The second,

correctly composed documentation and directional drilling project promote the staff to get to work more quickly without any unexpected delays and stops.

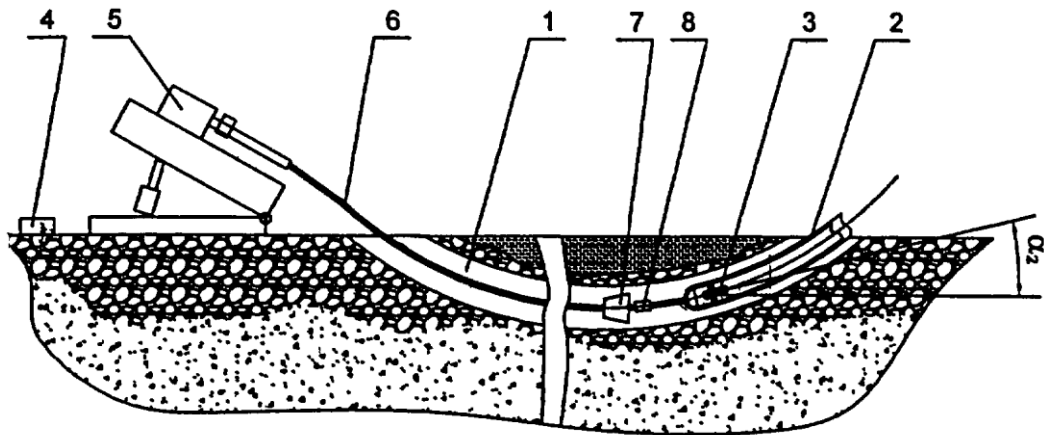

Фиг. 1

Figure 3.4 directional drilling project.

It is hard to find a directional drilling project and possible only during negotiation with designers, and workers, who implemented such works. During design process appear many features which can be recognized only with experience. An example, when making a plan the place of communication laid earlier must be considered. However, professionals recommend to order a gap more than 200 mm to pipes, even norms contain such distance. (7) On practice it is made in order to avoid any accidents.

It is necessary to compose a directional drilling profile (Figure 3.5) before the start of works, which will show topography, possible ground layers, groundwater and different communications. The drawing (Figure 3.4) allows calculating expected obstacles on the way of directional drilling rig. Including those it is necessary to address to constructional norms and rules named 'SNiP GNB' in Russia. (7) Such an approach will help not only to accomplish the work fast and qualitatively but also to avoid any problems with state controls departments.

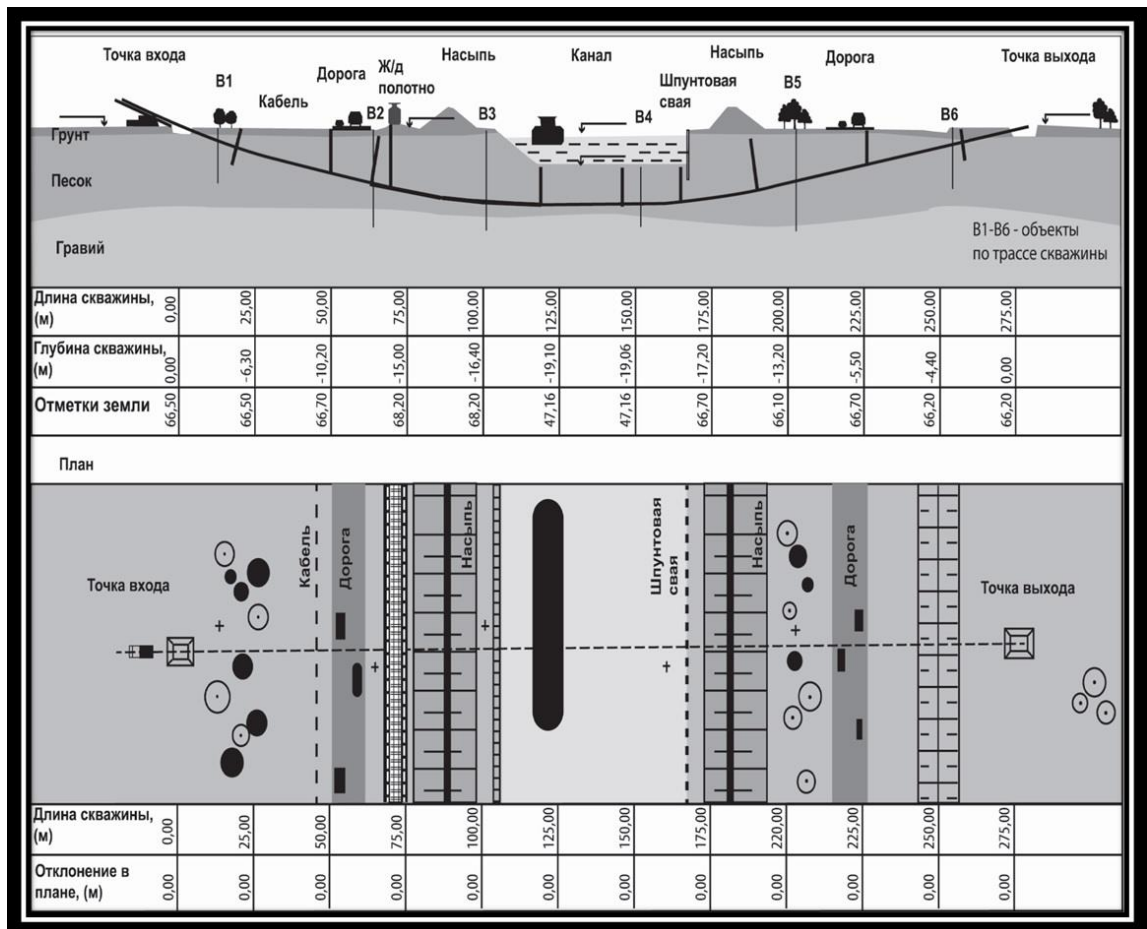

Figure 3.5 Directional drilling profile.

Also requirements from the customer must be considered. It is necessary to familiarize with all conditions and plans of the project before start. Then a geotechnical report must be overlooked. This gives an opportunity to define before the start of preparation the possibility of project implementation, the possibility of keeping within budget and dates, to recognize if the granted data is enough and are the all permissions recieved. This way will also help to cut down expenses.(7)

It is desirable to find an example of executive documentation in directional drilling in order to reduce time expenses and avoid delays and problems.

Then it is necessary to accomplish calculations and add to the project. The amount of drilling liquid must be calculated for estimators. One of the important stages in work is the right choice of directional drilling rig (Figure 3.6). It is necessary to choose a model with suitable maximum drilling length and bending radius, winch force. And also the model diameter must be fit. (1)

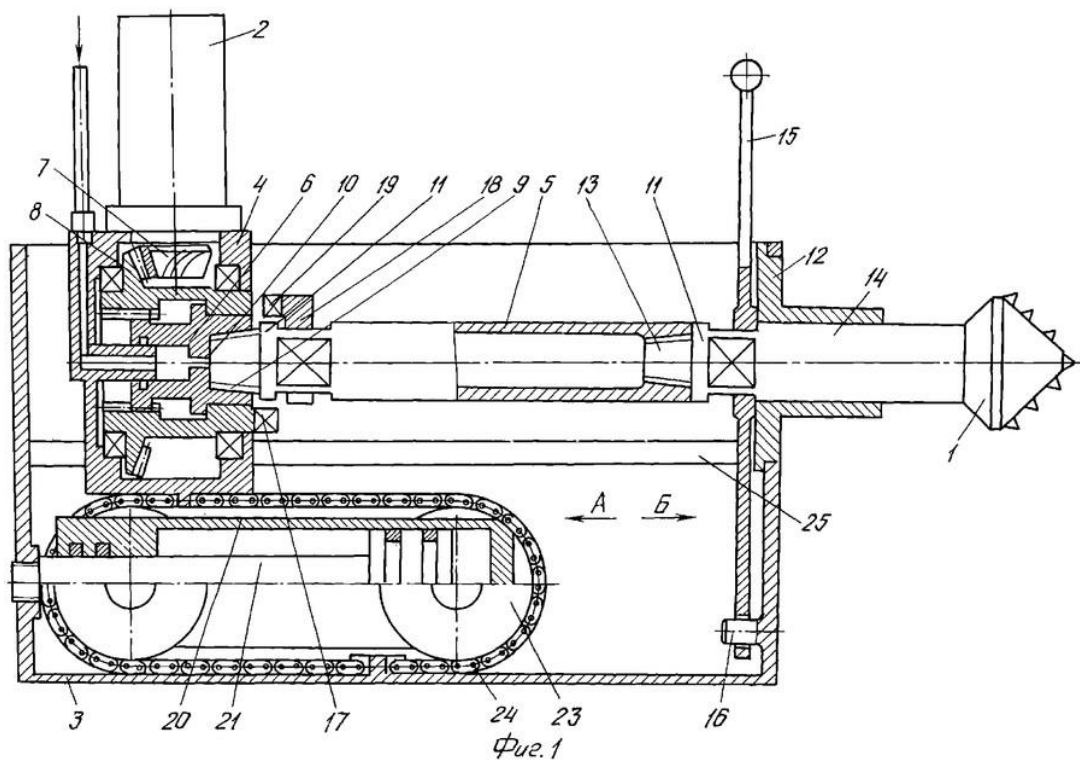

Figure 3.6 Directional drilling rig.

3.4 Russian approach to the directional drilling

Directional drilling process is divided into five stages:

The first stage is **preparatory**.

Before starting producing of works by directional drilling contractors are getting written work permissions according to the existing rules. Elaboration of the actual location of axes and occurrence depth of existing communications are produced before starting. The elaborated location of axes is fixed on site by markings for the whole time producing of works by directional drilling. (8)

The choice of track, laying by directional drilling, is produced together with representatives of a customer (prime contractor) considering local conditions. The chosen track is fixed on site by markings.(2)

A flat site dimensions are 10x15 m for a placement of a drilling complex and additional machinery is prepared. Preparing of driveways for directional drilling equipment delivery is produced if necessary.

Unloading of the directional drilling rig can be accomplished outside the site in a comfortable place followed by moving to the work place by its own motion a distance of 1 kilometer. The fencing of a building site of directional drilling is accomplished by a signal tape, placed on a height of 0.8 m from the ground and must exclude getting outsiders to the drilling zone. A directional drilling rig work zone lighting is provided by regular fixtures.(2)

The directional drilling complex deployment is produced on a prepared site. At the same time the drilling rig is placed at a well entry point and got to the working position. A longitudinal axis of a track-mounted drill is placed into a superposition with well target. And force anchoring of a bearing plate on the surface is produced by staff screws. A necessary angle of entry well is achieved by control of jib and back stabilizers of the directional drilling rig. The bentonite mortar preparation plant is placed next to the directional drilling rig in a distance of 10 meters. (1) The supply of necessary amount of drilling rods and bentonite mortar is implemented. The drilling rods are placed on timber linings on the right of the directional drilling rig on a distance of 2 meters from cassette loader. A stock of bentonite is placed near the bentonite mortar preparation plant into a container space or covered by roof.

Water supply for the preparation of the drilling mortar is accomplished by vehicles. The water stock can be created in volumetric capacity placed near the bentonite mortar preparation plant in order to provide continuous process of the directional drilling.(3)

There is a continuous two-way communication organized between the directional drilling rig operator and the directional drilling performance manager. Telemetry data transition of a position system from a moving block to a remote controller of the directional drilling rig is provided by a regular channel of a system. Communication between the performance manager and the representatives of a customer is provided by cellular.(8)

The second stage is ***pilot well drilling***.

The directional drilling rig is set in the chosen start point of a cable route. At first pilot well with the diameter of about 100 mm is drilled. The pilot well drilling process (Figure 3.7) is constantly controlled from the ground level through a location system, determining the location of the drilling head and its depth refers to the ground at any time.(1)

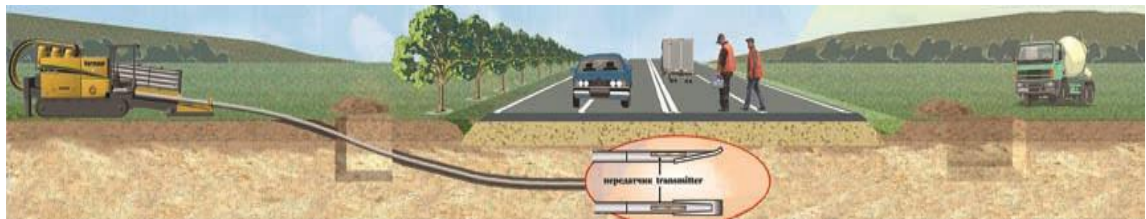

Figure 3.7 Pilot well drilling.

This system determines at present the following parameters: planned and high-rise position of the leading drill of the rig with precision of 10 cm; longitudinal and transverse angles of inclination of the leading drill; signal level; emitter temperature. This data is transmitted to an operator of the position system, placed above the leading drill and to an operator of the DD plant, allowing to lead the control of DD process and to correct its direction according to the design path.(8)

The drilling begins at angles from 10 to 20 to the horizon.(1) And it decreases as the drill comes to a necessary depth controlled by directional drilling rig and on the specified depth the drill keeps moving in horizontal direction and has an opportunity to correct a trajectory in any planes.

Definition of drill location is produced every three meters of well trajectory. Coordinates of points of actual well trajectory are logged and fixed on the site. If inclination of actual well trajectory of directional drilling is registered, then correction of drilling direction is produced and the inclination from design trajectory less than 0,5 meters at vertical direction and less than 1 m in horizontal is provided at the same time. (3)

As the drill approaches to the exit point, the well trajectory is heading up gradually and exits to the ground in the specified point at the design angle. This is the end of pilot well drilling.

The third stage is ***pilot well expansion***.

At the next stage, pilot well expansion (Figure 3.8) to the necessary diameter is produced. Also a reamer is installed instead of drilling head and it is extended backward from the exit point to the DD plant.



Figure 3.8 Pilot well expansion.

Extension can be accomplished by a single or several passes depending on soil conditions and the necessary well diameter. In the last case extension of several reamers is produced consequently with increasing of diameter.(8)

The fourth stage is ***laying of a pipeline***.

A previously prepared bundle of pipes is joined to the last reamer by a system of brackets and swivels and it is extended through the well (Figure 3.9). A conductor, which helps to protract a cable, is introduced into pipes before the extension.(2)

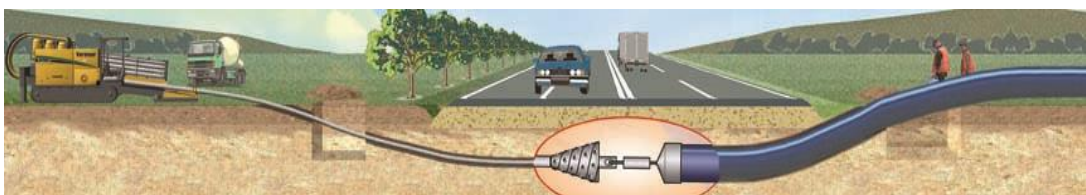

Figure 3.9 Laying of the pipeline.

Also the pipes are fixed to the end of drilling bundle by a special tip through the swivel. The tightening force is transmitted through the drilling bundle from the

drilling plant. The pipe is disconnected from the drilling bundle after extension and directional drilling process is considered completed.

The fifth stage is ***the end of the directional drilling works.***

Evacuation of a directional drilling complex is produced in reverse order to deployment with utilizing the same sidings. The directional drilling building site is subjected to cleaning: garbage and wastes are exported to landfill. The fencing and lighting of the site dismantles.(7)

The results of directional drilling works are sent to the representatives of the customer or to a commission assigned by order with drafting of an according deep.

The set of executive documentation is transmitted to the customer. The content of the set of the executive documentation and a number of examples is defined by the customer in accordance with the existing regulations.

Bentonite

The bentonite mortar is continuously supplied to the well under the pressure during the drilling process. It decreases friction, strengthens the borehole walls and supplants the drilled soil outside the well. The surpluses of bentonite mortar are collected in pits near the points of enter and exit. And then they are evacuated for recycling. (7)

Bentonite is white fine grained natural clay with certain options. Bentonite does not contain a toxic substances and it is environmentally friendly.

3.5 Quality control

When laying pipelines by directional drilling method all types of manufacturing inspections, mentioned in 'SP 48.13330 – input, operational and acceptance inspections' must be done. At the stage of the incoming inspection the quality of products and materials coming to a site are checked. The operational control

ensures the implementation of drilling and building works quality. The acceptance inspection ensures the quality and conformity of the laid pipeline to a design project. The results of inspections must be secured in the working logs, in the acts on the hidden works, in the incoming acts and in the other documents. (4)

The design organization must accomplish an author's supervision for the implementation of technical decisions and requirements applied to the project production. Also the designer must accomplish a correction or agreement of grounded changes in the project if necessary.(7)

3.6 Cost estimation

One of the important parts is the cost of the directional drilling project. The actual average on Russian directional drilling market is shown in the table below.

Table 3.1 Relation between price and diameter of the pipe

HDPE outer diameter of the pipe (mm)	the average price meter depression (e/mtr)
63 MM	from 1800 to 2100 rubles
110 MM	from 2200 to 3000 rubles
160 MM	from 2500 to 3800 rubles
225 MM	from 3900 to 5500 rubles
315 MM	from 7000 to 9500 rubles
400 MM	from 9000 to 12500 rubles
500 MM	from 11000 to 14500 rubles
600 MM	from 14000 to 16500 rubles
700 MM	from 17500 to 24000 rubles
800 MM	from 22000 to 28000 rubles

Important! The costs shown in the table are without ground works.

The costs given in the table can change depending on the length of closed transition, amount of pipes into a bundle, pipe material and placing of the object.(4)

Price formation

The main factors of cost formation in directional drilling are the length of drilling transition and diameter of laying pipes. The more pipes in one bundle is laid, the less the cost of laying is. The maximum number of pipes with 110 mm diameter in one bundle is 26; with diameter 160 mm in one bundle is 14, with diameter 225 mm is 8. Preparatory works on each site take about 40-50% from the whole time of works. Due to optimal combination of all types of expenses and reducing of costs at each stage of construction the final price of directional drilling becomes the most profitable with the optimal value for money.(7)

Market prices of directional drilling can differ significantly from company to company, depending on size of direct point of cost, level of performance organization, level of staff knowledge. In order to get the lowest price in directional drilling the company should follow the following points:

- direct cooperation with factories of building materials;
- purchasing drilling liquids by the wholesale prices;
- precise engineering preparation of the site;
- geological analysis, optimal drilling liquid selection;
- well-oiled drilling process, professional staff;
- keeping the equipment in good conditions and under supervision, timely repair.(7)

3.7 Work Safety on drilling site

- The producing of work must be implemented according to a number of regulatory documents: 'SP 49.13330', 'SNiP 12-04-2002', 'SP 40-102-2000'[15], 'SanPin 2.2.3.1384-03' [67] and other documents.
- It is necessary to ensure reliable and stable two-sided communication between the sites on the side of drilling rig working (input point) and on the side of assembling of a pipeline (output point).

- The drilling mortar flowed out from a well must be directed to special pits or collectors; line of washing water must be conducted to the drilling place.
- During the work process the whole principal staff is equipped with safety antidust filtering masks and protective glasses.
- Damage of underground constructions as a result of drilling works can cause an explosion, fire, injuries from electricity or poisonings with toxic substances. The following refers to the sources of danger:
 - power lines;
 - gas pipelines;
 - fiber optic cables;
 - sewer pipelines;
 - pipelines for transmitting liquid or gaseous chemical substances;
 - underground storage tanks.(2)

4 THE ACTIVITY AND DEVELOPMENT OF RUSSIAN SOCIETY FOR TRENCHLESS TECHNOLOGIES

RSTT was established in 1996 as a subdivision of the Tunnel association of Russia. During the years from 1996 to 2012 RSTT announces itself to the world by entering to the International Society for Trenchless Technology (ISTT). RSTT promotes to the development of trenchless technologies by organizing study for the manufacturing staff, by holding seminars, by taking part in different professional exhibitions, etc. However, the number of RSTT members did not increase. There were no major discoveries, and the main problems were staying unsolved.(7)

The work of the Committee covers almost all questions, related to underground space exploration. And one of the most important directions is engineering communications laying using trenchless technologies. Much has been done in the field of technical regulation during the end of the last year. However, the complex decision of the problems can only be achieved in a dialogue of the

professional society with profile state departments. Another topic is the prospects of international cooperation. Participants of this event familiarized with the content of agreement between RSTT and Tunnel association of Finland and approved an idea of participation in annual National conference of Finnish Society for Trenchless Technologies in the city of Lahti.

Nowadays RSTT includes special organizations from different regions of Russia, which are actively implementing trenchless technologies, accomplishing major volumes of work in laying, recovering and repairing of pipelines on sites of oil, gas and electric power industries, laying links, water pipes, sewerage and engineering communications of cities. RSTT shares the goals and objectives of ISTT and tends to consolidate efforts of builders, designers and scientists for the popularization of trenchless building in terms of economy, reliability, ecological and historical safety of Russian cities.

One of the objectives of RSTT for the near future is a thorough knowledge of a foreign experience in trenchless technologies. The first trips to Finland and China appeared very informative. In Finland spectacular success in underground building area was achieved. There is a systematic study of soils. A publicly available information base about hydrogeology of soils has been created. There are large numbers of drilled wells. Almost all underground works are accomplished by trenchless methods.(7)

There is a quite similar situation in China. About 10 years ago Russia and China were approximately in the same conditions. But now China is much ahead in trenchless technology development in comparison with Russia. There are some engineering factories, releasing equipment for the underground building. Nowadays Chinese equipment takes a third of the Russian market. At the same time Russia purchases machinery, equipment, tools and even clay for drilling fluids at international market. Professional training in Russia is led only by company themselves. Companies create their own courses, hire teachers and control the studies. Furthermore, it is necessary to create a scientific foundation for this building area.(7)

RSTT has actively joined to the development of the normative base for underground building in Russia. There is a necessity in correcting of many federal laws - Town-planning and Land codes of Russia, etc. Very important problem is pricing. The company, which offers the cheapest services, gets the tender. Creation of industry-wide basis lags behind.

For the last year on the initiative of the National builders association of Russia a number of documents was made, regulating activity in underground building area. International set of rules 'Underground engineering communications lay by Horizontal Directional Drilling' is developed. 'Standards and recommendations of National Builders Association in micro-tunneling' and a number of other normative documents were made, which will solve many questions. On the basis of the received data registries of reliable companies in the underground construction area must be formed. It is important that they must have an official status and are utilized in the choice of contractor to implementation of different kind of works. The registry holder must organize professional associations, work for the committee of Russian trenchless technology. The role of special associations in Russia must be increased.(7)

In 2013 RSTT elected a new president and marked a number of objectives to solve firstly. In accordance with these objectives RSTT must improve regulatory control, amend legislative acts and start to prepare specialists in trenchless technology. The next very important step is a formation of certification authority enterprises in trenchless technology area. RSTT was appointed as a coordinator of trenchless technologies in Russia. The new RSTT president organized signing an agreement of information interchange and cooperation between RSTT, FISTT and ISTT.(5)

There are also some questions, requiring attention of professional community: stop passing to the market non-qualified companies, organization of preparing working specialties, ensuring information change between specialists etc. It is necessary to initiate an interaction of all participants of market for the successful decision of assigned tasks, so the RSTT leadership urges to join to the professional community. It is impossible to achieved the desirable results without interest and support of RSTT members.

In order to study the international experience in area of creation technical conditions and technological laying of engineering communications with applying of directional drilling a request was made to international communities with petition to provide regulatory documents, acting in European Union.

In 2014 at the meeting of RSTT, Finnish Tunnel Association and FISTT the latter provided texts of Finnish national applications to the European normative documents. The President of International association of specialists in horizontal directional drilling noted that in spite of wide application of directional drilling the technology was still not legalized in normative documents in Russia. The set of rules is developed first. The next stage will be the creation of documents in pricing area. (7)

5 FINNISH APPROACH TO THE DIRECTIONAL DRILLING

The directional drilling is quite a new technology in Finland. Conventional excavation and cable ploughing are the most common ways of laying pipelines. Directional drilling opens new opportunities for the development of underground structures because it keeps the ground surface untouched during the drilling stages, unlike the traditional methods, but drilling is controlled from the ground.(5)

Directional drilling technology provides cost-effective results in the laying of underground pipelines and cables. The remote controlled directional drilling is also an environmentally friendly method of installation.

In addition, directional drilling has brought a new market sector, for Finnish companies and the use of new methods has begun to raise its head instead of traditional methods. New alternative methods for installing underground structures develop competition of the techniques, and also make the techniques more modern and more environmentally friendly. (6)

In Finland, there is no specific training in the use of trenchless technology equipment, but entrepreneurs usually train their employees themselves. Experienced contractors in Finland shortfall the most extensive know-how in the

methods used. Importers and manufacturers of equipment can organize training sessions for customers and equipment demonstrations. (6)

Employees must have the necessary valid security cards, such as road safety, rail safety certificate. In addition, employees have a valid water work card allowing working with the water supply pipes, as well as any other qualifying work training, such as plastic welding or other qualifications. The company must have a documented installers training plan and training should give sufficient information on the methods, materials and safety issues, access to the other construction equipment at the site, such as trucks and excavators, the existing professional criteria, which is available for training.(6)

In Russia, particularly in Saint-Petersburg there is a very strong school of subway building and Finnish subway builders invite the colleagues from Saint-Petersburg.

Due to administrative policy at the territory of Finland there are so many raising projects of underground area development, that Finnish specialists are almost completely focused on the internal market. Now the Finnish companies are ready for the partnership with the Russian side only on advisory basis. (6)

At the legislation point of view Finland has less number of barriers than Russia. Finnish colleagues quite effectively decide investing questions. For example underground coal storage for heating station is built on budget, received from organizations which purchased office centers in previous place.

So Finland has a lot of projects of underground building so it can completely focused on internal market and even invite international specialists to join the underground development of the country. Finland has a large space for trenchless technology development so this fact gives a reason to think that this country will be rapidly moving to the top of international trenchless technologies motion.(6)

5.2 Work safety on drilling site

According to Occupational Safety and Health Act (738/2002) section 14 (instruction and guidance to be provided for employees) “Employers shall give their employees necessary information on the hazards and risk factors of the workplace and ensure, taking the employees’ occupational skills and work experience into consideration, that:

- (1) the employees receive an adequate orientation to the work, working conditions at the workplace, working and production methods, work equipment used in the work and the correct method of using it, as well as to safe working practices, especially before the beginning of a new job or task or a change in the work tasks, and before the introduction of new work equipment and new working or production methods;
- (2) the employees are given instruction and guidance in order to eliminate the hazards and risks of the work and to avoid any hazard or risk from the work jeopardising safety and health;
- (3) the employees are given instruction and guidance for adjustment, cleaning, maintenance and repair work as well as for disturbances and exceptional situations; and
- (4) the instruction and guidance given to the employees is complemented, when necessary.” (6)

5.3 Cost estimation

The actual average prices are shown in the table below.

Prices include drilling one meter, transport equipment and pipe materials. The table was taken from Rapal brochure.

Table 5.1 Average prices for table meter installed in horizontal directional PEH-pipes

HDPE outer diameter of the pipe (mm)	the average price meter depression (e/mtr)
168,3	235,87
219,1	279,8
273,0	337,27
323,9	402,17
406,4	509,65
508,4	924,73
610,0	1346,14
711,0	1995,83
1018,0	2839,18
1220,0	3396,23

Before drilling the drilling fluid used must be assessed, so that the drilling fluid can not run out while drilling. Drilling fluid usually takes 1-5 times(6)

6 COMPARISON OF FINNISH AND RUSSIAN APPROACHES

It is hard to compare the approaches of these countries, because Russia has just stood up the way of trenchless technologies development. But it is possible to say that the rapid development of FISTT and all Finnish underground communities, which take significant parts in that development lead Russia the way. The union of FISTT and RSTT as official representatives of their countries just confirmed this point of view.

So it would be right to say that Russia learns the Finnish approach of directional drilling and the whole trenchless technologies. In that way all parts like safety of the drilling process and drilling stages are relatively the same.

7 CONCLUSION

In the end all the facts should be summarized. At first all advantages of directional drilling must be shown.

So the directional drilling technologies allowed:

- to dramatically increase the pace of work in building and renovation of worn out communications, to utilize financial and material resources much effectively;
- to follow ecological norms, to almost exclude leading large-scale ground works, to eliminate a threat of ground water level increasing and pollution of soil arrays by household and manufacturing drains;
- to ensure a non-stop transport motion in the district where works are produced;
- to decrease the direct and indirect financial and time expenses by almost a half.

The conventional excavation gives a way to the trenchless technologies gradually. It is the contemporary flow in infrastructure development. According all facts mentioned in my thesis the trenchless technologies totally follow the principles of green construction. Nowadays large attention is paid to the development of green construction. Opened communication pipe laying also is

forbidden in the centers of a large number of cities. This gives a powerful pulse to the development of trenchless technologies and also to the directional drilling.

In my opinion Russia should connect to the international flow of directional drilling development. It also becomes one of the main parts of sustainable development of progressive countries and we should apply the rules of this game and start to develop this method rapidly.

In the nearest future we should solve the following problems:

- let the professional of the underground construction to lead the Russian trenchless technology;
- it is necessary to develop contemporary regulatory documents;
- very important to solve the pricing questions. Without reasonable prices the development of this sector is impossible;
- we have almost no own equipment as for directional drilling, as for micro-tunneling, as for rehabilitation of pipelines in Russia. It is necessary to promote domestic producing of equipment and other materials for the trenchless technologies;
- there is no preparation of specialists in trenchless technologies area in any Russian University. It is planned to change this situation radically and develop suitable programs, invite international specialists for reading lectures, found grants and organize a preparation of professionals for companies with prospect;
- It is also necessary to cover the events and development of trenchless technologies in mass media in order to attract more people in it;
- there is a need in development of domestic scientific side of trenchless technologies;
- required to organize a council of experts to give the opinion of the admission to implementation of directional drilling works.

FIGURES

- Figure 2.1 The head of impact moling rig, p.6.
- Figure 2.2 The principal scheme of impact moling process, p.7.
- Figure 2.3 The auger boring stages, p.8.
- Figure 2.4 The pipe ramming machine, p.9.
- Figure 2.5 The pipe ramming process in action, p.10.
- Figure 2.6 The preparation for pipe ramming, p.11.
- Figure 2.7 Horizontal directional drilling under water obstacle, p.11.
- Figure 2.8 The Vermeer drilling rig for HDD, p.12.
- Figure 3.1 Soil analysis, p.15.
- Figure 3.2 Geodetic pioneering, p.17.
- Figure 3.3 Designing in 'DRILL SITE', p.19.
- Figure 3.4 directional drilling project, p.20.
- Figure 3.5 Directional drilling profile, p.21.
- Figure 3.6 Directional drilling rig, p.22.
- Figure 3.7 Pilot well drilling, p.24.
- Figure 3.8 Pilot well expansion, p.25.
- Figure 3.9 Laying of the pipeline, p.25.

TABLES

- Table 3.1 Relation between price and diameter of the pipe, p.27.
- Table 5.1 Average prices for table meter installed in horizontal directional PEH-pipes, p.35.

REFERENCES

1. Explanatory note to the Professional Standard Horizontal Directional drilling complex operator, Committee Report 2013, Moscow, Ministry of Construction.
2. SNiP 12-03-2001
3. SP 49.13330.2012
4. STO NOSTROY 2.27.17-2011
5. <http://www.istt.com/> accessed on 7 June 2016
6. <http://www.fistt.net/> accessed on 16 May 2016
7. <http://robt.ru/> accessed on 3 July 2016
8. The basis of trenchless technologies, A.P. Rybakov, 2005, Moscow.